



# Grid-tied PV String Inverter

SUN-12K-G03

SUN-15K-G03

## User Manual



---

# Contents

1. Introduction	- 01 -
1.1 Appearance Introduction	- 01 -
1.2 Parts list	- 02 -
2. Safety warnings and instructions	- 03 -
2.1 Safety signs	- 03 -
2.2 Safety instructions	- 03 -
2.3 Notes for using	- 04 -
3. Operation Interface	- 05 -
3.1 Interface View	- 05 -
3.2 Status Indicator	- 05 -
3.3 Buttons	- 06 -
3.4 LCD Display	- 06 -
4. Product installation	- 07 -
4.1 Select installation location	- 07 -
4.2 Inverter Installation	- 09 -
5. Electrical Connection	- 11 -
5.1 DC input terminal connection	- 11 -
5.2 AC input terminal connection	- 13 -
5.3 The connection of the ground line	- 16 -
5.4 Max. over current protection device	- 17 -
5.5 Inverter monitoring connection	- 17 -
5.6 Installation of Wi-Fi Plug	- 18 -
5.7 Configuration of Wi-Fi Plug	- 18 -
6. Startup and Shutdown	- 19 -
6.1 Start up the inverter	- 19 -
6.2 Inverter Shutdown	- 19 -
7. Zero export function via SUN limiter	- 20 -
7.1 SUN Limiter function wiring diagram	- 20 -
7.2 Connect the SUN limiter to inverter	- 21 -
7.3 Use of zero export function	- 23 -
7.4 Zero-export function (Option)	- 24 -
7.5 Notes while using zero export function	- 27 -
8. General Operation	- 28 -
8.1 The initial interface	- 28 -
8.2 Submenus in the Main Menu	- 29 -
8.3 System param setting	- 32 -
8.4 Running param set	- 32 -
8.5 Protect Param	- 34 -
8.6 Com. param set	- 35 -
9. Repair and Maintenance	- 35 -
10. Error information and processing	- 35 -
10.1 Error code	- 36 -
11. Specification	- 39 -

# Photovoltaic Grid-connected System

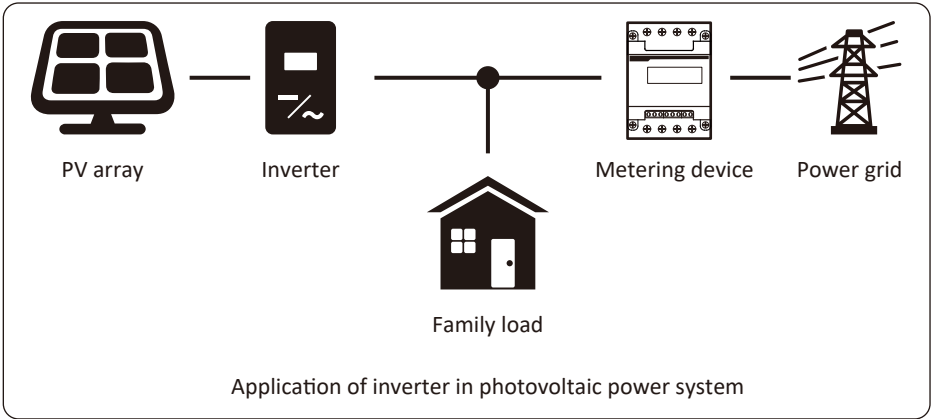

## 1. Introduction

### 1.1 Appearance Introduction

On-grid inverter can convert solar panel DC power into AC power which can directly input to the grid. Its appearance is shown below. These models contain SUN-12K-G03、SUN-15K-G03、SUN-18K-G03.

The following is collectively referred to as 'inverter'.

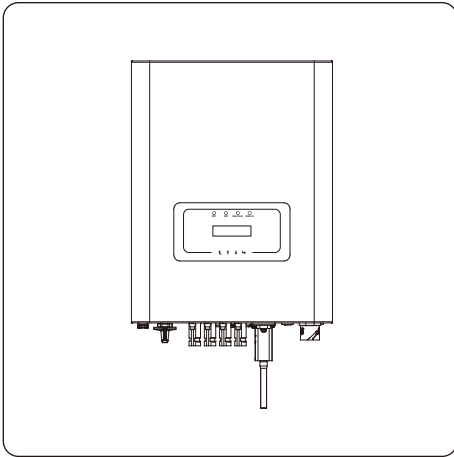

Pic 1.1 Front view

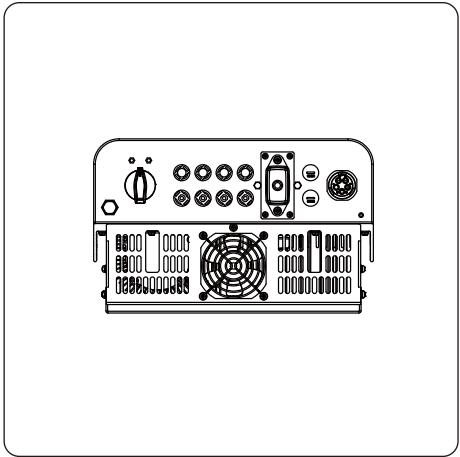

Pic 1.2 Bottom view

## 1.2 Parts list

Please check the following table, to see whether all the parts are included in the package :

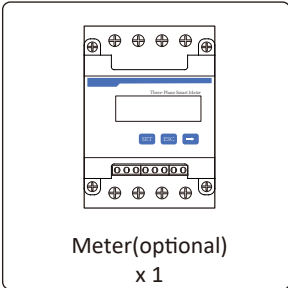
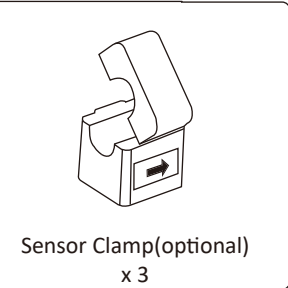
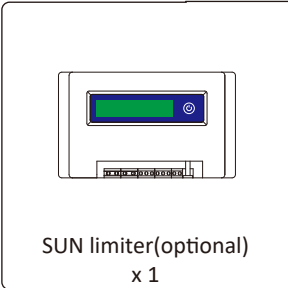
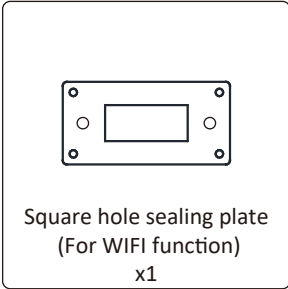
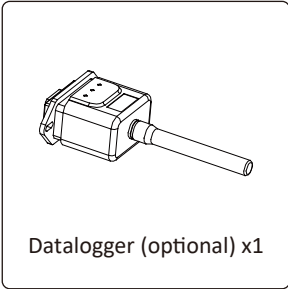
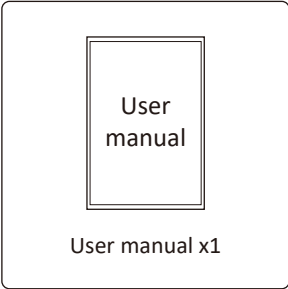
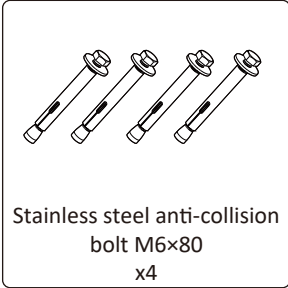
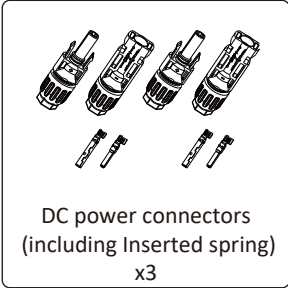
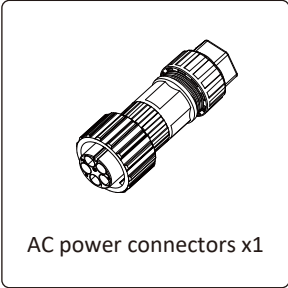
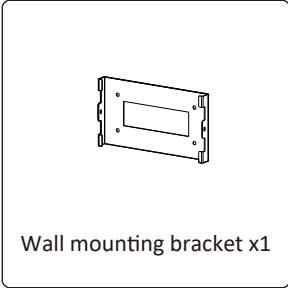
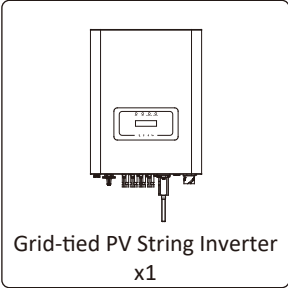

## 2. Safety warnings and instructions

Improper use may result in potential electric shock hazards or burns. This manual contains important instructions that should be followed during installation and maintenance. Please read these instructions carefully before use and keep them for future reference.

### 2.1 Safety Symbols

Safety symbols used in this manual, which highlight potential safety risks and important safety information, are listed as follows:



**Warning:**

Warning symbol indicates important safety instructions, which if not correctly followed, could result in serious injury or death.



**Shock Hazard:**

Caution, risk of electric shock symbol indicates important safety instructions, which if not correctly followed, could result in electric shock.



**Safety Hint:**

Note symbol indicates important safety instructions, which if not correctly followed, could result in some damage or the destruction of the inverter.



**High Temperature Hazard:**

Caution, hot surface symbol indicates safety instructions, which if not correctly followed, could result in burns.

### 2.2 Safety instructions



**Warning:**

Electrical installation of the inverter must conform to the safety operation rules of the country or local area.



**Warning:**

Inverter adopts non-isolated topology structure, hence must insure DC input and AC output are electrical isolated before operating the inverter. Strictly prohibit grounding the positive and negative poles of the PV string. Otherwise it will damage the inverter.



**Shock Hazard:**

Prohibit disassembling inverter case, there existing shock hazard, which may cause serious injury or death, please ask qualified person to repair.



***Shock Hazard:***

When PV module is exposed to sunlight, the output will generate DC voltage. Prohibit touching to avoid shock hazard.



***Shock Hazard:***

While disconnect the input and output of the inverter for maintenance, please waits for at least 5 mins until the inverter discharge the remnant electricity.



***High Temperature Hazard:***

Local temperature of inverter may exceed 80°C while under operating. Please do not touch the inverter case.

### 2.3 Notes for using

The three phase string power inverter is designed and tested under related safety regulations. It can ensure the personal safety of the user. But as a electric device, it may cause shock or injury by incorrect operation. Please operate the unit under below requirements:

1. Inverter should be installed and maintained by qualified person under local standard regulations.
2. Must disconnect the AC side first, then disconnect DC side while doing installation and maintenance, after that, please wait at least 5 mins to avoid getting shocked.
3. Local temperature of the inverter may exceed 60 °C while under operating. Do not touch to avoid getting injured.
4. All electrical installation must be in accord with local electrical standards, and after obtaining the permission of the local power supply department, the professionals can connect the inverter to the grid.
5. Please take appropriate anti-static measure.
6. Please install where children can not touch.
7. When starting the inverters, first close the circuit breaker at the grid side, then close the DC side; when closing the inverters, first disconnect the circuit breaker at the AC side, then disconnect the DC side.
8. Don't insert or remove AC and DC terminals when the inverter is in normal operation.
9. The DC input voltage of the inverter must not exceed the maximum value of the model.

### 3. Operation Interface

#### 3.1 Interface View

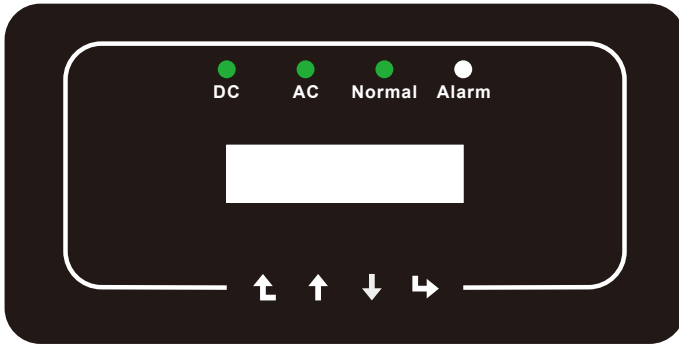

Pic 3.1 Front panel display

#### 3.2 Status Indicator

There are four LED status indicator lights in the front panel of the inverter. Please see table 3.1 for details.

<b>Indicator</b>	<b>status</b>	<b>Explanation</b>
● DC	on	Inverter detects DC input
	off	Low DC input voltage
● AC	on	Grid Connected
	off	Grid Unavailable
● NORMAL	on	Under normal operating
	off	Stop operating
● ALARM	on	Detected faults or report faults
	off	Under normal operating

Table 3.1 Status indicator lights

---

### 3.3 Buttons

There are four keys in the front panel of the Inverter(from left to right): Esc, Up, Down and Enter keys. The keypad is used for:

- Scrolling through the displayed options (the Up and Down keys);
- Access to modify the adjustable settings (the Esc and Enter keys).



### 3.4 LCD Display

The two-line Liquid Crystal Display (LCD) is located on the front panel of the Inverter, which shows the following information:

- Inverter operation status and data;
- Service messages for operator;
- Alarm messages and fault indications.



## 4. Product installation

### 4.1 Select installation location

To select a location for the inverter, the following criteria should be considered:

**WARNING: Risk of fire**

- Do not install the inverter in areas containing highly flammable materials or gases.
- Do not install the inverter in potentially explosive atmospheres.
- Do not install in small closed spaces where air can not circulate freely. To avoid overheating, always make sure the flow of air around the inverter is not blocked.
- Exposure to direct sunlight will increase the operational temperature of the inverter and may cause output power limiting. Deye recommends inverter installed to avoid direct sunlight or raining.
- To avoid overheating ambient air temperature must be considered when choosing the inverter installation location. Deye recommends using a sun shade minimizing direct sunlight when the ambient air temperature around the unit exceeds 100°F/40 C.

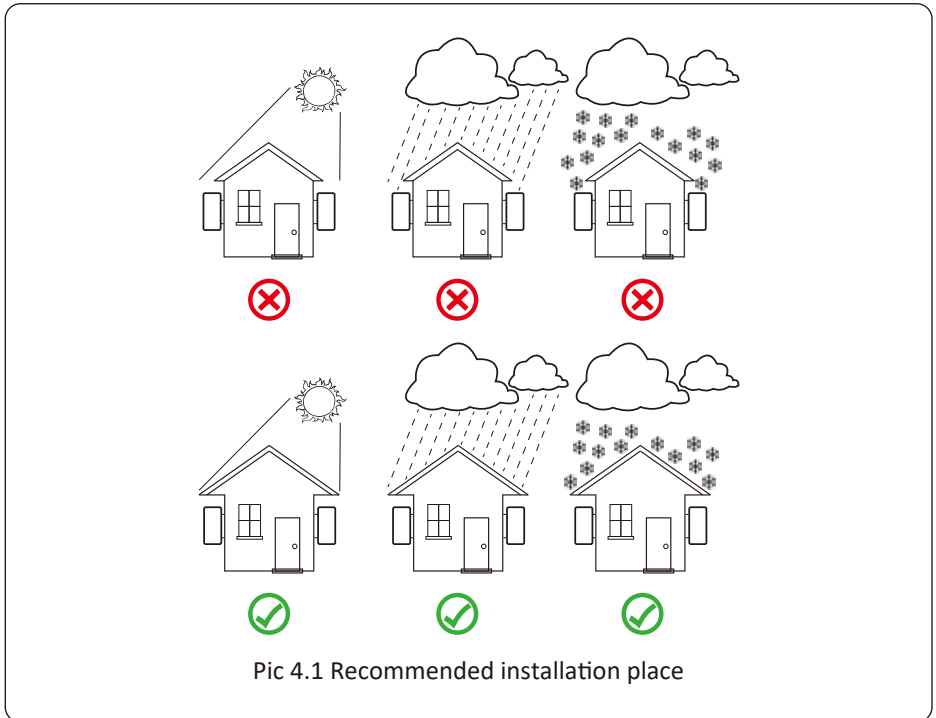

- Install on a wall or strong structure capable of bearing the weight.
- Install vertically with a maximum incline of  $\pm 15^\circ$ . If the mounted inverter is tilted to an angle greater than the maximum noted, heat dissipation can be inhibited, and may result in less than expected output power.
- If install more than one inverter, must leave at least 500mm gap between each inverter. And each inverter must be at least 500mm above and below. And must install the inverter at the place where children cannot touch. Please see picture 4.3.
- Consider whether the installation environment is helpful to see the inverter LCD display and indicator status clearly.
- Must offer a ventilate environment if inverter installed in the airtight house.



**Safety Hint:**

Do not place or store any items next to the inverter.

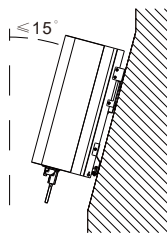
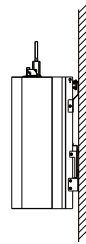
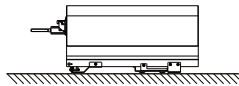
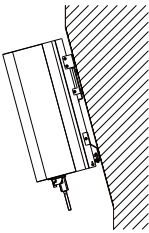

Pic 4.2 Installation Angle

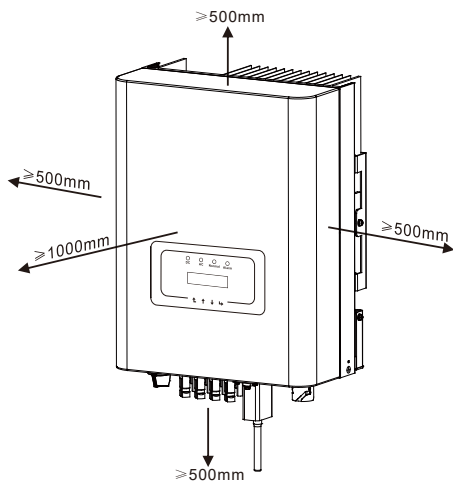

Pic 4.3 Installation Gap

#### 4.2 Inverter Installation

The inverter is designed according to the wall mounted type installation, please use the wall mounted (the brick wall of the expansion bolt) when installing.

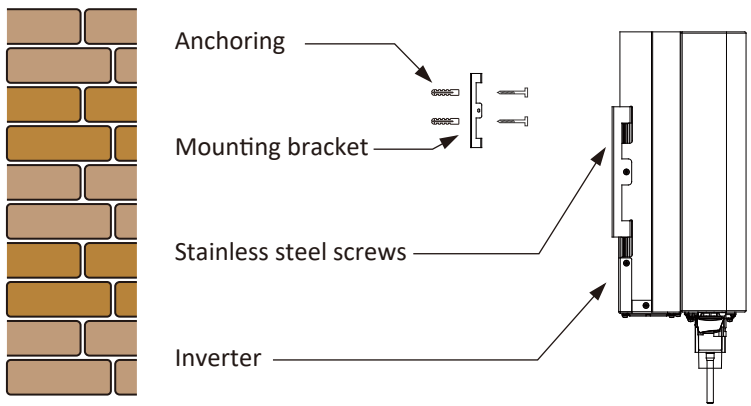

Pic 4.4 Inverter Installation

Procedure shows below:

1. Locate on the appropriate wall according to the bolt position on the mounting bracket, then mark the hole. On the brick wall, the installation must be suitable for the expansion bolt installation.

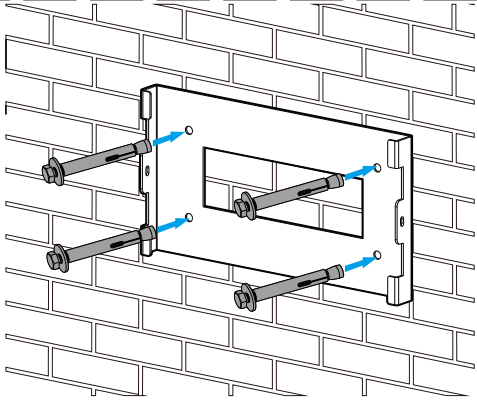

Pic 4.5 Inverter hanging plate installation

- 2. Ensure that the position of the installation holes on the wall is in accordance with the mounting plate, and the mounting rack is horizontally placed.
- 3. Hang the inverter to the top of the mounting rack and then use the M4 screw in the accessory to lock inverter heat sink to the hanging plate, to ensure that the inverter will not move.

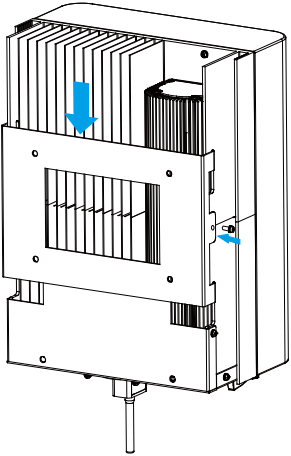

Pic 4.6 Inverter installation

## 5 Electrical Connection

### 5.1 DC input terminal connection

1. Switch the Grid Supply Main Switch(AC)OFF.
2. Switch the DC Isolator OFF.
3. Assemble PV input connector to the inverter.



**Safety Hint:**

Please don't connect PV array positive or negative pole to the ground, it could cause serious damages to the inverter.



**Safety Hint:**

Before connection, please make sure the polarity of the output voltage of PV array matches the "DC+" and "DC-" symbols.



**Safety Hint:**

Before connecting inverter, please make sure the PV array open circuit voltage is within the 1000V of the inverter.

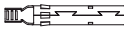

Pic 5.1 DC+connector (MC4)



Pic 5.2 DC-connector (MC4)



**Safety Hint:**

Please use approved DC cable for PV system.

Cable type	Cross section (mm <sup>2</sup> )	
	Range	Recommended value
Industry generic PV cable (model: PV1-F)	4.0~6.0 (12~10AWG)	4.0(12AWG)

Table 5.1 DC Cable Specifications

The steps to assemble the DC connectors are listed as follows:

a) Strip off the DC wire about 7mm, disassemble the connector cap nut (see picture 5.3).

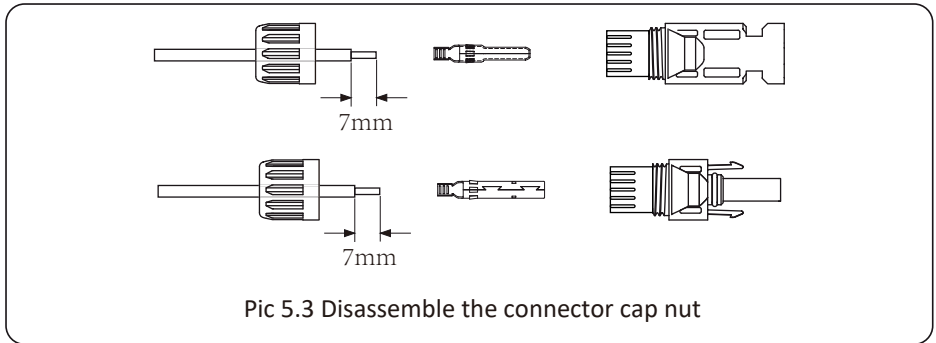

b) Crimping metal terminals with crimping pliers as shown in picture 5.4.

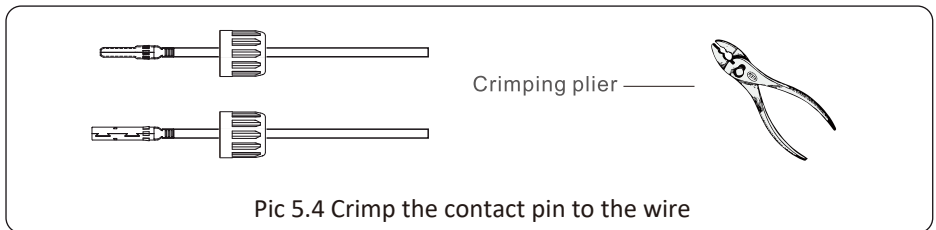

c) Insert the contact pin to the top part of the connector and screw up the cap nut to the top part of the connector. (as shown in picture 5.5).

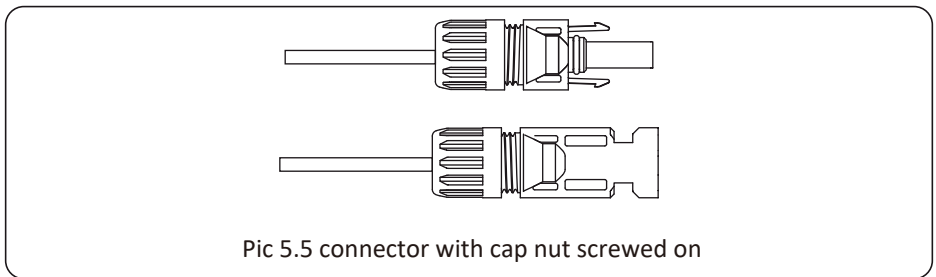

d) Finally insert the DC connector into the positive and negative input of the inverter, shown as picture 5.6

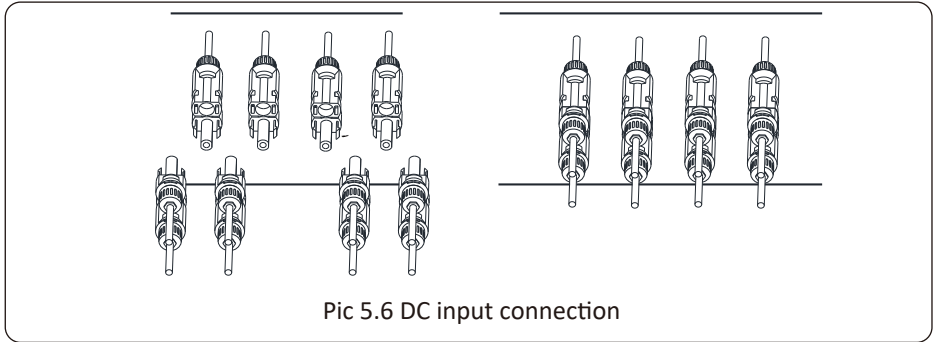

**Warning:**

Sunlight shines on the panel will generate voltage, high voltage in series may cause danger to life. Therefore, before connecting the DC input line, the solar panel needs to be blocked by the opaque material and the DC switch should be 'OFF', otherwise, the high voltage of the inverter may lead to life-threatening conditions.

**5.2 AC input terminal connection**

Do not close the DC switch after the DC terminal is connected. Connect the AC terminal to the AC side of the inverter, the AC side is equipped with Three phase AC terminals that can be conveniently connected. Flexible cords are recommended for easy installation. The specifications are as shown in Table 5.2.



**Warning:**

Prohibit using a single circuit breaker for multiple inverters, prohibit the connection of load between inverter circuit breakers.

Model	Cable CSA	Cable outer dia	AWG	Breaker	Max cable length
SUN-12K/15K-G03	6mm <sup>2</sup>	20-25mm	10	30A/400V	Outside cable (3+PE)20m

Table 5.2 Cable information

The AC output connector is divided into three parts: matching socket, sleeve and sealing-sleeve, as shown in picture 5.7, the steps are as follows:

- Step 1: Remove the cable sealing ring and sleeve in sequence from the AC connector.
- Step 2: Use strippers to strip the protective sheath and insulation layer of the AC cable to the right length, as shown in Picture 5.8.

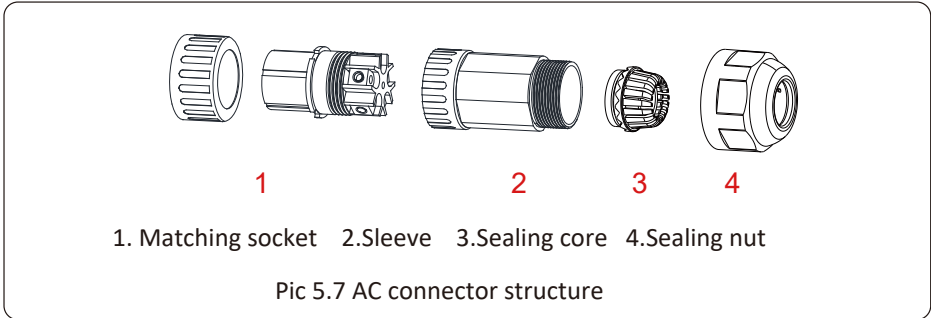

Step 3: Insert the cable (L1, L2, L3, N, PE) into the sealing sleeve.

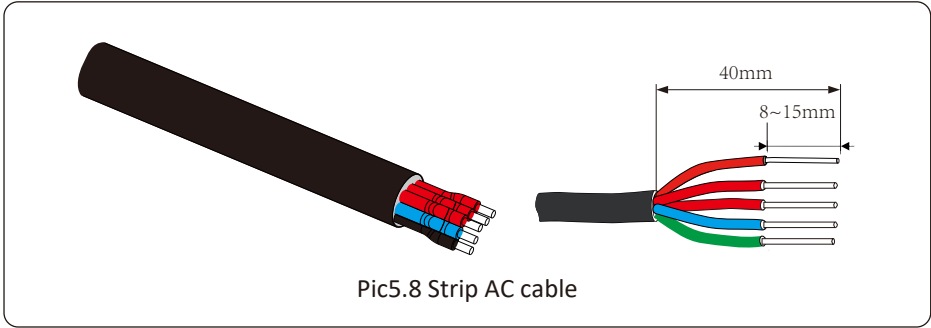

**Warning:**  
Be careful to distinguish the L1, L2,L3,N and PE of the AC cables.

Step 4: Use the hexagon screwdriver, loosen the bolts of the socket in turn, and insert each cable core into the corresponding jack, and set each screw. The connection hole of AC connection terminal labeling is shown in Picture 5.9.



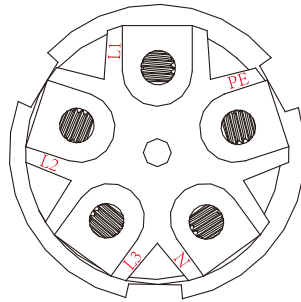

Pic 5.9 AC Connector Hole Pattern

Step 5: Set the sleeve and sealing ring in place.

Step 6: Connect the terminals to the inverter as shown in picture 5.10.

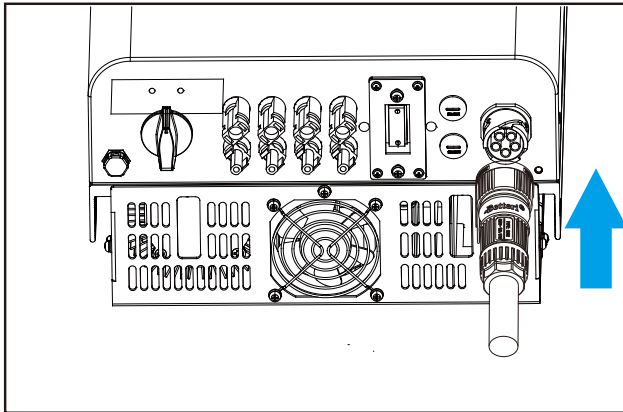

Pic 5.10 AC input connection

### 5.3 The connection of the ground line

Good grounding is good for resisting surge voltage shock and improving EMI performance. Therefore, before connecting AC, DC and communication cables, you need to ground the cable firstly. For a single system, just ground the PE cable. For multiple machine systems, all PE cables of the inverter need to be connected to the same grounding copper platoon to ensure the equipotential connection. The installation of the shell ground wire is shown as picture 5.11.

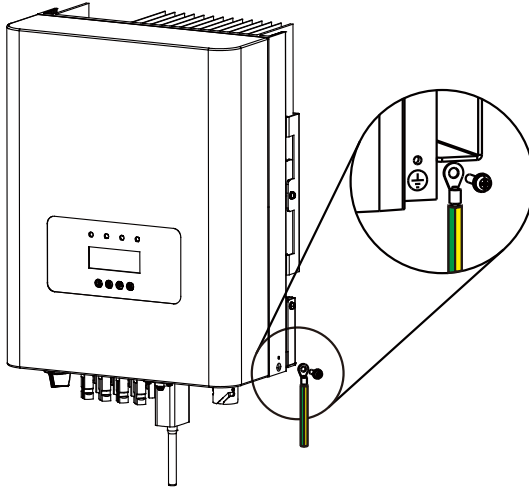

Pic 5.11 The installation of the shell ground wire



**Warning:**

Inverter has built-in leakage current detection circuit, If an external leakage current protection device is connected, its operating current must be greater than 300 mA or higher, otherwise inverter may not work properly.

## 5.4 Max. over current protection device

In order to protect the inverter AC connection, it is recommended to install a circuit breaker to prevent overcurrent. See table 5.3 below.

<i>Inverter</i>	<i>Rated output voltage(V)</i>	<i>Rated output current(A)</i>	<i>Current for protection device(A)</i>
SUN-12K-G03	230	17.4	30
SUN-15K-G03	230	21.8	30

Table 5.3 Recommended current protector specifications

## 5.5 Inverter monitoring connection

Inverter has the function of wireless remote monitoring. The inverter with Wi-Fi function is equipped with Wi-Fi Plug to connect the inverter and network. Wi-Fi Plug's operation, installation, Internet access, APP downloading and other processes are detailed in the instructions.

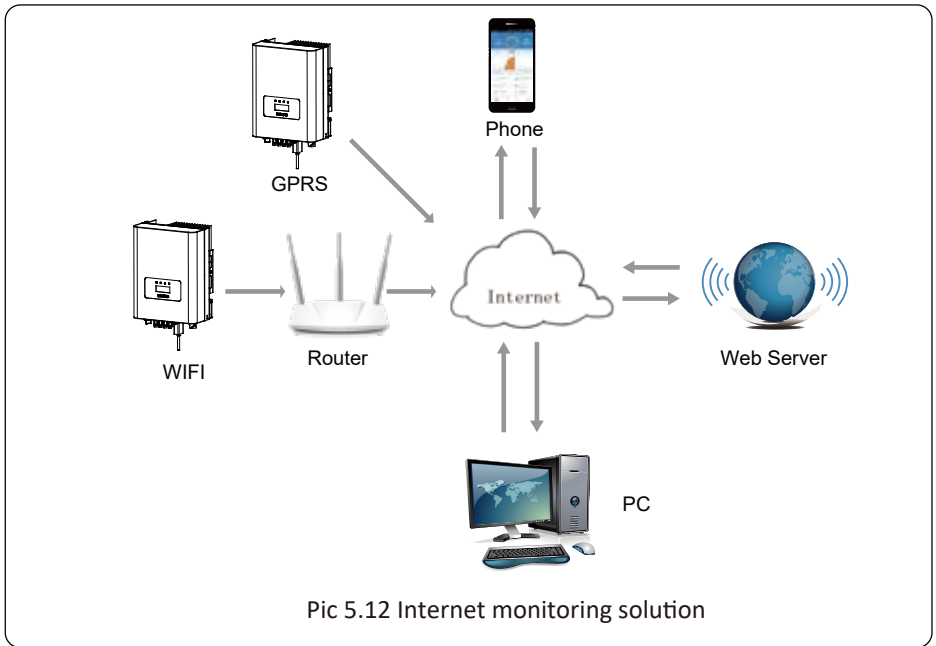

## 5.6 Installation of datalogger

When the inverter is out of the factory, the installation location of datalogger is sealed by a sealed plate as shown in Picture 5.13. When installing the datalogger, remove the sealing plate, replace it with the sealing plate with square hole in the accessories, and tighten the screws. Insert the datalogger into the interface and fix it with a screw. The configuration of the datalogger needs to be performed after various electrical connections have been completed and the inverter DC power on. When the inverter is on the DC power, it is determined whether the datalogger is normally electrified (The LED light shines out of the shell).

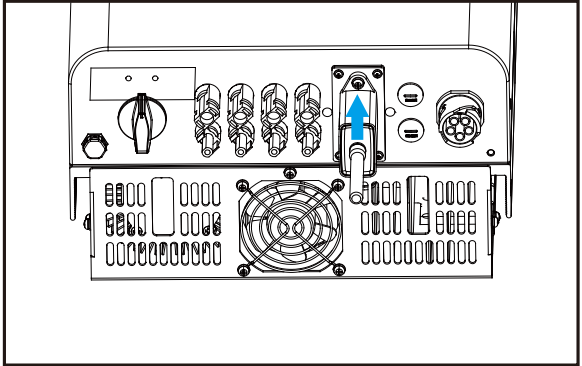

Pic 5.13 Datalogger installation diagram

## 5.7 Configuration of Datalogger

For the configuration of datalogger, please refer to illustrations of the datalogger.

---

## 6. Startup and Shutdown

Before starting the inverter, make sure that the inverter can meet the following conditions, otherwise it may result in fire or damage to the inverter. In this case, we do not undertake any responsibility. At the same time, to optimize the system configuration, it is recommended that the two inputs be connected to the same number of photovoltaic modules.

- a). The maximum open voltage of each set of photovoltaic modules shall not exceed 600VDC under any conditions.
- b). Each input of the inverter must use the same type of photovoltaic module in series.
- c). Total output power of pv shall not exceed the maximum input power of inverter, each photovoltaic modules shall not exceed the rated power of each channel.
- d). The short circuit current of each series of photovoltaic modules cannot be greater than 10A at any time.

### 6.1 Start up the inverter

When start up the three phase string inverter, should follow below steps:

1. First switch on the AC breaker.
2. Turn on the DC switch of the photovoltaic module, and if the panel provides sufficient starting voltage and power, the inverter will start.
3. When the ac voltage and DC voltage are normal, the inverter start-up is ready to begin. The inverter will first check the internal parameters and the grid parameters, while the liquid crystal will show that the inverter is self-checking.
4. If the parameter is within acceptable range, the inverter will generate the normal grid. NORMAL indicator light is on.

### 6.2 Inverter Shutdown

Must follow below steps while shutting down the inverter:

1. Switch off the AC breaker.
2. Wait for 30 seconds, turn off the DC switch (if any), or simply disconnect the DC input connector. The inverter will close the LCD and all LED within two minutes.

## 7 Zero export function via SUN limiter

The inverter has external zero export function. This function is optional. It can collect counter-current power to control the output power of the inverter, so that the power of inverter and load can be offset, and the excess power will not be fed back to the grid. If you purchase the inverter with zero export function, an external zero export device (SUN limiter or energy meter) will be included in the package which is necessary for the function. The SUN limiter shows as Pic 7.1. You can see corresponding line mark next to the green interface. The green terminals on the left are the interface of three-phase AC line (L1, L2, L3) and N Line (N), and the right are the interface between three sets of current sensor and one set of control terminals. SUN limiter will collect voltage and current from these interfaces and send control signals to the inverter.

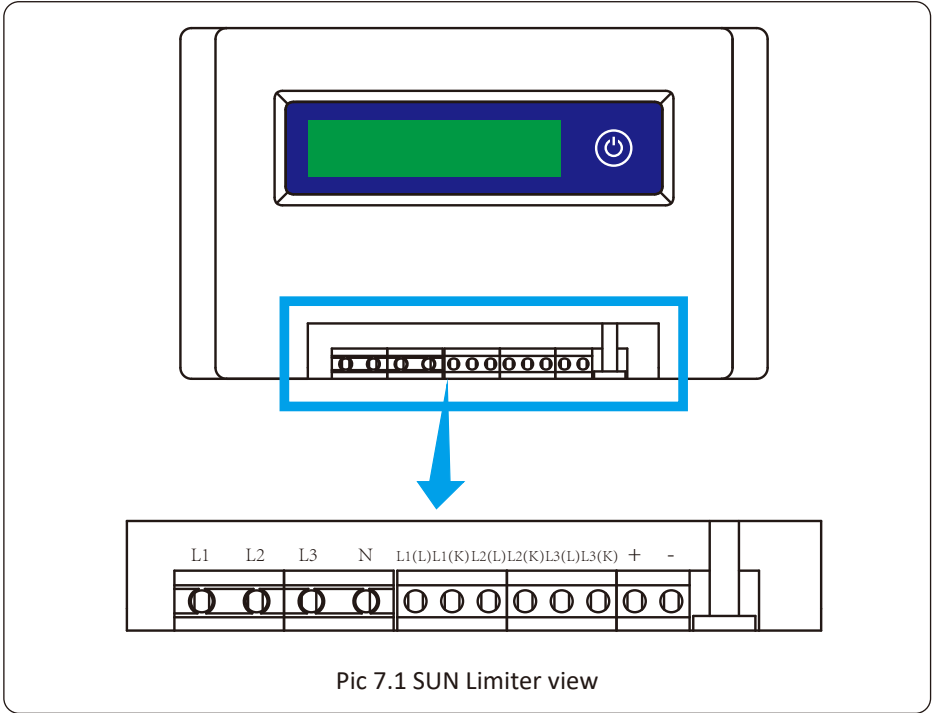

### 7.1 SUN Limiter function wiring diagram

When you are reading this, we believe that you have completed the connection according to the requirements of chapter 5, if you have been running your inverter, and you want to use the limiter function, please turn off AC and DC switch of the inverter, and wait for 5 minutes until the inverter completely discharged. In order to make it easier for you to use the limiter function, we have specifically given the wiring diagram, as shown in Picture 7.2, the yellow/green/red live line (L1, L2, L3) connected to the utility grid live line (U/V/W), blue line means the neutral line.

We recommend installing an AC switch between the inverter outlet and the utility grid, the specs of the AC switch is determined by the load capacity. The AC switch we recommend to connect to the inverter output refer to Table 5.2.

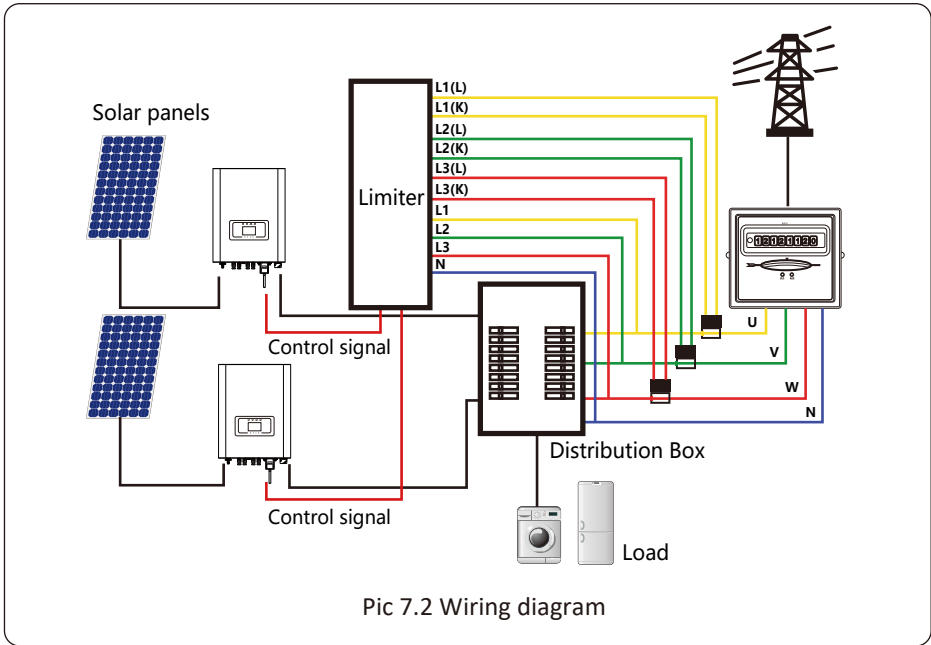

Pic 7.2 Wiring diagram

### 7.2 Connect the SUN limiter to inverter

The SUN limiter will measure the voltage and current of three phases separately, and this manual only introduces the installation steps of one phase, the other two phases are the same. The specific installation steps are as follows:

- (1) Connect SUN limiter to the grid. Connected to the grid is to measure the voltage of grid. Before connect to the grid, please turn off the switch to avoid the risk of electric shock. Choose one wire from the bottom of the three-phase DC switch. (any phase of U,V,W) to connect with L1 terminal, then tighten the line with a screwdriver.
- (2) Connect SUN limiter to clamp sensor. Clamp sensor can measure the current of the AC side, it should be connected to the front side of the load (domestic appliance ect.) to achieve this function. Only when the SUN limiter collects the voltage and current of the same phase can it judge the power of the phase. So the clamp sensor should be connected to the same phase as the before. Open the side buckle of the clamp sensor, then clamp the sensor to the AC line on the DC switch, the arrow direction on the sensor should towards that of the load. The clamp sensor has two lines (shown as below), and the white line corresponds to K terminal, black line corresponds to L terminal. Connect the white line to the L1(L) and L1(K) terminal refer to the line mark of the SUN limiter and tighten the line with screwdriver. This is the whole installation process of one phase.

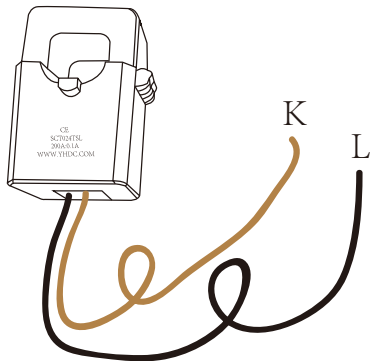

Pic 7.3 Clamp Sensor

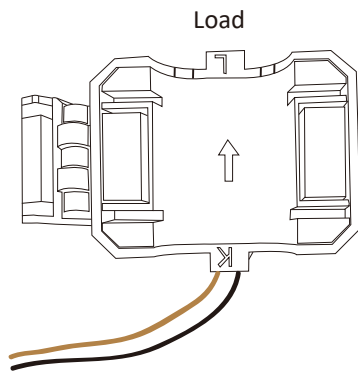

Pic 7.4 Clamp Sensor internal arrow

(3) After you finish the installation in process 1 and 2, connect the N line (N) to the N terminal of the limiter and tighten the line.

(4) Connect the control line. There are two numbers 1 and 2 on the interface of SUN limiter, and the same on the waterproof terminal of the inverter. Twist the waterproof terminal and connect the red line to number 1 and black line to number 2 shown as the picture. After that connect the terminal to the interface of the SUN limiter. The other side of the line should be connected to the control terminal.

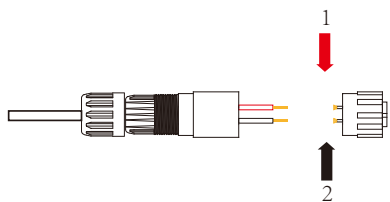

Pic 7.5 Waterproof terminal

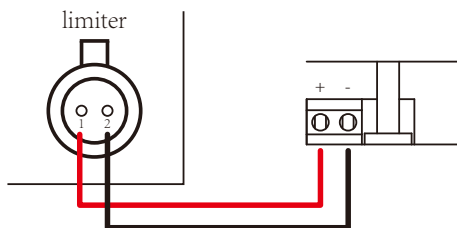

Pic 7.6 Connect limiter to inverter



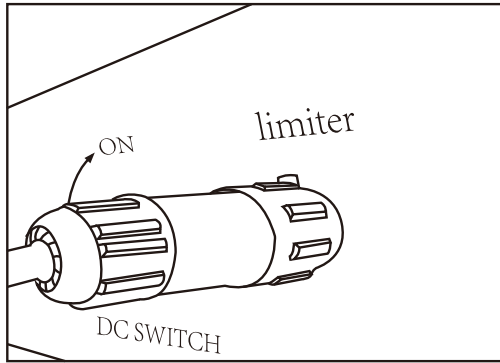

Pic 7.7 Connect terminal to inverter

### 7.3 Use of zero export function

When the connection is completed, the following steps should be referenced to use this function:

1. Turn on the AC switch
2. Turn on the DC switch, Waiting inverter LCD lighting up
3. Press Enter button on the LCD panel in the main interface into the menu options, select [parameter setting] to Enter setup submenu, and then select [running parameters] as shown in figure 7.8, at this time please Input the default password 1234 through pressing the button [up down, confirm], enter the operation parameter setting interface, Shown as figure:



Pic7.8 Parameter setting



Pic 7.9 Limit switch

4. Operate the button [up down], move setting cursor to limit function and press the button [enter]. At this time you can turn on or turn off the limit function by choosing [up down] button, please press [enter] button to confirm when setting done.
5. Move the cursor to [confirm] , press ENTER to save the settings and exit the running parameters page, otherwise the settings are invalid.
6. If set up successfully, you can return to the menu interface, and display the LCD to [home page] by press the [up down] button. If it displayed as [utility power], the limiter function settings will be completed. Shown as picture 7.10.



Pic 7.10 Limiter function turn on

- [utility power] showing positive means grid power is consuming energy, and there is no backflow. If [utility power] shows negative, which means there's excess PV energy flows to grid or current transformer arrow direction is in wrong direction. Please read more on chapter 7.9.
- After properly connection is done, wait for inverter starting. If the power of the PV array meets the current power consumption, the inverter will maintain a certain output to counteract the power of the grid without backflow .

## 7.4 Zero-export function (Option)

The string inverter supports zero-export function via Energy meter / SUN-Limiter. Based on continuously data communication, once the Limiter or energy meter detects power export to the grid, it will send the information to the inverter and then inverter will ramp down its active power according to match the load demand and achieve zero export. The Zero-export function is optional. If you buy the inverter with zero-export function via energy meter, energy meter will be included in the package which is necessary for zero-export function.

### 7.4.1 Zero-export function via energy meter

When you are reading this, we believe that you have completed the connection according to the requirements of chapter 5, if you have been running your inverter at this time, and you want to use the zero-export function, please turn off AC and DC switch of the inverter, and wait for 5 minutes until the inverter completely discharged. Please follow below Picture 7.11 to connect the energy meter.

For system wiring diagram, the red line refers to L line (L1, L2, L3), the black line refers to the neutral line (N). Connecting energy meter RS485 cable to inverter's RS485 port. It's recommended to install an AC switch between the inverter and the utility grid, the specs of the AC switch are determined by the power of load.

If there is no integrated DC switch inside the inverter you purchased, we commend you to connect the DC switch. The voltage and current of the switch depend on the PV array you access.

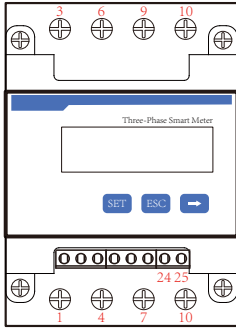

CHINT DTSU666

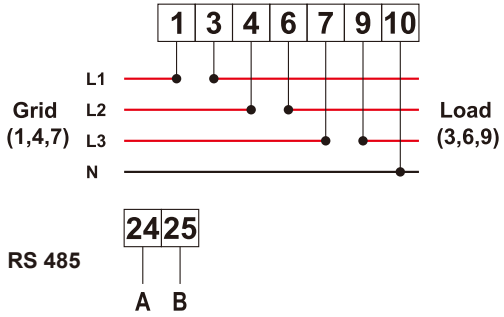

Pic 7.11 CHINT meter

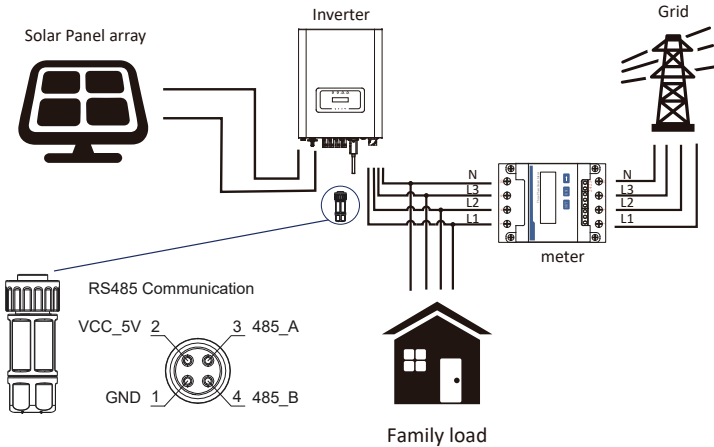

Pic 7.12 Connection diagram of CHINT meter



**Warning:**

Ensuring grid input cables connect 1/4/7/10 port of energy meter, and inverter AC output cables connect 3/6/9/10 port of energy meter when connecting.

## 7.4.2 Use of zero-export function

When the connection is completed, the following steps should be referred to use this function:

1. Turn on the AC switch.
2. Turn on the DC switch, waiting for the inverter's LCD is turned on.
3. Press Enter button on the LCD panel in the main interface into the menu options, select [parameter setting] to enter setup submenu, and then select [running parameters] as shown in picture 7.13, at this time please input the default password 1234 through pressing the button [up down, enter], enter the operation parameter setting interface, shown as picture 7.14.



Pic 7.13 Parameter setting



Pic 7.14 Meter switch

4. Operate the button [up down], move setting cursor to energy meter and press the button [enter]. At this time you can turn on or turn off the energy meter by choosing [up down] button, please press [enter] button to confirm when setting done.
5. Move the cursor to [OK], press [enter] to save the settings and exit the running parameters page, otherwise the settings are invalid.
6. If set up successfully, you can return to the menu interface, and display the LCD to [home page] by press the [up down] button. If it displays [meter power XXW], the zero-export function setting is completed. Shown as picture 7.15.



Pic 7.15 Zero-export function via energy meter turn on

7. Meter power XXW shows positive means grid is supplying the load, and no power fed into grid. if meter power shows negative, it means PV energy is being sold to grid or energy meter wiring connection has problem.
8. After properly connection is done, wait for inverter starting. If the power of the PV array meets the current power consumption, the inverter will keep a certain output to counteract the power of the grid without backflow .

---

## 7.5 Notes while using zero export function

For your safety and the operation of limiter function of the inverter, we put forward the following suggestions and precautions:



**Warning:**

Under zero export mode we strongly recommend that the two PV arrays are formed by the same number of PV panels of the same size, which will make the inverter more responsive to limit the power.



**Safety Hint:**

While the utility power is negative and inverter has no output power, that means the orientation of the current sensor is wrong, please turn off the inverter and change orientation of the current sensor.

*(when using SUN limiter, the arrow of current sensor points to the load)*



**High Temperature Hazard:**

When using SUN limiter, the current sensor of limiter function needs to be clamped on the fire line of the grid connected to the inverter, otherwise inverter cannot able to normal operate.

# 8. General Operation

During normal operation, the LCD shows the current status of the inverter, including the current power, total generation, a bar chart of power operation and inverter ID, etc. Press the Up key and the Down key to see the current DC voltage, DC current, AC voltage, AC current, inverter radiator temperature, software version number and Wifi connection state of the inverter.

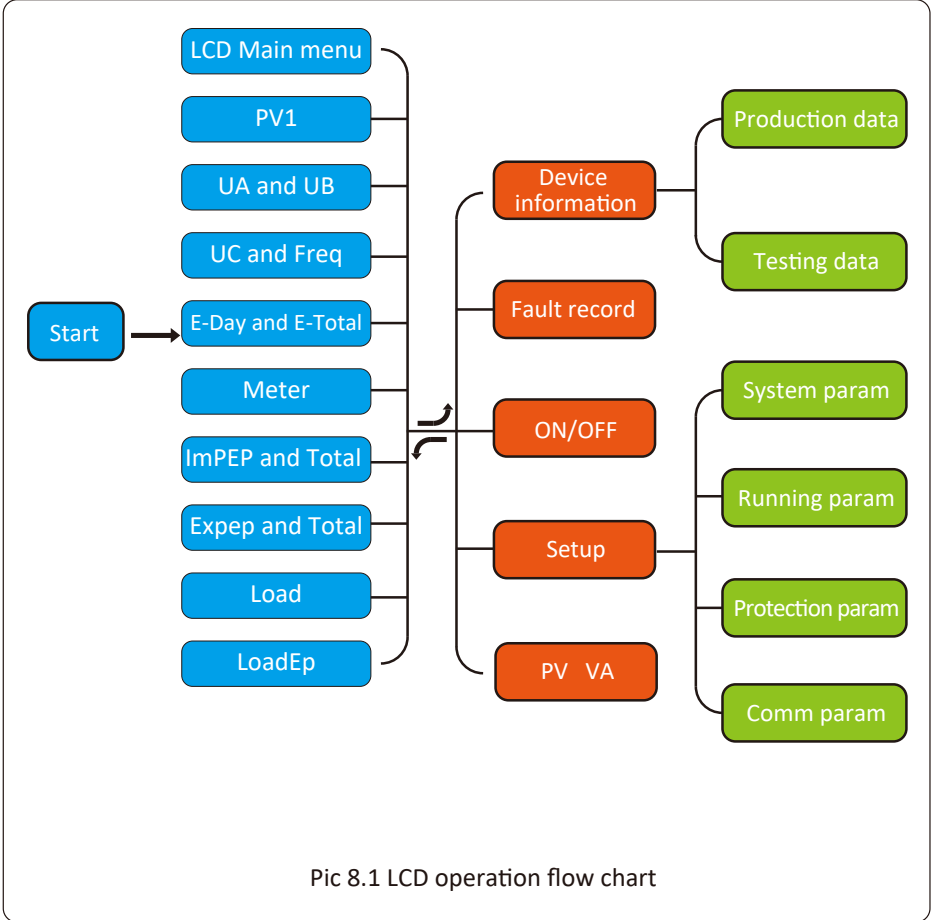

## 8.1 The initial interface

From the initial interface, you can check PV power, PV voltage, grid voltage, inverter ID, model and other information.

```
Power: 0W
State: Standby
```

```
Power: 0W
State: Com_Error
```

Pic 8.2 The initial interface

Press UP or Down, you can check inverter DC voltage, DC current, AC voltage, AC current and inverter temperature.

```
PV1: 0.0V 0.0A
```

```
UA: 234V 0.0A
```

```
UB: 0V 0.0A
```

Pic 8.3 PV input voltage and current information

Pic 8.4 Grid voltage and current information

```
UC: 0V 0.0A
```

```
Freq: 0.00Hz
```

```
21 - 05 - 2020
```

```
15 : 57 : 08
```

Pic 8.5 Grid voltage and frequency

Pic 8.6 Time

```
Meter
```

```
Power: 0W
```

Pic 8.7 Meter power

```
ImpEp: 0.00KWh
```

```
Total : 0.00KWh
```

Pic 8.8 Electrical energy

ImpEp: Daily energy purchased from grid;  
Total: Total energy purchased from grid.

## 8.2 Submenus in the Main Menu

There are five submenus in the Main Menu.

```
ExpEp: 0.00KWh
```

```
Total : 0.00KWh
```

Pic 8.9 Electrical energy

ExpEp: Daily energy sold to grid;  
Total: Total energy sold to grid.



Pic 8.10 Load power

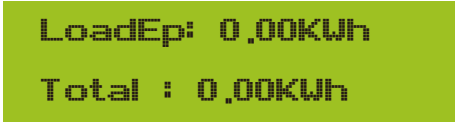

LoadEp: Daily consumption;  
Total: Total energy consumption.

Pic 8.11 Load consumption



E-Day: Daily generation;  
E-Total: Total generation.

Pic 8.12 PV generation

You can see the LCD software Ver0201 and inverter software Ver1970. In this interface, there are parameters such as rated power communication addresses.

### 8.2.1 Device information

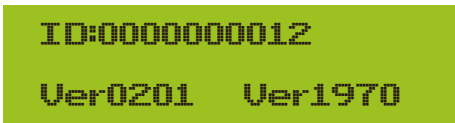
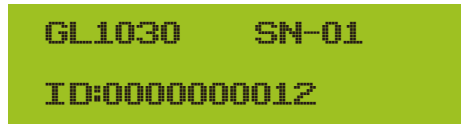

Pic 8.13 Device information

### 8.2.2 Fault Record

It can keep Eight fault records in the menu including time, customer can deal with it depends on the error code.

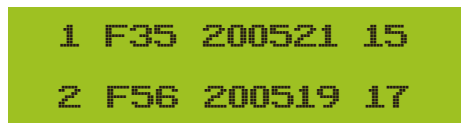

Pic 8.14 Fault Record



### 8.2.3 ON/OFF setting

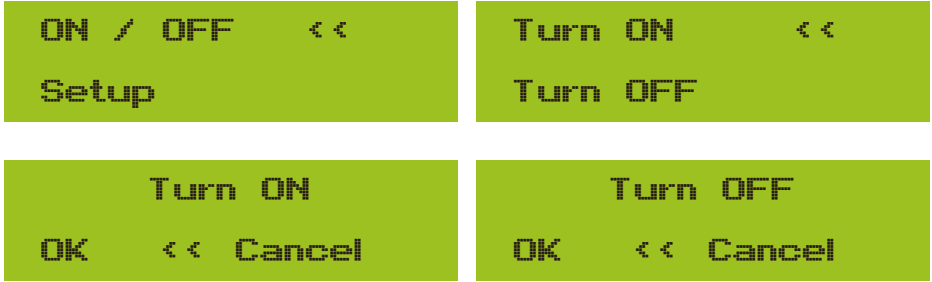

Pic 8.15 ON/OFF setting

When the inverter is turned off, it stops working immediately, and go to standby mode and then will go to self-test program again. If it passed the self-test, it will start to work again.

### 8.2.4 PV VA setting



Pic 8.16 PV String current

Each PV string current and this function is optional.

### 8.2.5 Parameter setting

There are five submenus in the setup. Setting includes system param, run param, protect param, comm: param. All of these information for maintenance reference.



Pic 8.17 Submenus of the parameter setup

### 8.3 System param setting

System Param includes time set, language set, display set and factory reset.



Pic 8.18 System Param

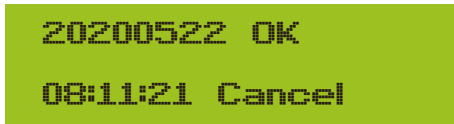

Pic 8.19 Time

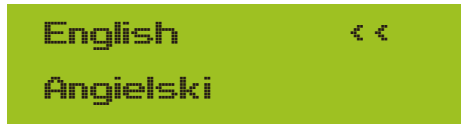

Pic 8.20 Language



Pic 8.21 LCD Screen settings



Pic 8.22 Delay time set



Pic 8.23 Reset to factory setting

### 8.4 Running param set



**Note:**

Password required-- only for access-authorized engineer. Un-authorized access may avoid the warranty. The initial password is 1234.



Pic 8.24 Password

### 8.4.1 ActiveP set

```
ActiveP      0%
ReactiveP    0% <<
```

Pic 8.25

Adjust the output active power in %  
ReactiveP: Adjust reactive power output in %

```
PF           1,000
Fun_ISO      OFF <<
```

Pic 8.26

Fun\_ISO: Insulation resistance detection

```
Fun_RCD      OFF
SelfCheck    0s <<
```

Pic 8.27

Fun\_RCD: Residual current detection  
Self-check: Inverter's self-check time. The default value 60s

```
Island       OFF
Meter        OFF <<
```

Pic 8.28

Island: Anti-islanding protection  
Meter: Energy meter. If inverter will connect meter, then set here to ON

```
Limiter      ON
P_Factor     0,00 <<
```

Pic 8.29

Limiter: If inverter will connect SUN limiter, then set here to ON  
P. Factor: Reactive power generation correction factor

```
MPPT Num     0 <<
WindTurbine
```

Pic 8.30

WindTurbine: when connecting windturbine, turn on this item.



Those parameters is used for setup wind trubine MPPT curve.

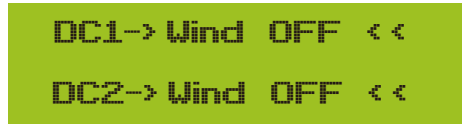

Pic 8.31 WindTurbine set

### 8.5 Protect Param



**Note:**

Engineer Only.

We will set the param depends on the safety requirements, so customers don't need to reset it. The password is same as 8.4 Running param

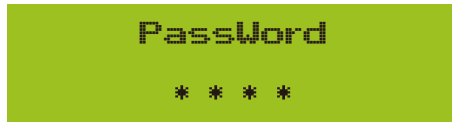

Pic 8.32 Password

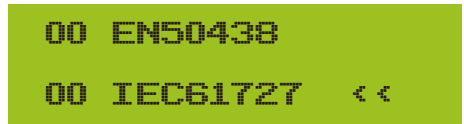
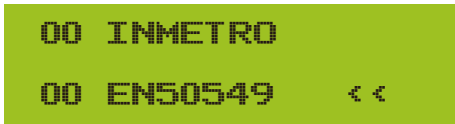

**Note:**

Engineer only.

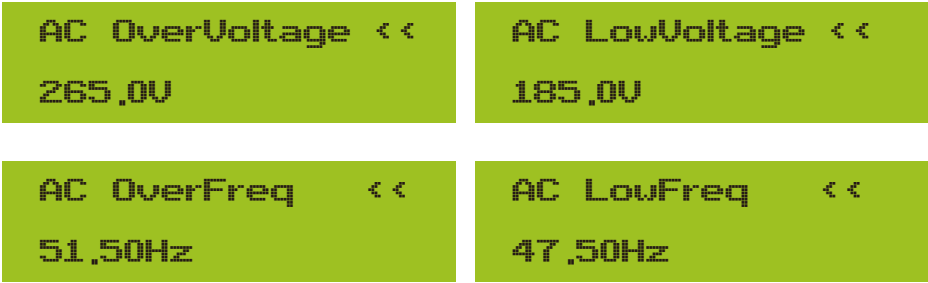

Pic 8.33 “CUSTOMIZED”

Please set the proper grid parameters according to the requirements of your current country's grid regulations. If you are not clear about it, please consult your installer.

**8.6 Com. param set**

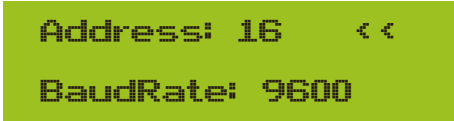

Pic 8.34 Com. Param

**9. Repair and Maintenance**

String type inverter doesn't need regular maintenance. However, debris or dust will affect heat sink's thermal performance. It is better to clean it with a soft brush. If the surface is too dirty and affect the reading of LCD and LED lamp, you can use wet cloth to clean it up.



**Warning:** When the device is running, the local temperature is too high and the touch can cause burns. Turn off the inverter and wait for it cooling, then you can clean and maintain.



**Warning:** No solvent, abrasive materials or corrosive materials can be used for cleaning any parts of the inverter.

**10. Error information and processing**

Inverter has been designed in accordance with international grid tied standards for safety, and electromagnetic compatibility requirements. Before delivering to the customer the inverter has been subjected to several tests to ensure its optimal operation and reliability.

## 10.1 Error code

If there is any failure, the LCD screen will display an alarm message. In this case, the inverter may stop feeding energy into the grid. The alarm description and their corresponding alarm messages are listed in Table 10.1.

<b>Error code</b>	<b>Description</b>	<b>Solutions</b>
F10	Auxiliary switch power supply failure	<ol style="list-style-type: none"> <li>1. Turn off DC/AC switch, and turn on DC/AC switch 10mins later;</li> <li>2. If the fault still exists, please contact us for help.</li> </ol>
F13	Reserved	<ol style="list-style-type: none"> <li>1. Loss of one phase or AC voltage detection part failure or relays not closed;</li> <li>2. Seek help from us, if can't go back to normal state.</li> </ol>
F15	AC firmware over current	<ol style="list-style-type: none"> <li>1. Restart inverter and check whether it is in normal;</li> <li>2. Seek help from us, if can't go back to normal state.</li> </ol>
F16	GFCI(RCD) Ac leakage current fault	<ol style="list-style-type: none"> <li>1. Check PV module connection;</li> <li>2. Turn off the DC/AC switch and then wait 1~2 minute, then turn on the DC/AC switch again;</li> <li>3. Seek help from us, if can't go back to normal state.</li> </ol>
F18	AC over current fault of hardware	<ol style="list-style-type: none"> <li>1. Restart inverter and check whether it is in normal;</li> <li>2. Seek help from us, if can't go back to normal state.</li> </ol>
F20	DC over current fault of the hardware	<ol style="list-style-type: none"> <li>1. Check DC input power is within the allowed range;</li> <li>2. Restart inverter and check whether it is in normal;</li> <li>3. Seek help from us, if can't go back to normal state.</li> </ol>
F23	AC leakage current is transient over current	<ol style="list-style-type: none"> <li>1. Please wait for a while and check whether it is normal;</li> <li>2. If still same, and turn off the DC switch and AC switch and wait for one minute and then turn on the DC/AC switch;</li> <li>3. Seek help from us, if can't go back to normal state.</li> </ol>
F24	DC insulation impedance failure	<ol style="list-style-type: none"> <li>1. Check PV panels connection and restart inverter. This problem is caused by the PV side usually;</li> <li>2. If the fault still exists, please contact us for help.</li> </ol>
F30	AC main contactor failure	<ol style="list-style-type: none"> <li>1. Turn off the DC/AC switch and then wait 1~2 minutes, then turn on the DC/AC switch again;</li> <li>2. If the fault still exists, please contact us for help.</li> </ol>
F35	No AC grid	<ol style="list-style-type: none"> <li>1. Check AC grid voltage;</li> <li>2. Check whether the AC output connection is in good condition;</li> <li>3. If the fault still exists, please contact us for help.</li> </ol>
F39	AC over current (one cycle) Grid voltage fault	<ol style="list-style-type: none"> <li>1. Wait for inverter to return to normal;</li> <li>2. Disconnect DC switch and AC switch, and reconnect DC switch and AC switch 10min later to restart the inverter;</li> <li>3. If the fault still exists, please contact us for help.</li> </ol>

<b>Error code</b>	<b>Description</b>	<b>Solutions</b>
F41	AC Line W, U over voltage Generally, the inverter will reconnect to grid after grid returns to normal. If this fault occurs repeatedly then check as follow:	<ol style="list-style-type: none"> <li>1. Measure the actual grid voltage and compare with inverter set value. if the grid voltage measured is higher than set value, and then ask help from local electrically company for solution;</li> <li>2. Check whether voltage protection parameters are appropriate via LCD or monitoring platform;</li> <li>3. Check whether the cross-sectional area of AC cable meets the requirements;</li> <li>4. If the fault is not caused by foregoing reasons and still exists, please contact us for help.</li> </ol>
F42	AC Line W, U low voltage Generally, the inverter will reconnect to grid after grid returns to normal. If this fault occurs repeatedly then check as follow:	<ol style="list-style-type: none"> <li>1. Measure the actual grid voltage and compare with inverter set value. if the grid voltage measured is lower than set value, and then ask help from local electrically company for solution;</li> <li>2. Check whether voltage protection parameters are appropriate via LCD or monitoring platform;</li> <li>3. If the fault is not caused by foregoing reasons and still exists, please contact us for help.</li> </ol>
F43	AC Line V, W over voltage	1. Refer to F41.
F44	AC Line V, W low voltage	1. Refer to F42.
F45	AC Line U, V over voltage	1. Refer to F41.
F46	AC Line U, V low voltage	1. Refer to F42.
F47	AC Over frequency Generally, the inverter will reconnect to grid after grid returns to normal. If this fault occurs repeatedly then check as follow:	<ol style="list-style-type: none"> <li>1. Measure the actual grid frequency and compare with inverter set value. if the grid frequency measured is higher than set value, and then ask help from local electrically company for solution;</li> <li>2. Check whether frequency protection parameters are appropriate via LCD or monitoring platform;</li> <li>3. If the fault is not caused by foregoing reasons and still exists, please contact us for help.</li> </ol>
F48	AC lower frequency Generally, the inverter will reconnect to grid after grid returns to normal. If this fault occurs repeatedly then check as follow:	<ol style="list-style-type: none"> <li>1. Measure the actual grid frequency and compare with inverter set value. if the grid frequency measured is lower than set value, and then ask help from local electrically company for solution;</li> <li>2. Check whether frequency protection parameters are appropriate via LCD or monitoring platform;</li> <li>3. If the fault is not caused by foregoing reasons and still exists, please contact us for help.</li> </ol>
F55	DC busbar voltage is too high	<ol style="list-style-type: none"> <li>1. Check PV input voltage and Ubus voltage via LCD or monitoring platform;</li> <li>2. Disconnect DC switch and AC switch, and reconnect DC switch and AC switch 10min later to restart the inverter;</li> <li>3. Check whether the inverter works in export control mode. If so, decreasing PV panel number in series;</li> <li>4. If the fault still exists, please contact us for help.</li> </ol>

<b>Error code</b>	<b>Description</b>	<b>Solutions</b>
F56	DC busbar voltage is too low	<ol style="list-style-type: none"> <li>1. Check PV input voltage and Ubus voltage via LCD or monitoring platform;</li> <li>2. Disconnect DC switch and AC switch, and reconnect DC switch and AC switch 10min later to restart the inverter;</li> <li>3. If the fault still exists, please contact us for help.</li> </ol>
F64	IGBT heat sink high temperature Heat sink temperature is too high	<ol style="list-style-type: none"> <li>1. Check whether the work environment temperature is too high;</li> <li>2. Turn off the inverter for 10mins and restart;</li> <li>3. Seek help from us, if can't go back to normal state.</li> </ol>

**Table10.1 Error codes and their solutions**



**Note:**

If your string inverter has any of the fault information shown in Table 10-1, and when you reset the machine and still don't solve the problem, please contact our distributor and provide the below details:

1. Serial number of the inverter;
2. The distributor/dealer of the inverter(if available);
3. Installation date;
4. The discription of problem(include LCD'error code and LED status indicator lights);
5. Your contact details.



## 11.Specification

<i>Model</i>	<i>SUN-12K-G03</i>	<i>SUN-15K-G03</i>
<b>Input Side</b>		
Max.DC Power(kW)	15.6	19.5
Max.DC Input Voltage(V)	1000	
Start-up DC Input Voltage(V)	250	
MPPT Operating Range(V)	200~800	
Max.DC Input Current(A)	11+22	
Number of MPPT/Strings per MPPT	2/1+2	
<b>Output Side</b>		
Rated Output Power(kW)	12	15
Max.Active Power(kW)	13.2	16.5
Rated AC Grid Voltage(V)	230/400	
AC Grid Voltage Range(V)	277 ~ 460 (this may vary with grid standards)	
Rated Grid Frequency(Hz)	50/60(Optional)	
Operating Phase	Three phase	
Rated AC Grid Output Current(A)	17.4	21.8
Max.AC Output Current(A)	19.1	23.9
Output Power Factor	0.8 leading~0.8 lagging	
Grid Current THD	<2%	
DC Injection Current(mA)	<0.5%	
Grid Frequency Range	47-52 or 57-62 ( optional)	
<b>Efficiency</b>		
Max.Efficiency	98.5%	
Euro Efficiency	97.5%	
MPPT Efficiency	>99%	
<b>General Data</b>		
Size(mm, W×H×D)	330×430×193.5	
Weight(kg)	17	
Topology	Transformerless	
Internal consumption	<1W(Night)	
Operating temperature	-25 ~ 65 C	
Ingress protection	IP65	
Noise Emission(Typical)	<45dB	
Cooling Concept	Smart cooling	
Max. operation altitude	2000m	
Designed Lifetime	>20 Years	
Grid Connection Standard	EN50549, IEC61727, VDE 0126-1-1, IEC62109-1-2	
Operation surrounding humidity	0~100%	
Stafy EMC / Standard	IEC62109-1/-2,EN61000-6-1,EN61000-6-3	
<b>General Data</b>		
DC Connection	MC-4 mateable	
AC Connection	IP65 rated plug	
Display	LCD1602	
Interface	RS485/RS232/Wifi/LAN	

## NINGBO DEYE INVERTER TECHNOLOGY CO., LTD.

Add: No.26-30, South Yongjiang Road, Beilun, 315806, Ningbo, China

Tel: +86 (0) 574 8622 8957

Fax: +86 (0) 574 8622 8852

E-mail: [service@deye.com.cn](mailto:service@deye.com.cn)

Web: [www.deyeinverter.com](http://www.deyeinverter.com)

502012005 Ver: 2.0, 2020-11