

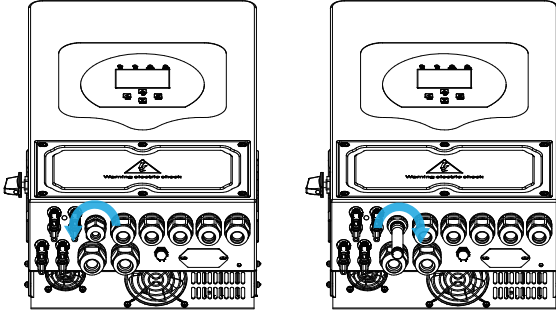

Commissioning Steps of The Smart Devices

1.1 Instruction of installation

Step1: Unscrew the sealing cover of one COM inlet of the inverter, and fix the smart TX to this inlet.



Step2: Connect the meter port of the inverter and the RJ45 port of the smart TX using the communication cable from the accessory package.

Step3(Optional): If the meter port of inverter can't output 5V DC power, please use the external USB to Type-C power cable to connect the Type-C port of Smart TX and the external power source.

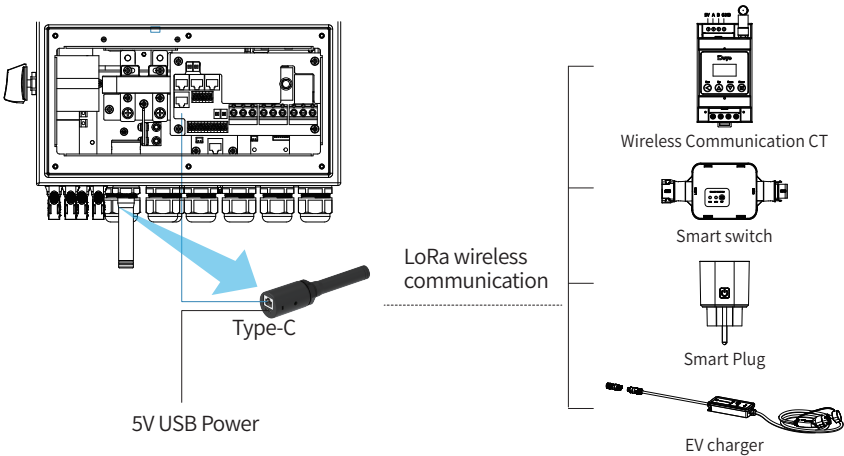

1.2 LCD operation flow chart

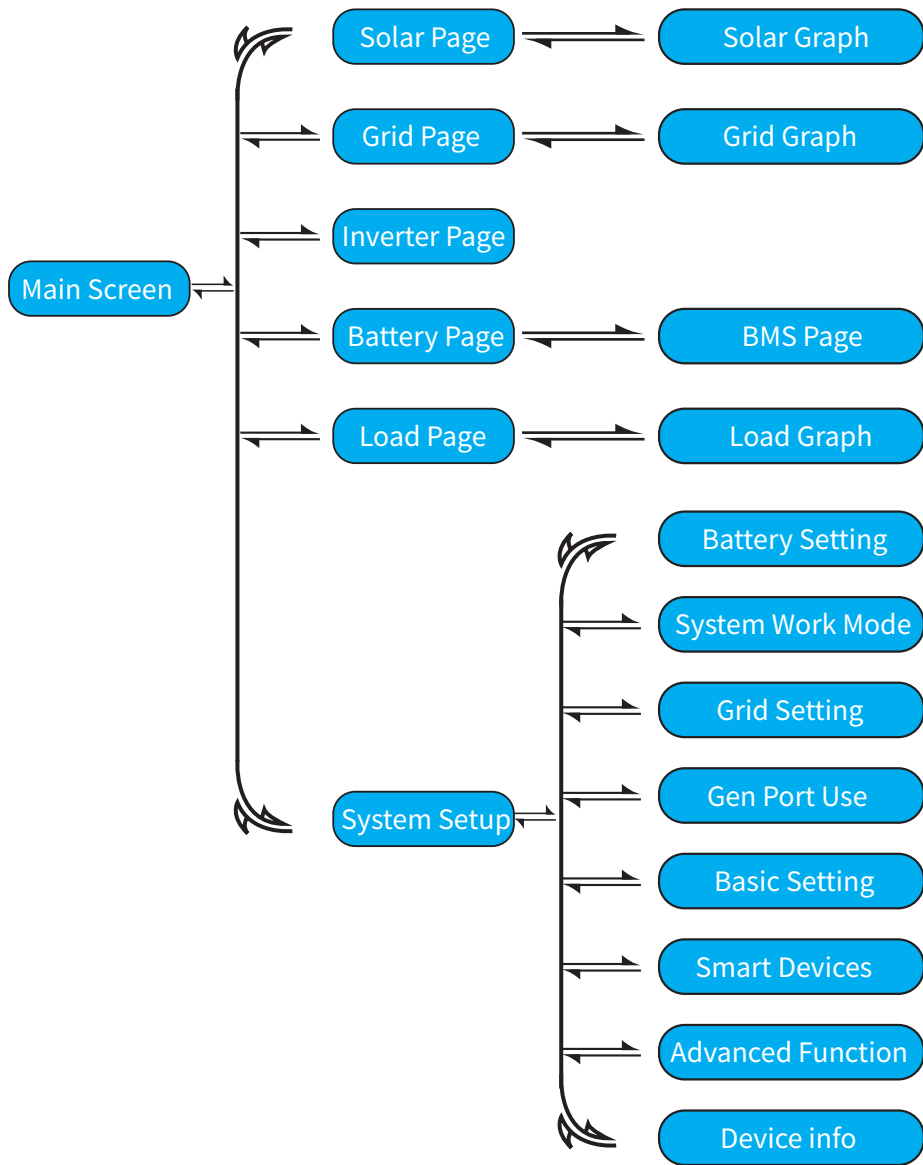

Note: If the Smart Devices option is not available under System Setup on your hybrid inverter's LCD display, please contact your after-sales support team to upgrade the inverter's firmware. If your inverter's hardware version is too old, it may not be compatible with any firmware version that includes the Smart Devices feature—final eligibility must be confirmed by your after-sales support team.

1.3 System Setup Menu

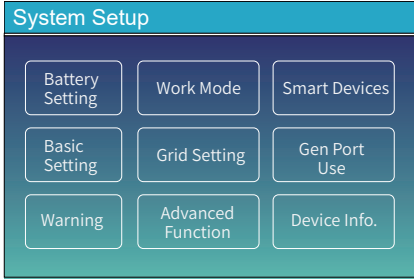

Click on the "Smart Devices" item in the upper right corner of the "System Setup" page to enter the "Smart Devices" page.

1.4 Smart Devices Menu

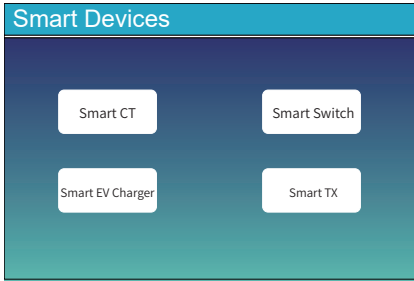

There are four function options on the "Smart Devices" page: Smart CT, Smart Switch, Smart EV Charger, Smart TX.

1.4.1 Smart CT



Click on "Smart CT" item in the upper left corner of "Smart Devices" page to enter the left page. On this page, you can enter up to 2 serial numbers of the smart CT and determine whether to enable them. The series number of Deye smart CT can be found on its nameplate.

Note: (1)CT1 corresponds to the wireless CT meter installed at the grid connection point, and CT2 corresponds to the wireless CT meter installed on the on-grid inverter side.
(2)After enabling the Smart CT on the inverter LCD or APP, Please refer to the below steps to perform channel scanning to establish LoRa communication with the smart TX.



Click the link below to download the user manual of the smart CT: "https://hqcndn.hqsmartcloud.com/deyeinverter/2025/09/19/%E3%80%90b%E3%80%91manual_sun-smart-ct01_30240301004_804_20250919_en-1.pdf".

Steps of "SN input"



Step 1: After clicking the SN input text boxes beside CT1 and CT2 on the Smart CT page respectively, you can enter the "SN input" page.
Step 2: Click the "Edit SN" button and then click the "OK" button on the "SN input" page, the soft keyboard will appear on the screen so you can enter the SN serial number of the smart devices, which can be found on the label of the smart devices itself.
Step 3: After completing the input and confirming it is correct, click "OK" to save the setting.

1.4.2 Smart Switch

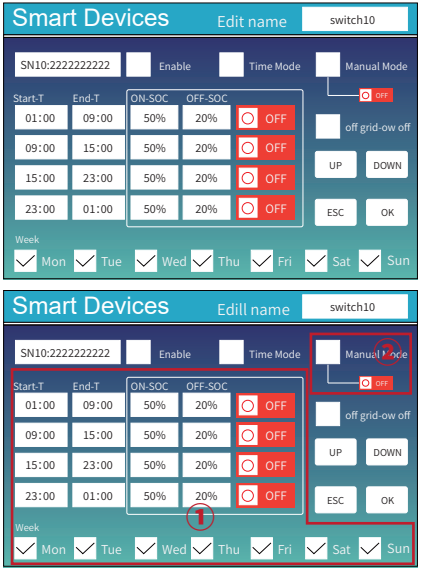

Click on "Smart Switch" item in the upper right corner of "Smart Devices" page to enter the left page. Under this function, you can add up to 10 smart Switch/Plug.

Click "UP" and "DOWN" buttons on the screen to jump to any smart switch/plug you want to set. After checking the checkbox in front of "Enable" in the upper left corner of this page, you can follow the "SN input" steps to enter the series number of each Smart switch/plug and you can also customize the name of each switch/plug following steps of "Edit name".

Note: After adding smart switches/plugs to the inverter and ticked the 'Enable' option, please refer to the flowchart below (including in the user manual of the smart switch/plug) for channel scanning in order to establish LoRa communication with the smart TX.

Time mode: Use the programmable parameters on the zone 1 to control the ON/OFF status of smart switch/plug, and these programmable parameters

also have the corresponding settable options on the APP or website of the cloud platform. The 24 hours of a whole day will be divided into four time periods (Only the fourth time period can cross zero o'clock), and the ON/OFF status of the smart switch/plug can be controlled separately in each time period.

Start-T: The starting time point of each time period.

End-T: The end time point of each time period.

ON-SOC: Be valid only when the ON/OFF button of this time period is in ON status. When the battery SOC rises to this set value, this smart switch/plug will be turned on automatically.

OFF-SOC: Be valid only when the ON/OFF button of this time period is in ON status. When the battery SOC drops to this set value, this smart switch/plug will be turned off automatically.

ON/OFF button: In the OFF state, this smart switch/plug will always be turned off during the current time period. In the ON state, this smart switch/plug will be turned on/off automatically based on the judgment of ON-SOC and OFF-SOC.

Week: To choose which days of the week need to follow the above programmable schedule. If all options are not checked, it is equivalent to all options being checked.

Manual mode: Use the ON/OFF button on the zone 2 of the screen, the power button of the smart plug or the "SET" button of the smart switch, and the corresponding ON/OFF button on the APP and website of the cloud platform to control the ON/OFF status of this smart switch/plug manually. Remember that the manual mode and time mode can not be enabled in the same time.

off grid-sw off: After enabling, when the inverter switches from on-grid mode to off-grid mode, all smart switches/plugs connected to this inverter will be turned off automatically.

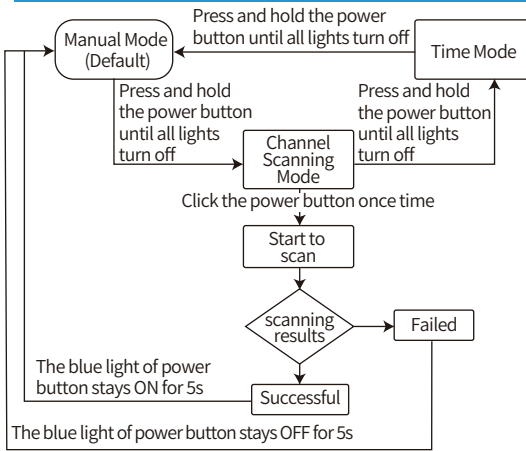

Indicator	Channel scanning	Updating
Blue light	Blink 4 times in 1s, and cycle at 2s intervals: Ready to scan channel. ↓ Click the power button once ↓ In a steady flashing state: Channel scanning ↓ Stay ON for 5s: Channel scan successful Stay OFF for 5s: Channel scan failed	Steady light
Green light		Steady light

Click the link below to download the user manual of the smart plug : "https://hqcdn.hqsmartcloud.com/deyeinverter/2025/09/19/%E3%80%90b%E3%80%91manual_sun-smart-plug01-f30240301004772_20250919_en-1.pdf".

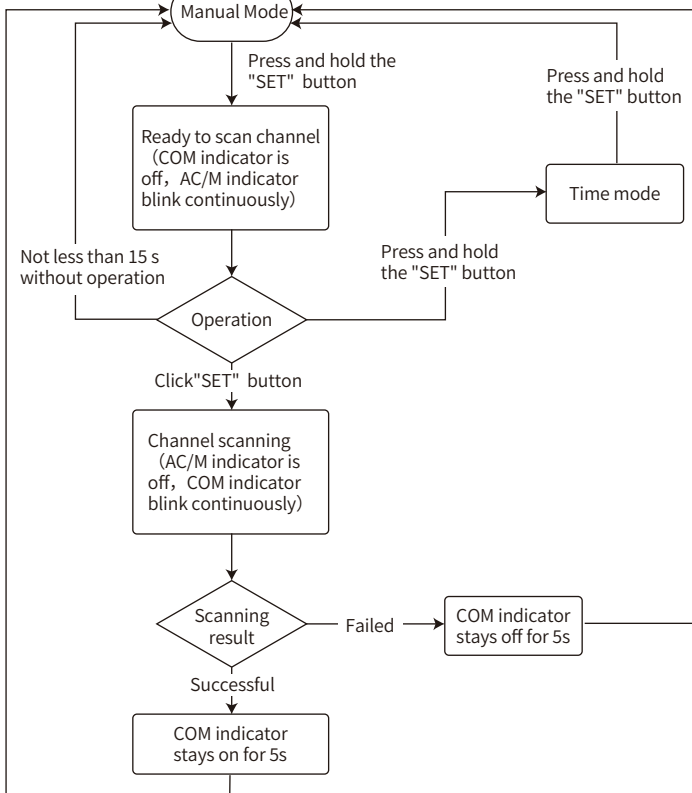

Click the link below to download the user manual of the smart switch: "https://hqcdn.hqsmartcloud.com/deyeinverter/2025/09/19/%E3%80%90b%E3%80%91manual_sun-smart-switch01p330240301004498_20250919_en-1.pdf".

Steps of "Edit Name"

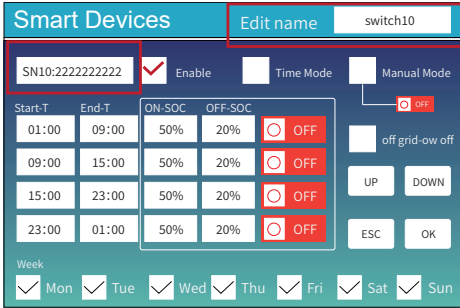

The "Smart Devices" screen shows a list of devices. The first device, "switch10", is selected. The "Edit name" button is highlighted in red. Below the device list, there are settings for "Enable", "Time Mode", and "Manual Mode". A table shows the schedule for the device, with columns for "Start-T", "End-T", "ON-SOC", "OFF-SOC", and a status indicator. The status indicator is currently "OFF". Below the table, there are buttons for "UP", "DOWN", "ESC", and "OK". At the bottom, there is a "Week" section with checkboxes for each day of the week, all of which are checked.

Start-T	End-T	ON-SOC	OFF-SOC	Status
01:00	09:00	50%	20%	OFF
09:00	15:00	50%	20%	OFF
15:00	23:00	50%	20%	OFF
23:00	01:00	50%	20%	OFF

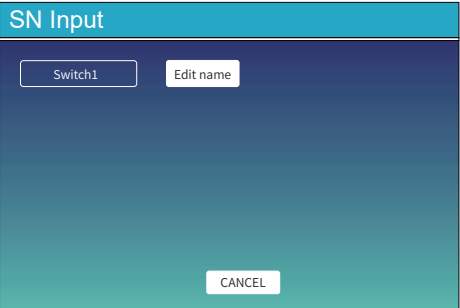

The "SN Input" screen shows a text input field containing "switch10" and an "Edit name" button. Below the input field, there are buttons for "UP" and "DOWN". At the bottom, there are "CANCEL" and "OK" buttons.

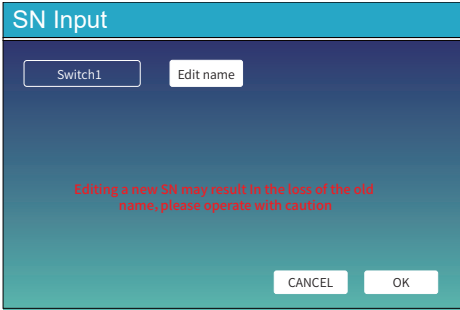

The "SN Input" screen shows a text input field containing "Switch1" and an "Edit name" button. Below the input field, there is a red warning message: "Editing a new SN may result in the loss of the old name, please operate with caution". At the bottom, there are "CANCEL" and "OK" buttons.



The "SN Input" screen shows a text input field containing "switch1" and a "DEL" button. Below the input field, a soft keyboard is displayed with letters a-z. At the bottom, there are "CANCEL" and "OK" buttons.

- Step 1: Click "UP" and "DOWN" buttons on the screen to jump to the smart switch/plug you want to set, and then enable this smart switch/plug.
- Step 2: Click the textbox in the upper right corner on the "Smart devices" page to enter the "SN input" page.
- Step 3: Click the "Edit name" button and then click the "OK" button on the "SN input" page, the soft keyboard will display on the screen for you to type in the desired name of this smart switch/plug.
- Step 4: After completing the input and confirming it is correct, click "OK" to save the setting.

1.4.3 EV charger

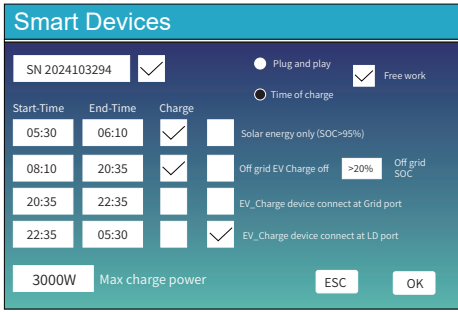

Click on "Smart EV charge" item in the down left corner of "Smart Devices" page to enter the left page. After checking the CheckBox in the upper left corner of this page, you can follow the previous "SN Input" steps to enter the series number of this EV charger which can be found on its label.

Note: The steps to add an EV charger can also be completed through the APP. Please refer to the user manual of EV charger for specific instructions. After adding the EV

charger, please refer to the instructions in the user manual of EV charger to perform channel scanning in order to establish LoRa communication with the smart TX.

Plug and play: The EV charger will operate like a common load, without the need to follow programmable schedule settings.

Time of charge: Control the use of EV charger according to the programmable schedule. 24 hours a day will be divided into four time periods (only the fourth period can pass midnight), and whether to use the EV charger to charge the electric vehicle during each time period can be controlled separately.

Solar energy only (SOC>95%): When the battery SOC is less than 99%, the charging power limit sent by the inverter to the EV charger will be 0. Only when the battery SOC is greater than or equal to 99% will the inverter output a non-zero charging power limit, allowing the charger to start charging. Once the battery SOC drops to $\leq 95\%$, the charging power limit sent by the inverter will return to 0, and the charger will stop charging.

In this mode, "Solar sell" under "System work mode" must be enabled simultaneously to ensure proper operation.

Free work: The AC power output from the inverter module (from solar power and battery discharging power) and the AC power input from the bypass circuit can both be used to power the EV charger.

Off grid EV Charge off: When the hybrid inverter switches to off-grid mode and the SOC of the battery isn't higher than the set value of "Off grid SOC", the EV charger will be automatically turned off.

Off grid SOC: When the hybrid inverter switches to off-grid mode, the EV charger will keep operating if the SOC of the battery is higher than this set value.

EV_charge device connect at Grid port: The EV charger is connected on the Grid port side of the hybrid inverter.

EV_charge device connect at LD port: The EV charger is connected on the Load port side of the hybrid inverter.

Max charge power: The maximum charging power allowed in both "Plug and play" mode and "Time of charge" mode. Range: 0-22000W. In LoRa control mode, the EV charger can only operate normally after receiving this value set by the hybrid inverter.

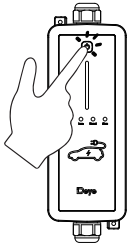

Press and hold the button for at least 1 second until the LED strip turns purple to enter channel scanning mode. After successful channel scan, the LoRa indicator blinks once per second.

Click the link below to download the user manual of the EV charger: "<https://deyeinverter.com/download/product-manual/?tag=54,57>".

1.4.4 Smart CT

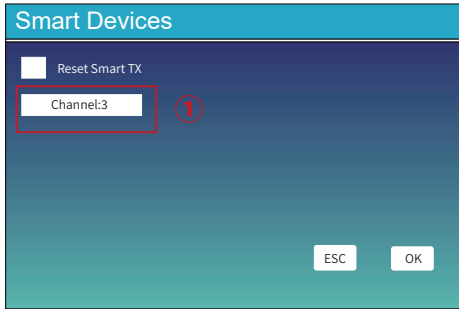

Click on "Smart TX" item in the down right corner of "Smart Devices" page to enter the left page.

Reset Smart TX: Restore factory settings, including restoring the communication channel to the factory default channel and clearing the bound sub device information. Click the zone 1 and press the "UP" and "DOWN" button on the inverter's panel to change the communication channel (frequency) as you desired, this operation can also be conducted on the APP and website of the cloud platform.

Kind reminder: When adjusting the LoRa communication channel of a smart TX, all other smart devices that are communicating with it normally will automatically follow and adjust their own LoRa communication channels accordingly.

2. Detail page of smart devices

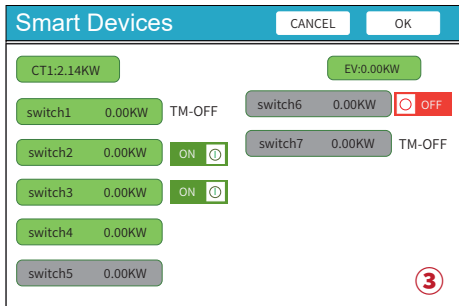
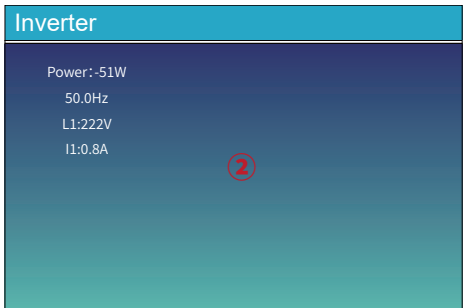
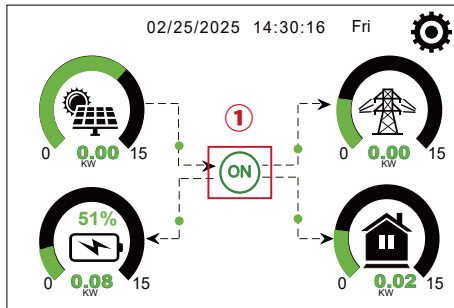

This is the detailed operational information page for smart devices. When the LCD is on the inverter details page, pressing the UP and DOWN buttons on the inverter panel will turn the LCD to this page. On the current page, you can see the working status of all smart CTs, EV charger, and smart switches/plugs connected to this inverter, smart switches/plugs in manual mode can be controlled the ON/OFF status through the ON/OFF button on the current page.

