



Balcony Energy Storage System

SUN-BK60-2.0KWH-EU-AM2

SUN-BK80-2.0KWH-EU-AM2

SUN-BK100-2.0KWH-EU-AM2

User Manual

Contents

1. Product Introduction	01
2. Packing List	01
3. Safety Precautions	02
3.1 Preparations before Connecting	03
3.2 Safety Precautions during Use	03
4. Product Appearance	04
5. Instructions for Connections of the Product	05
5.1 LOAD port	05
5.2 PV port for DC input	06
5.3 Connection of Grid port	08
5.4 CT Port for AC input	09
5.5 BAT Port for DC input	10
5.6 USB Port for DC Output	10
5.7 System Diagram	11
5.8 System Working Mode	12
5.9 Power On/Off	12
5.10 Introduction to Display Screen Icons	13
5.11 Application Scenarios	14
6. Using the APP	14
6.1 Login	15
6.2 Create A Plant	16
6.3 Add data logger	16
6.4 Configuration of the Network	17
6.5 Create smart devices	21
6.6 Commissioning via APP	22
7. Application modes	39
8. Use of the Extender Battery Module	45
8.1 Parameters and Specifications of the Extender Battery module	45
8.2 Connection Method for AE-F2.0	45
8.3 Precautions during Use	46
8. FAQ	46
9. Common Faults and Troubleshooting Methods	47
10. After-sales Service	55
11. Disposal	55
12. EU Declaration of Conformity	56
13. Parameters and Specifications	57







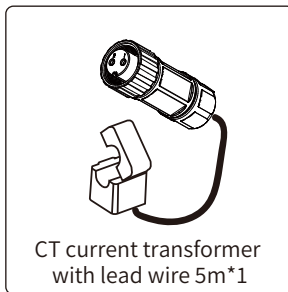
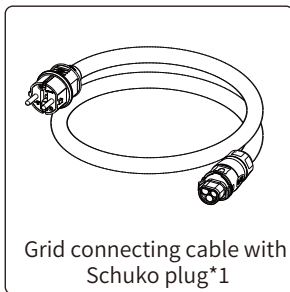
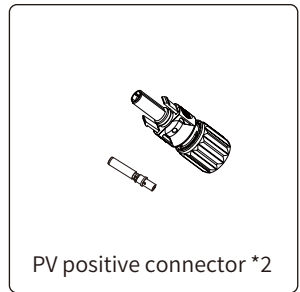
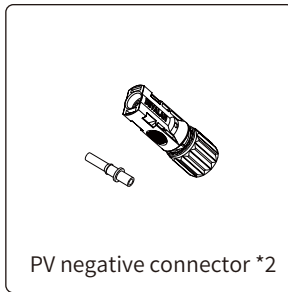
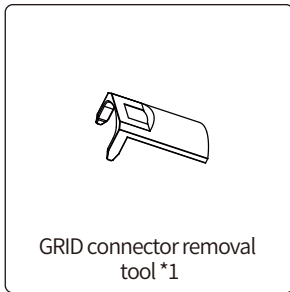
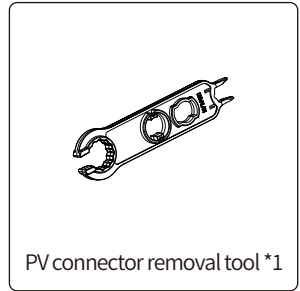
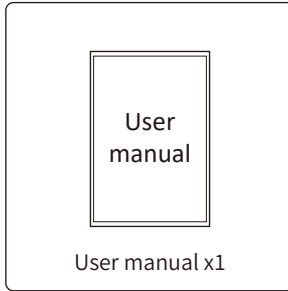
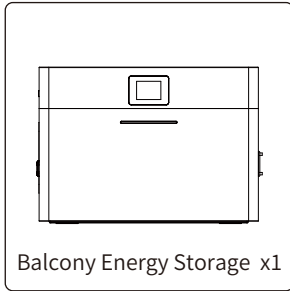







1. Product Introduction

The DEYE 1000W/2000Wh Balcony Energy Storage SUN-BK60/80/100-2.0KWH-EU-AM2(Hereinafter referred to as ESS) features built-in lithium iron phosphate battery cells and various functions including AC grid-connected charging/ discharging, off-grid power supply (UPS) applications, direct digital devices charging via USB ports, 1600W PV power charging, and battery capacity expansion up to 10kWh. Real-time monitoring of the power status is possible either locally via a touch screen, or remotely via an app. It is an optimal solution for balcony PV energy storage and portable outdoor power supplies.

2. Packing List



3. Safety Precautions

Label	Description
	Caution, risk of electric shock symbol indicates important safety instructions, which if not correctly followed, could result in electric shock.
	The DC input terminals of the inverter must not be grounded.
	Surface high temperature, Please do not touch the inverter case.
	The AC and DC circuits must be disconnected separately, and the maintenance personnel must wait for 5 minutes before they are completely powered off before they can start working.
	CE mark of conformity
	Please read the instructions carefully before use.
	Symbol for the marking of electrical and electronics devices according to Directive 2002/96/EC. Indicates that the device, accessories and the packaging must not be disposed as unsorted municipal waste and must be collected separately at the end of the usage. Please follow Local Ordinances or Regulations for disposal or contact an authorized representative of the manufacturer for information concerning the decommissioning of equipment.
	Do not run and chase.
	Do not place near open fire or incinerate. Do not use near heaters or hot temperature.
	Do not touch with your palm.
	Do not tread.
	Indicates that this product is recyclable.
	Li-ion Battery.
	Attention! The risk of explosion.

-
- This chapter contains important safety and operating instructions. Read and keep this manual for future reference.
 - Before using the inverter, please read the instructions and warning signs of the battery and corresponding sections in the instruction manual.
 - Do not disassemble the inverter. If you need maintenance or repair, take it to a professional service center.
 - Improper reassembly may result in electric shock or fire.
 - To reduce risk of electric shock, disconnect all wires before attempting any maintenance or cleaning. Turning off the unit will not reduce this risk.
 - Caution: Only qualified personnel can install this device with battery.
 - Never charge a frozen battery.
 - For optimum operation of this inverter, please follow required specification to select appropriate cable size. It is very important to correctly operate this inverter.
 - Be very cautious when working with metal tools on or around batteries. Dropping a tool may cause a spark or short circuit in batteries or other electrical parts, even cause an explosion.
 - Please strictly follow installation procedure when you want to disconnect AC or DC terminals. Please refer to "Installation" section of this manual for the details.
 - Grounding instructions - this inverter should be connected to a permanent grounded wiring system. Be sure to comply with local requirements and regulation to install this inverter.
 - Never cause AC output and DC input short circuited. Do not connect to the mains when DC input short circuits.

3.1 Preparations before Connecting

1. After unpacking, please check the battery and the packing list first. If the battery is damaged or missing any parts, please contact the local retailer.
2. Before installation, make sure to cut off the grid power supply and ensure the battery is turned off.
3. The connections must be correct, and there must be no short circuiting with external devices.
4. Keep away from any ignition sources.
5. Do not use parts or accessories that are not provided by the official supplier.
6. Do not stack heavy objects on top of the battery.

3.2 Safety Precautions during Use

1. To move or repair the battery, please disconnect the power supply and fully turn it off first.
2. Do not connect the battery with other batteries of different models.
3. Do not remove any part of the battery.
4. In case of a fire, only liquid fire extinguishers should be used; dry fire extinguishers are prohibited.
5. If the enclosure is tested without equipment inside, detailed requirements shall be indicated by the enclosure manufacturer in his instructions for the arrangement and spacing of hazardous parts or parts which might be affected by the penetration of foreign objects or water. The manufacturer of the final assembly shall ensure that after the electrical equipment is enclosed, the enclosure meets the declared degree of protection of the final product.
6. Only operate this device on a steady, dry surface.

4. Product Appearance

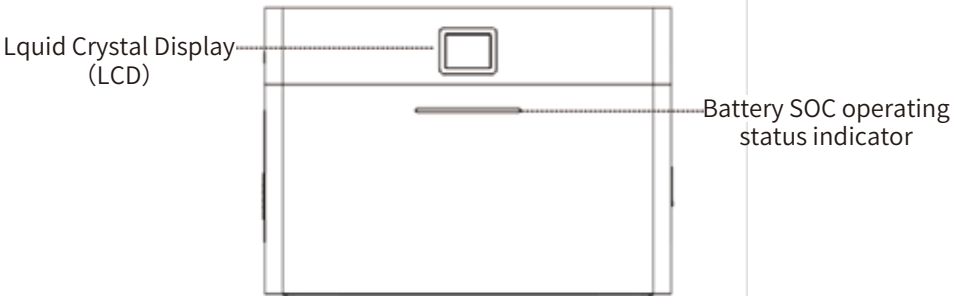
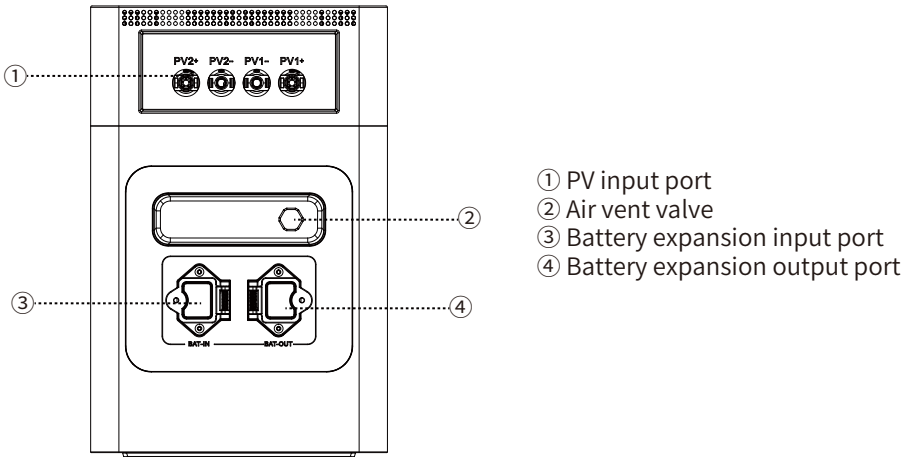
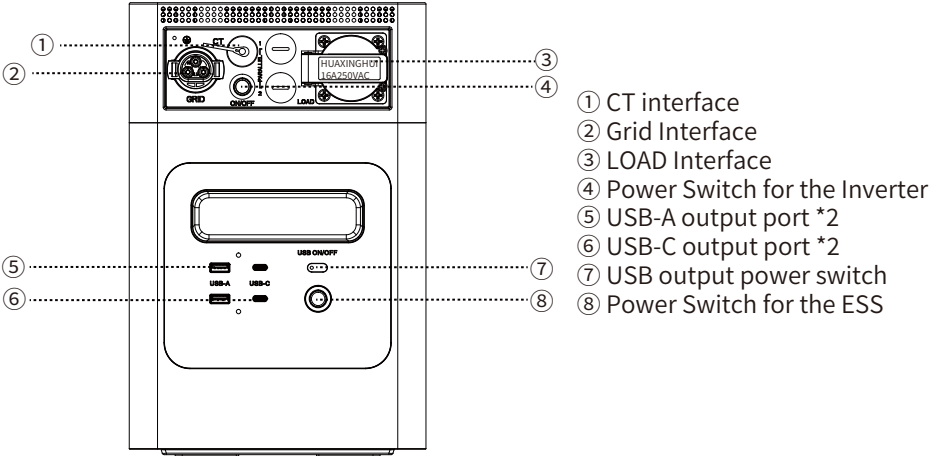

5. Instructions for Connections of the Product



Warning:

- Do not place the equipment near heat sources or fire sources, such as smoke, heaters, or other heating devices. Overheat may damage the equipment or cause a fire.
- Do not install the equipment in a position that may be submerged in water.
- Do not install the equipment in an area with strong vibration, noise, or electromagnetic interference.

5.1 LOAD port

1. First, make sure that the battery is turned off.
2. Open the protective cover of the load interface, insert the plug of the appliance to be used into the interface, make sure the connection is tight.
3. After confirming the correct connections, press the Power Switch for the ESS. Wait for the indicator lights to display. Press the Power Switch for the Inverter. Wait for the LCD screen to light up. Then, the device will run a diagnostic test. The system is running normally if there is no faults or alarm.
4. Check the screen display, if the display is normal, the connection is successful and power is successfully supplied to the appliance.

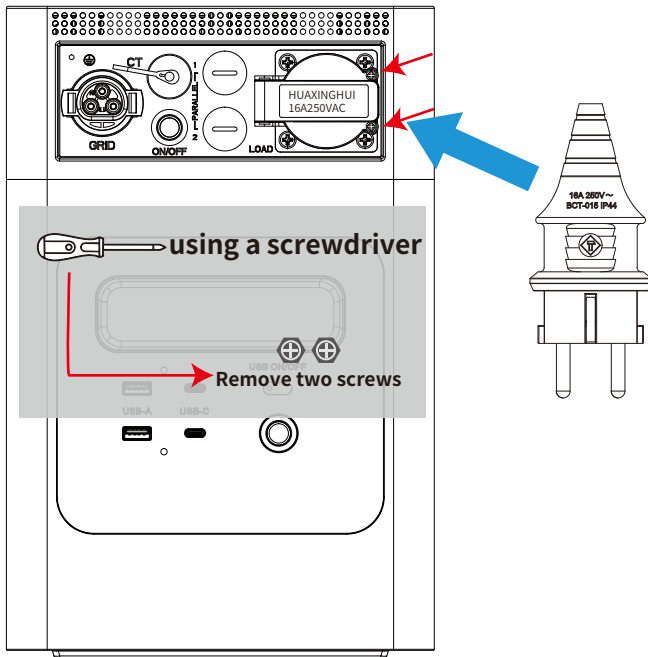

5.2 PV port for DC input

Before charging the battery, make sure the PV port is correctly connected to the PV power source. Turn on the main power switch of the battery pack, then the inverter power switch. The LCD screen will light up, and the battery will run a diagnostic test. If there is no faults or alarm, the system is operating normally, and the setup is successful.

Please refer to the following parameters when selecting a suitable PV power source:

1. The max. open-circuit voltage (Voc) of the PV module should not exceed 60V (upper limit of the inverter).
2. The min. open-circuit voltage (Voc) of the PV module should be higher than 25V (min. Startup voltage of the inverter).
3. Input voltage range: 20V - 60V.

Inverter model	SUN-BK60-2.0KWH-EU-AM2	SUN-BK80-2.0KWH-EU-AM2	SUN-BK100-2.0KWH-EU-AM2
PV Input Voltage	25V (25V-60V)		
PV Array MPPT Voltage Range	20V-55V		
No. of MPP Trackers	2		
No. of Strings per MPP Tracker	1+1		

5.2.1 Connections of PV Modules:

1. Turn off the main grid power switch (AC).
2. Install the PV input connector onto the inverter.

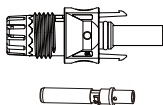

DC+ male connector

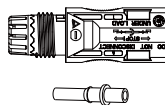

DC- female connector



Safety Instructions:

Please use DC cables that meet the requirements for PV use.

Type of Cable	Cross Section (mm ²)	
	Range	Recommended Value
Specialized PV DC cable (model: PV1-F)	2.5-4.0(12-10AWG)	2.5(12AWG)

Common Cable Specifications

The steps to install the DC connectors are as follows:

- a) Strip the outer sheath off the DC wire by approximately 7 millimeters, then remove the connector's locking nut.

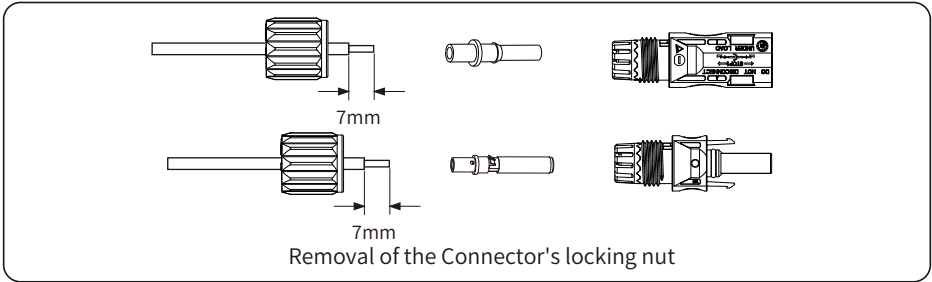

- b) Use a crimping tool to crimp the metal terminal.

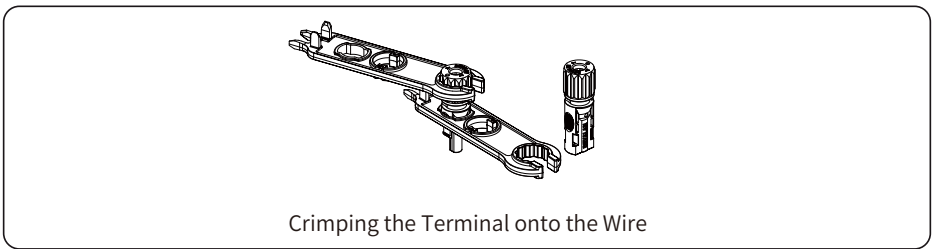

- c) Insert the crimped terminal through the locking nut into the top of the connector, then tighten the locking nut back onto the connector.

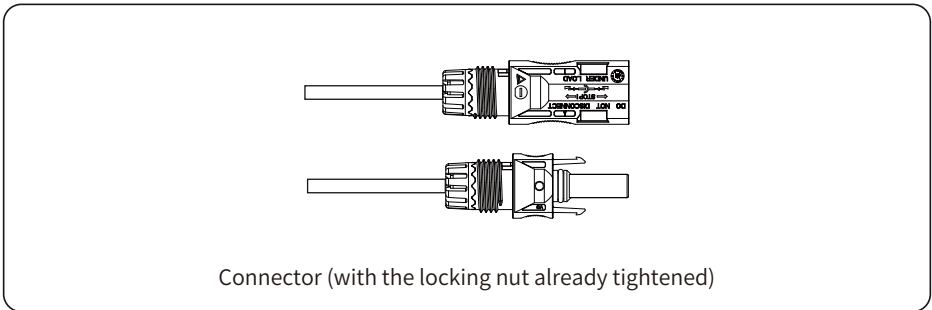

- d) Finally, insert the DC connectors into the positive/ negative input ends of the inverter.

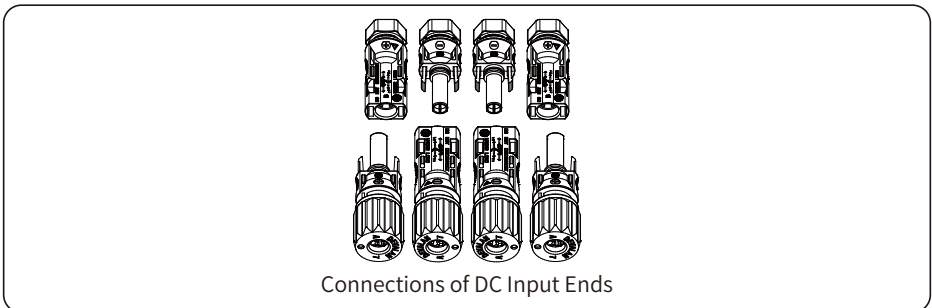

5.3 Connection of Grid port

After the DC connectors have been connected, do not close the DC switch (leaving it open-circuit).



Warning:

It is prohibited to use a single circuit breaker for multiple inverters and to connect any load between adjacent inverter circuit breakers.

Model	Cross-sectional Area of the Cable	Circuit Breaker	AWG	Maximum Cable Length
SUN-BK60/80/100-2.0KWH-EU-AM2	1.5mm	20A/400V	14	External cable (L+N+PE)20m

Cable Information

The AC output connector is divided into three parts: a socket, a sleeve, a sealing ring, and a locking nut. The connection steps are as follows:

Step 1: Remove the sealing ring and the sleeve from the AC connector in turn.

Step 2: As shown in Figure 5.7, separate the sleeve from the socket. There are two locking holes on the connector body. Press the locking valve inward to separate the socket and the sleeve.

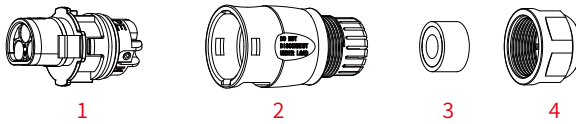

1. socket; 2. Sleeve; 3. Sealing ring; 4. locking nut;
AC Connector Structure

Step 3: To prepare the AC cable, use a wire stripper to strip off the outer sheath for about 40mm and the insulation of each conductor for about 8-15 mm, as shown in the figure below.

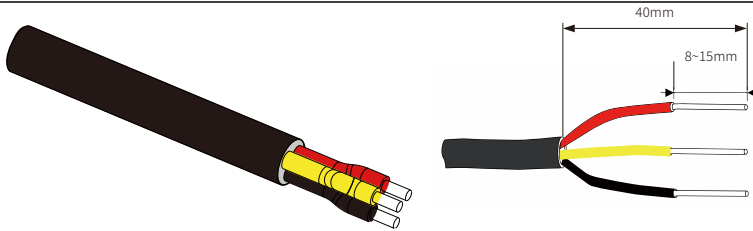

Stripping off the Outer sheath and the insulation of each conductor of the AC cable.



Warning:

Please pay attention to differentiate between the L, N, and PE conductors of the AC cable.

Step 4: Run the L, N, and PE conductors of the cable through the locking nut, the sealing ring, and the sleeve. Pay attention to follow that particular order and the orientation of the parts.

Step 5: Use a hexagonal screwdriver to loosen the socket bolts, then insert each conductor into the corresponding hole, and tighten all bolts. The orientation of the conductors in the AC connector is shown in the diagram below.

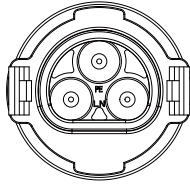

The orientation of the conductors for the AC Connector

Step 6: Slide the sealing ring and the sleeve along the conductors until the sleeve clicks into the socket. Make sure the sealing ring is tightly fit into the sleeve around the conductors and then tighten the locking bolt. The AC connector is ready for use.

Step 7: Plug in the AC connector into the AC input port of the battery. Prior to charging the battery, ensure the GRID port is correctly connected to the mains power supply. Start by turning on the battery pack power switch, then turn on the inverter power switch. The LCD screen will light up, indicating that the device has started running the diagnostic test. If there is no faults or alarm, the system is operating normally, and the battery can be charged through the mains power supply.

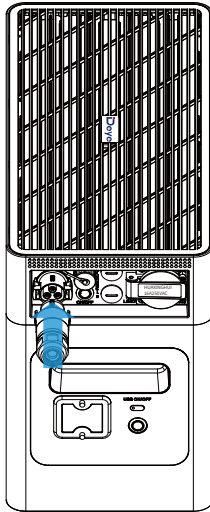

Connection for the AC Input port

5.4 CT Port for AC input

If you are currently running the ESS and wish to activate the anti-backflow function, please turn off the inverter's AC and DC switches, and wait for 5 minutes until the ESS is completely discharged. Then connect the current sensor output to the CT port on the ESS. Make sure the connection is secured, and clamp the current sensor onto the L phase of the mains power supply. In order to provide more insights into the use of the built-in anti-backflow function of the ESS, we have provided a wiring diagram as shown below. The red wire connected to the grid supply represents the L phase, the blue wire represents the neutral N phase, and the green-yellow wire represents the ground wire (PE). We recommend installing an AC switch between the ESS AC input port and the grid supply. The specifications of the AC switch should be determined based on the load capacity.

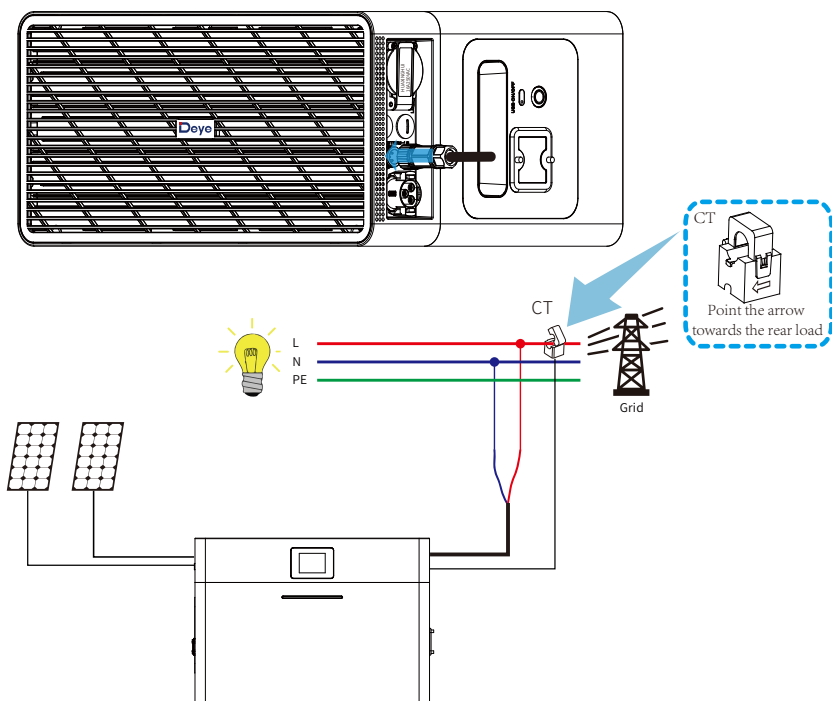

5.5 BAT Port for DC input

The balcony energy storage system is equipped with an expansion interface to support up to 4 battery packs in parallel.

When multiple battery modules in parallel are used as an energy storage system. Use a series connection cable to connect the BATOUT port of the first battery module and the BATIN port of the next battery module, and so on and so forth until the BATIN port of the last battery module is connected. Parallel operation of up to five battery modules is possible.

5.6 USB Port for DC Output

Turn on the battery pack power switch, the LED light will lit up. Then turn on the inverter power switch, and short press the USB ON/OFF button to activate the DC output. At this point, the USB-A/USB-C ports will start functioning, allowing users to connect devices such as mobile phones.

Note: After the DC output is actively discharging into a load, the battery will not shut down automatically. You need to manually turn off the DC output.

If there is no load connected to the DC output within ten minutes, the battery will automatically shut down.

If water enters the USB port, use a dry tissue to absorb the water. After drying it, the device can be used normally. Failure to do so may cause it to malfunction but will not damage the USB port.



Warning:

Do not insert other chargers into the USB port, as the port could be damaged.

5.7 System Diagram

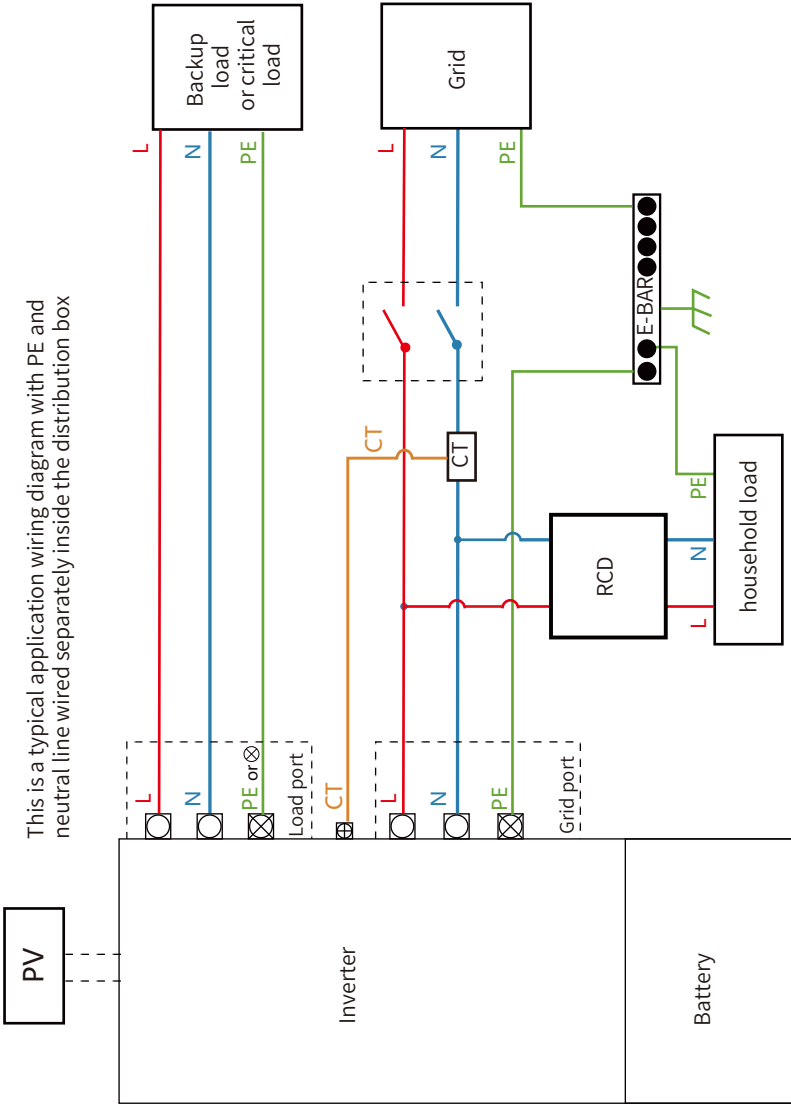

Warning:

A type 2 SPD needs to be added to the grid side of ESS. Without SPD, the working mode of ESS is limited to the following scenarios: (1) Operating in off-grid mode; (2) Operating in on-grid mode without load, power taken from the grid can only be used to charge the battery.



5.8 System Working Mode

Grid-connected mode: After the grid port is connected, the battery module and the connected PV power source can supply energy to the grid. The energy transfer logic can be configured, and it is also possible to set the grid supply and the connected PV power source to charge the battery module.



Off-grid mode: When the grid port is not connected, the inverter automatically switches to the off-grid mode and supplies the connected load with the PV power source and the battery module. It prioritizes using PV power, supplementing with the battery module when needed. Excess PV power, when available, is used to charge the battery module.



5.9 Power On/Off

(1) Power on

Press the power button of battery module, and the LED indicator lights up. Then press the inverter power button to turn on the inverter, and the LCD screen lights up. Short press the USB ON/OFF button to activate the USB DC output port. The LCD of this ESS will automatically dim after 2 minutes of inactivity and light up again after any operation or alarm occurs.

(2) Power off

When the battery module has been powered on, press the power button of inverter module to power off inverter module, then press the USB ON/OFF button of battery module to power off the USB terminals, and finally press the power button of battery module to power off it.

Note: *The USB terminals of battery module have a default 5 minutes standby time after being turned on. If there is no DC load connected within 5 minutes, the USB terminals will automatically shut down, and the standby time can be set in the APP.

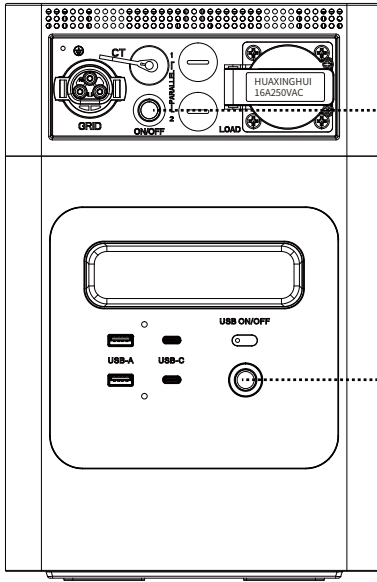

Power button of inverter

Power button of battery module

5.10 Introduction to Display Screen Icons

Date and time 2025-01-08 11:27:16 Wed
 Output power of USB 0 W
 PV generation power 2200 W
 Module quantity and SOC of battery 0/91%
 UPS Power 0 W
 Bluetooth connection status
 WiFi connection status
 Grids 4000 W
 Fault code F13
 load power 0 W

5.11 Application Scenarios

The battery offers solutions for both household energy storage systems and portable outdoor power supplies.

The household energy storage systems can either come with PV charging or without it.

For the system with PV charging, the UPS port is connected to the grid, and the PV port is connected to the PV power source. The battery functions as a hybrid energy storage system.

Please refer to Sections 7.2 and 7.3 for connection instructions.

For the system without PV charging, the UPS port is connected to the grid, and the battery is an energy storage device for a small-scale PCS. See Section 7.2 for connection instructions.

When the battery is used as a portable outdoor power supply, it provides power to digital devices and appliances. PV panels can be connected to the battery for outdoor use as well, should it be necessary. Refer to Section 6.1 for connection instructions for the above uses.

6. Using the APP

You can control and monitor the battery through the Deyecloud APP or the website www.deyecloud.com. Download the Deyecloud APP by scanning the QR code below.



Deye Cloud

All in one, Efficiency



Scan QR code to download APP



6.1 Login

On the login page, you can choose to log in with email, phone number, or username. Enter the corresponding account information and click "Login".

Note: Only accounts registered with usernames in the old version support logging in with usernames.

Step 1: Phone number login — log in with password or verification code.

Step 2: Click on the icon at the bottom of the page to switch to email login or username login.

Step 3: Check [I have read and agreed to the Service Agreement/Privacy Policy] and click [Login].

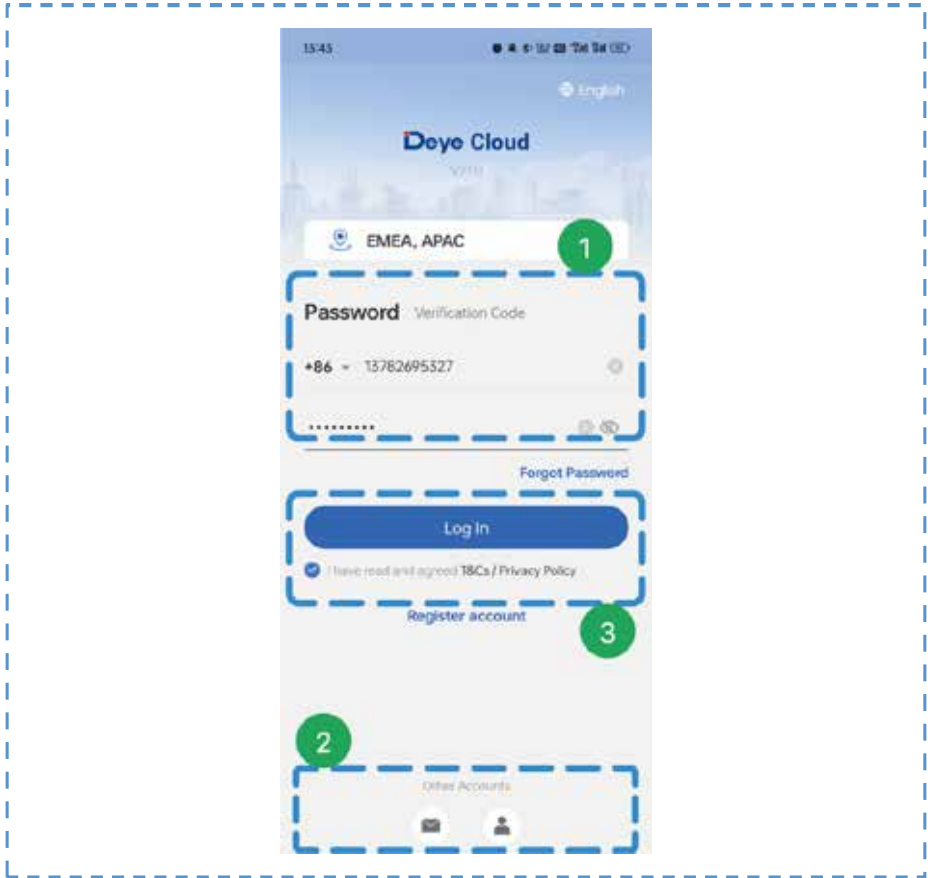

6.2 Create A Plant

Step 1: Click on the top right corner of the plant page and select [Create A Plant].

Step 2: After filling in the relevant information about the plant, click [Confirm].

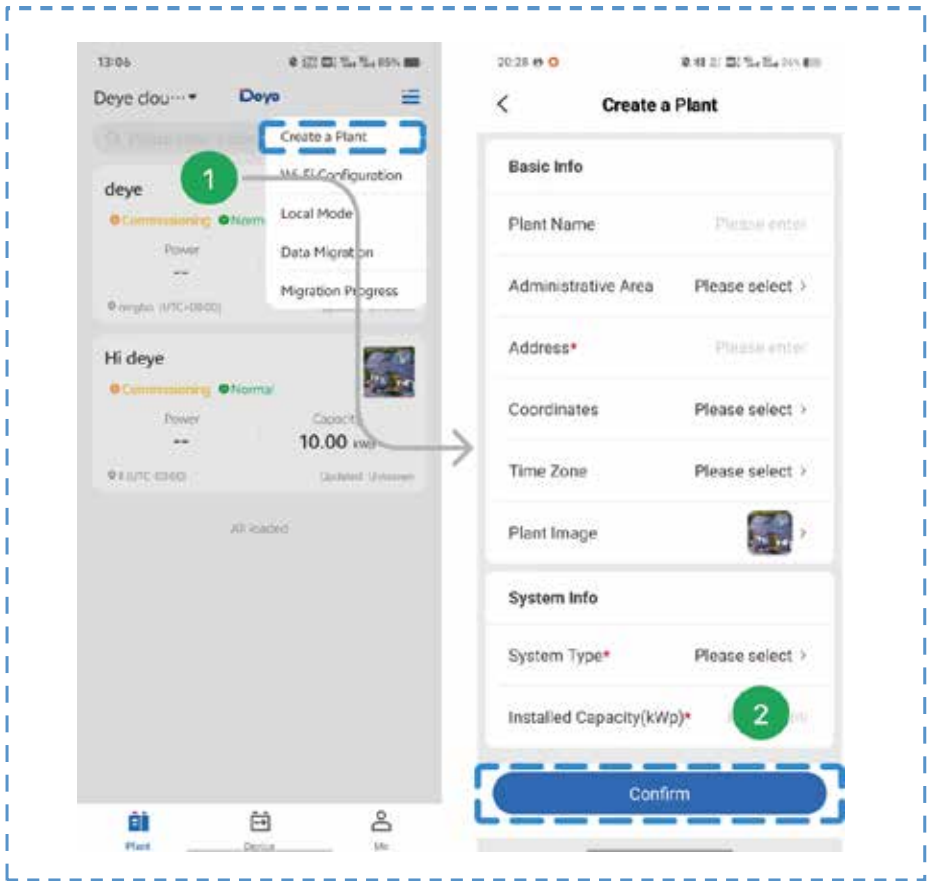

Note: Please select the correct grid connection type. For string inverters and micro-inverters, select the grid connection system; for energy storage inverters, choose the energy storage system.

6.3 Add data logger

Method 1: After successfully creating the plant, click [Add Now] directly in the pop-up window.

Method 2: Go to the plant details page, click the drop-down menu in the top right corner, and then click [Add Device].

Note: There are two ways to input the serial number - scanning the QR code or manually entering the serial number.

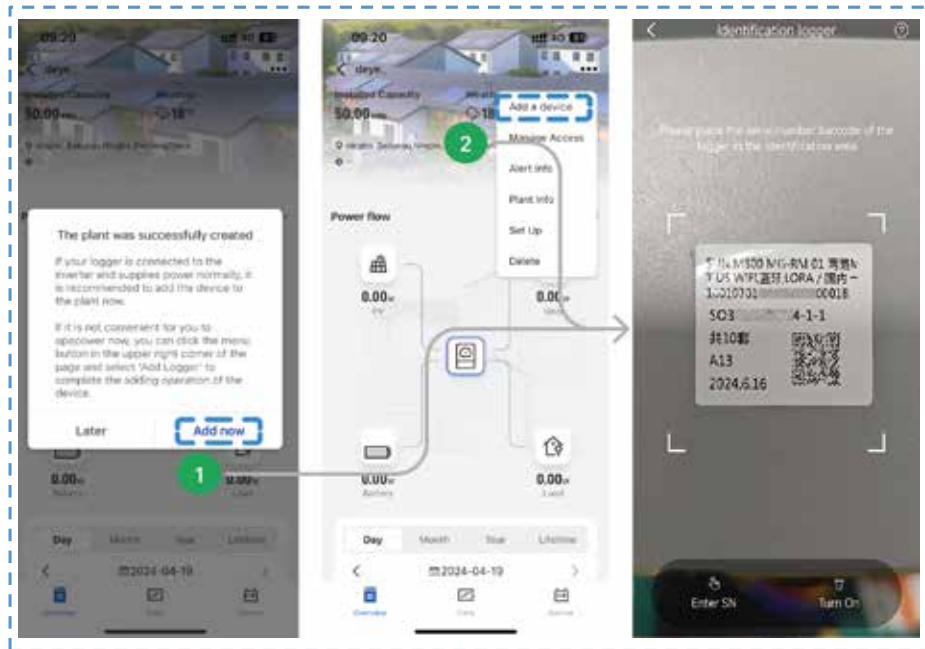

6.4 Configuration of the Network

After successfully adding the collector, please configure the Wi-Fi network for the collector to ensure the system operates correctly.

Method I: Network Configuration via Bluetooth

Step 1: Go to the configuration page for network configuration. There are two ways to access the configuration page:

- ① : Click [Add Device] under the plant list.
- ② : Click [Wi-Fi Configuration] under the “plant - device list - collector” options.

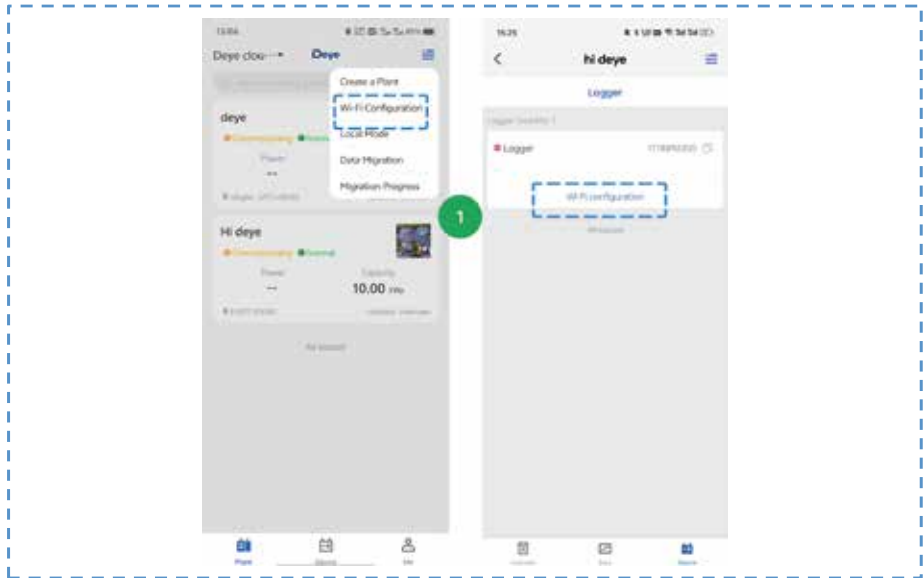

Step 2: Access the Bluetooth search interface by default. From the list of discovered devices, select the required SN.

Step 3: The system will automatically retrieve the current network connected to the phone. You can also manually modify it. After entering the Wi-Fi password, click on [Next].

Step 4: After the network configuration is completed, you can enter a personalized name. Finally, click on [Finish] to complete the configuration.

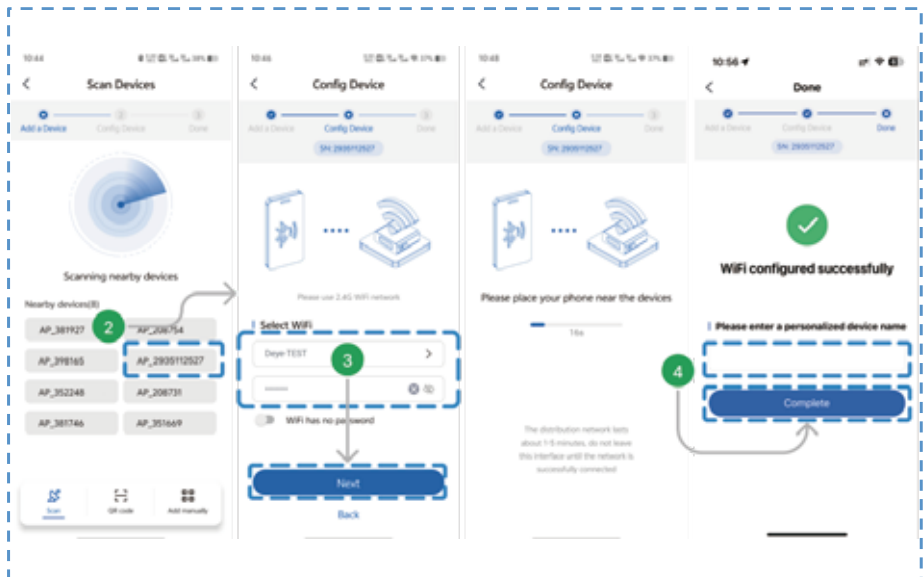

Method 2: Network Configuration via Wi-Fi

For devices that do not support network configuration via Bluetooth, the network configuration can be done by scanning the QR code or entering the collector SN.

Step 1: Click [Scan to Add] or [Manually Add] to add the device.

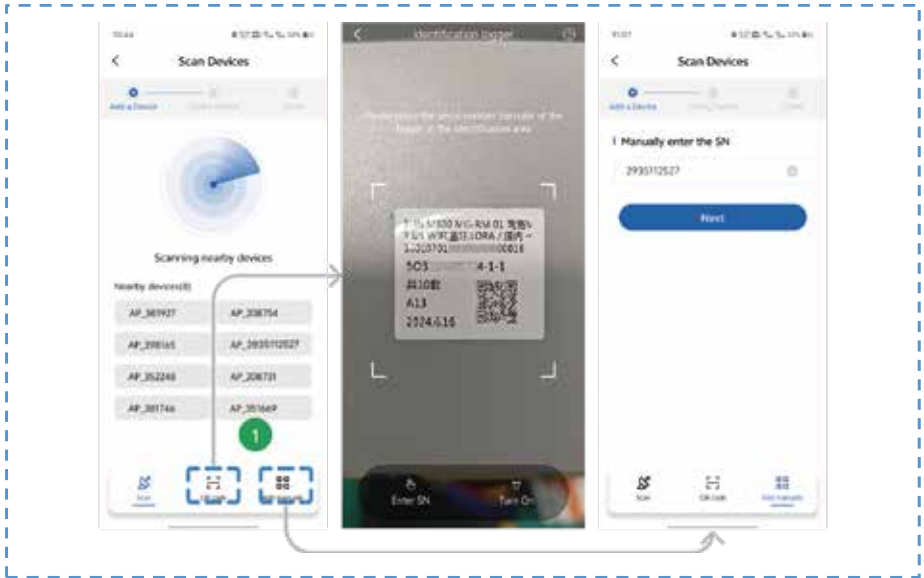

Step 2: The system will automatically retrieve the current network connected to the phone. You can also manually modify it. After entering the Wi-Fi password, click on [Next].

Step 3: Wait for the system to perform Wi-Fi network detection.

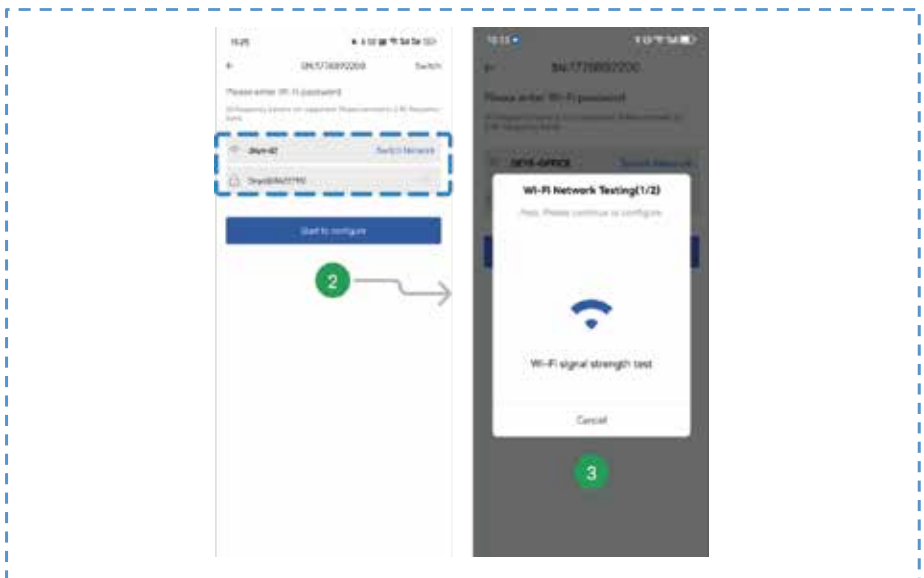

Step 4: click [Connect] to skip to the WLAN page and configure the collector.
Step 5: Select WLAN (AP+SN) prompted by the system and enter the password.
Step 6: Click [←] to return to the APP after the successful connection.

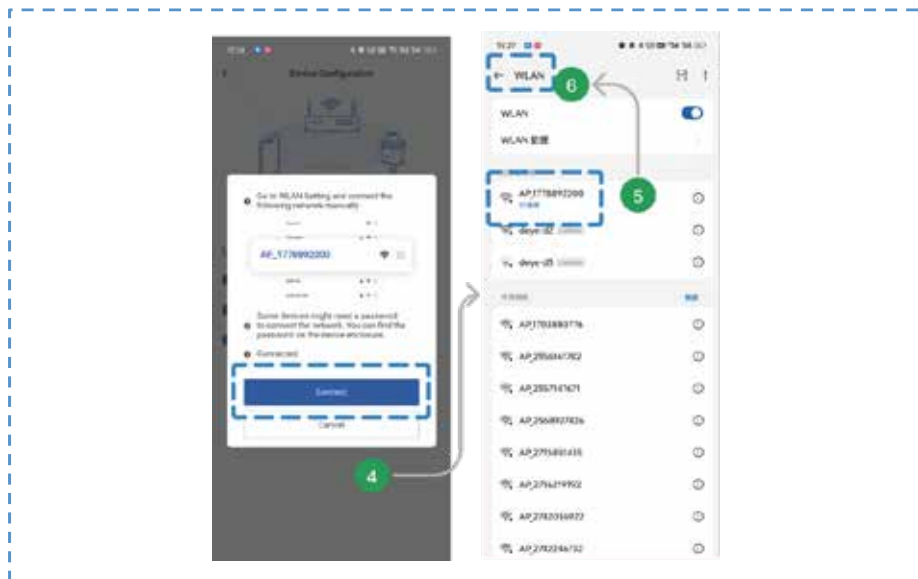

Step 7: Connect the device and wait for the configuration process, including Configuring, Restarting, and Completing Verification.
Step 8: After the "Configuration Succeeded" page is displayed, click [Complete] to close the page and complete the network configuration.

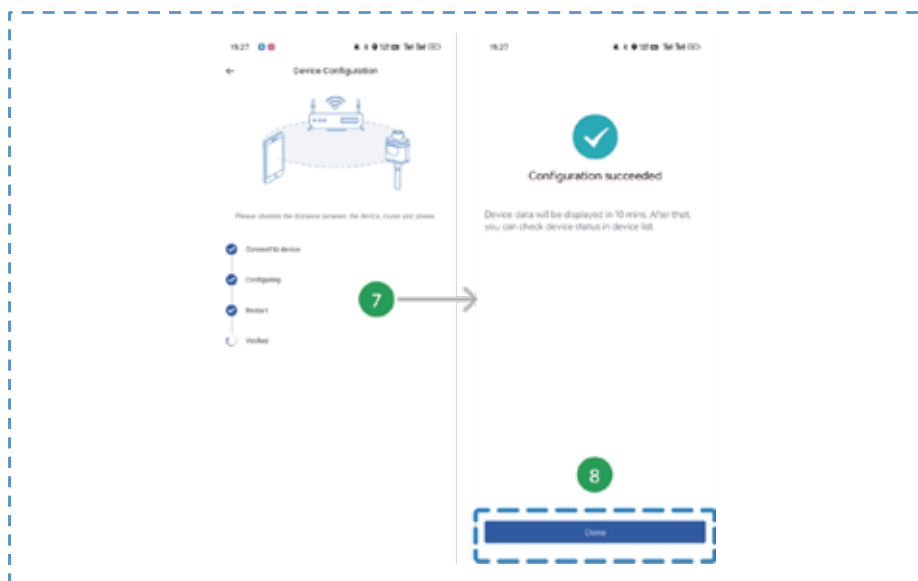

6.5 Create smart devices

Step 1: After Network configuration is done, click the "Device" icon on the lower right corner of plant page to enter the "Device" page.

Step 2: Click the blue "Smart Device" icon just below the Micro Storage System to bind smart devices to it.

Step 3: Click the "+" icon on the lower right corner of this page.

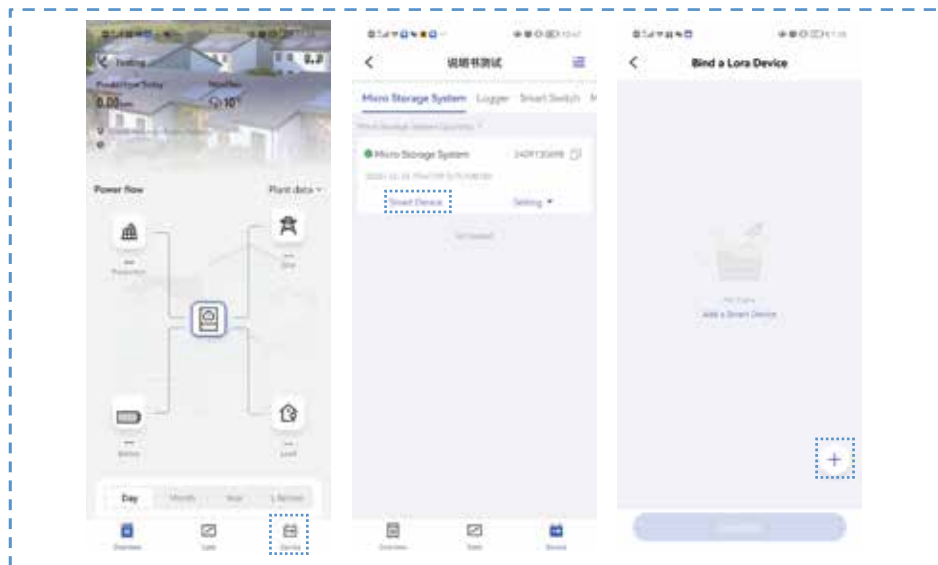

Step 4: To scan the SN QR code of the smart device or type its SN manually.

Step 5: Choose which type of smart device it is.

Step 6: After choosing the type of smart device, click the "Confirm" button on the bottom to surely bind this smart device to the Micro Storage System.

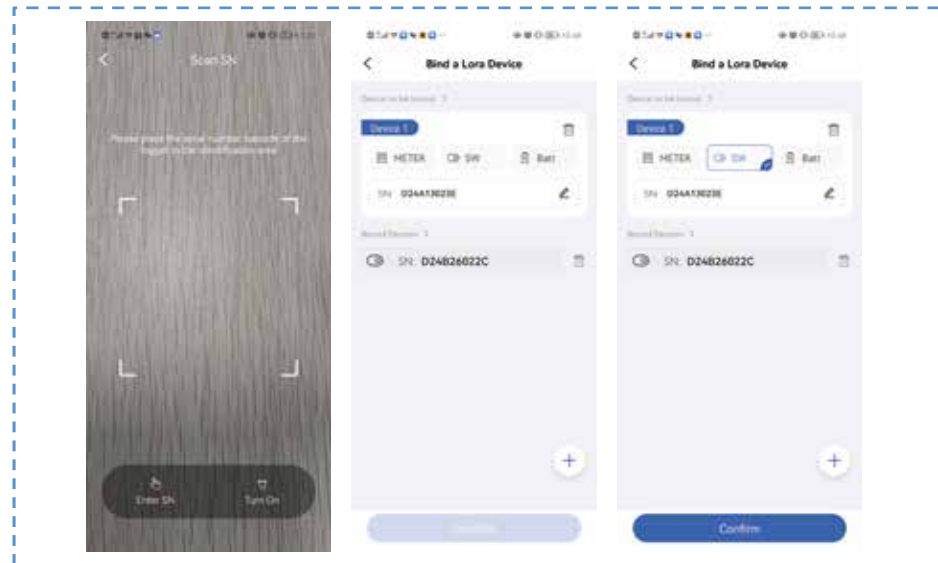

6.6 Commissioning via APP

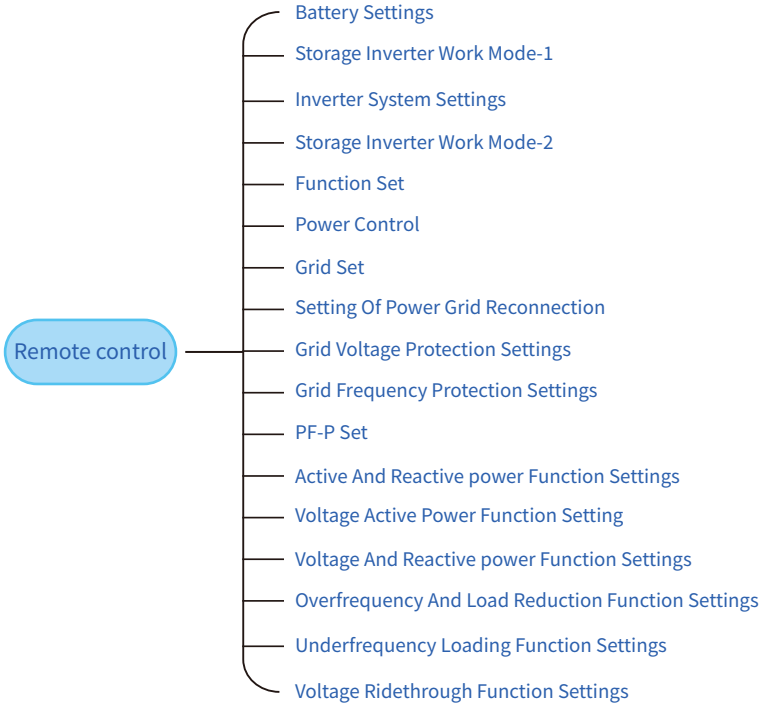

Optional parameter settings:

1. First, click on the "Read" button for the functional item
2. Switch options and click on "Confirm" in the upper right corner of the pop-up window
3. Further modify the Setup of the functional item

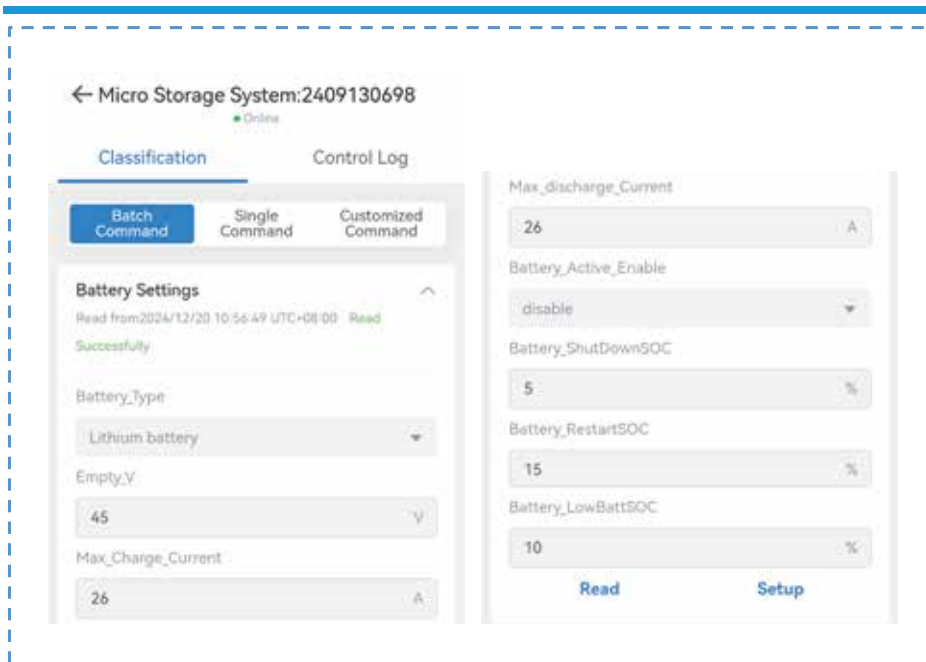

Battery Setting

Battery_Type:

Range: Lead-Battery/Lithium Battery/No Battery.Note: Balcony energy storage(Choose the "Lithium Battery")

Empty_V:

Range:0.01-60.00.The voltage of battery when it is discharging to empty status.

Max_Charge_Current:

Range:0.01~26.00.The upper limit of charging current allowed.

Max_Discharge_Current:

Range:0.01~26.00.The upper limit of discharging current allowed.

Battery_Active_Enable:

Disable/Enable.Activate the over discharged batteries with a small charging current.

Battery_ShutDownSOC:

Range:0~100.When the inverter operates in off-grid mode and the battery SOC drops to this set value, the low SOC protection is triggered, the inverter will shut down its DC/AC inverter module to stop outputting AC power.

Max_Discharge_Current:

Range:0~100.When the inverter operates in off-grid mode and the battery SOC restores to this set value, the inverter will restart its DC/AC inverter module to output AC power again.

Battery_LowBattSOC:

Range:0~100.When the inverter operates in on-grid mode and the battery SOC drops to this set value, this low SOC protection will be triggered, the inverter will stop discharging the battery to maintain the .battery SOC not lower than this set value.

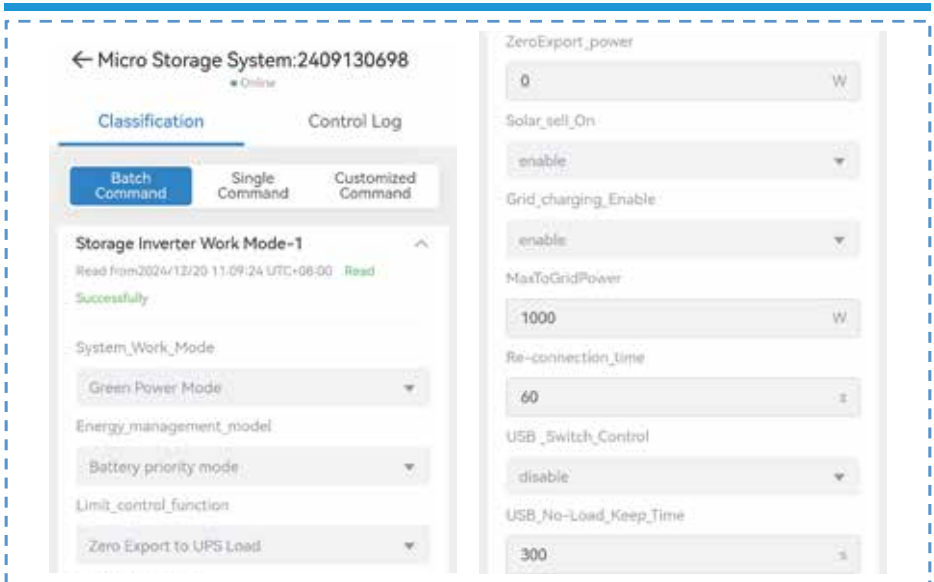

Storage Inverter Work Mode-1

System_Work_Mode:

Green Power Mode: Solar and battery storage energy will mainly be consumed locally by user, but it is also allowed to sell electricity to the grid under specific circumstances.

Full Charge Mode: Before portable use, fully charge the battery with solar or grid power.

Customized Mode: Charging or discharging based on the programmable settings of TOU function.

Energy_management_model:

Battery priority mode: PV power will be prioritized for charging battery.

Load first mode: PV power will be prioritized for supplying power to loads.

Limit_control_function:

Sell First: It is allowed to feed power into the grid.

Zero Export to UPS Load: The AC output power of inverter module will only be used to supply the backup loads on the load port of this ESS system.

Zero Export to CT: Use an external CT to prevent current output from the inverter from flowing into the grid after passing through the external CT.

Zero Export to wireless CT: Use an external CT to prevent current output from the inverter from flowing into the grid after passing through the external wireless CT meter.

ZeroExport_power:

Range: 0-500W. To get this set power from the grid to prevent the feed-in power from inverter to grid due to the measuring error of build-in or external CT.

Solar_sell_On:

Range: Enable/Disable. Whether or not to sell the excess solar power to the grid.

Grid_charging_Enable:

Range: Enable/Disable. To set whether it is allowed to use the grid power to charge the battery or not.

MaxToGridPower:

Range: 0-1000. The upper limit of power allowed to be fed into the grid.

Re-connection_time:

Range: 10-3000. Reconnection time after grid restoration.

USB_Switch_Control:

Range: Enable/Disable. To set whether the power button of USB terminals can control the ON/OFF status of USB terminals or not.

USB_No-Load_Keep_Time:

Range: 300-1800. The USB terminal will be turned off when the idle time reaches this set value.

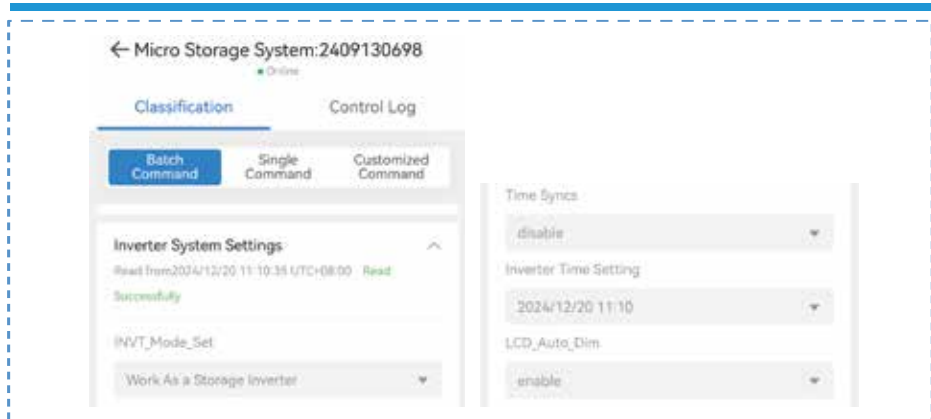

Inverter System Settings

INVT_Mode_Set:

Work As a Microinverter: To work as an on-grid microinverter without energy storage function.
 Work As a Storage Inverter: To work as a micro hybrid inverter with energy storage function.

Time Syncs:

Range: Enable/Disable. After enabling, when the ESS is online, its time will be synchronized with the cloud platform's time.

Inverter Time Setting:

To set the local time for this ESS manually.

LCD_Auto_Dim:

Range: Enable/Disable. After enabling this function, the LCD display of this ESS will automatically dim after 2 minutes of inactivity.

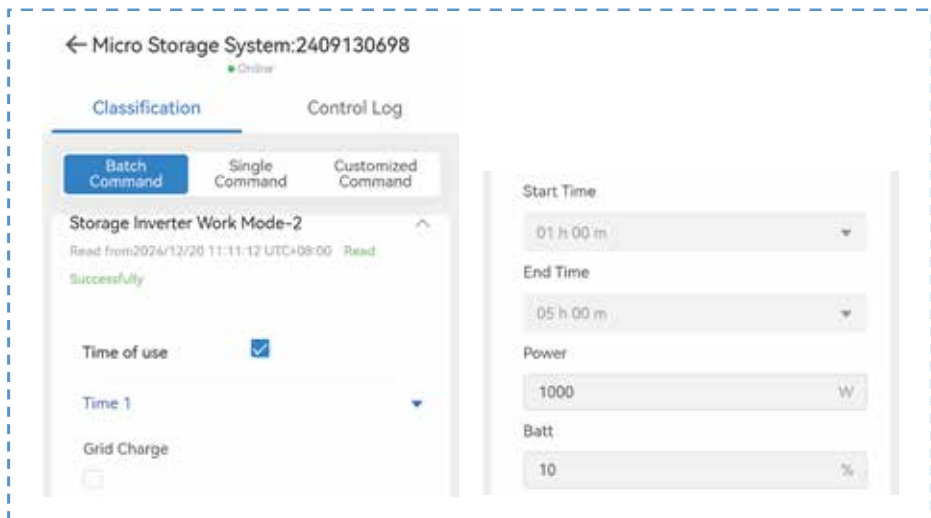

Storage Inverter Work Mode-2

Time of use:

Manage battery charging and discharging according to a programmable schedule.

Time 1/2/3/4/5/6:

Six programmable time period.

Grid Charge:

To set whether it is allowed to use the grid power to charge the battery or not.

Start Time:

The starting time point of each time period.

End Time:

The ending time point of each time period.

Power:

0-1000W.The upper limit of discharging power of each time period.

Batt:

0-100%.The target SOC of battery during each time period. When the actual SOC of the battery is higher than this set value, the battery can be discharged. When the actual SOC of the battery is lower than this set value, the battery needs to be charged.

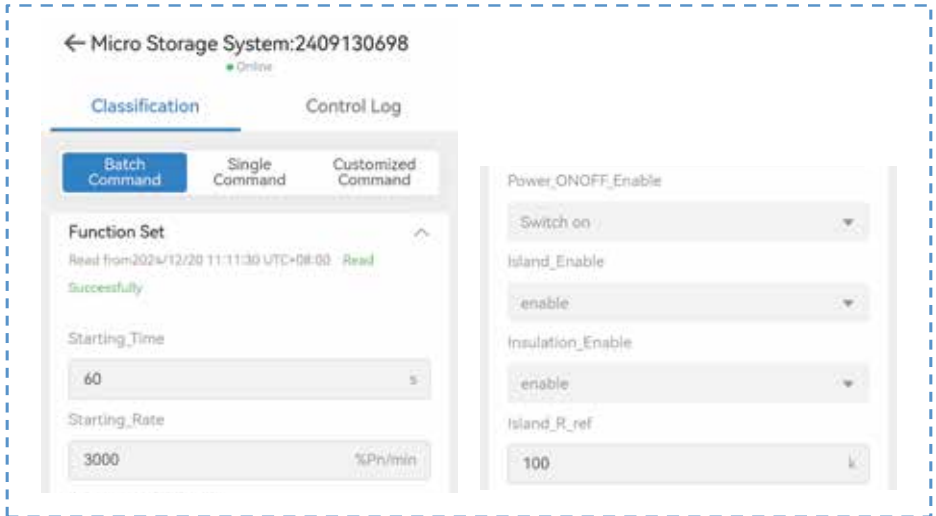

Function Set

Starting_Time:

0-1000.The time required to start the inverter module of this ESS.

Starting_Rate:

0.0-3000.0.The ramp rate percentage based on rated output power.

Power_ONOFF_Enable:

Range:Switch on/Switch off.To power ON/OFF the inverter module of this ESS remotely via APP.

Island_Enable:

Range: Enable/Disable.Whether to enable the Anti-island protection feature of this ESS or not.

Insulation_Enable:

Range: Enable/Disable.Whether to enable the Insulation Impedance monitoring function or not.

Island_R_ref:

0-250.The lower limit of impedance for referring to judge whether the insulation impedance of this ESS is normal or not.

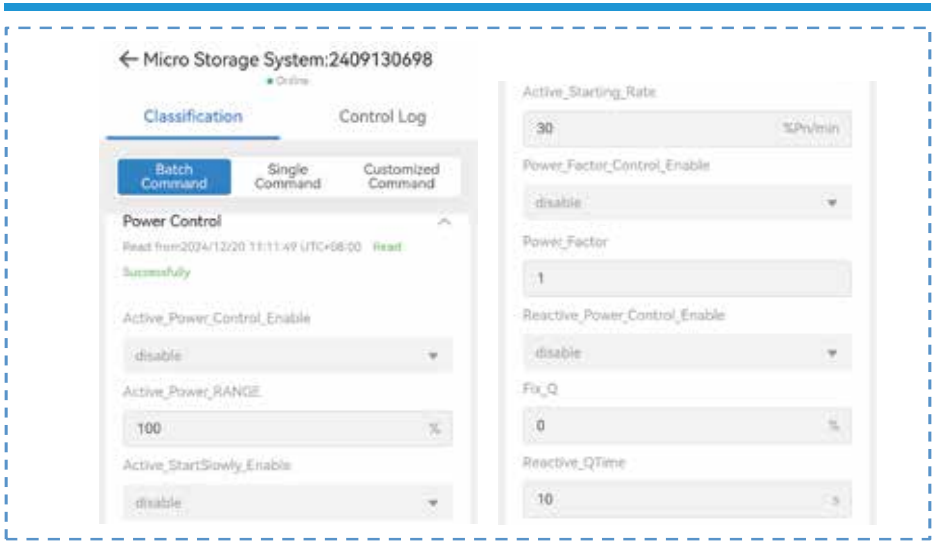

Power Control

Active_Power_Control_Enable:

Range: Enable/Disable. Whether to enable active power control function or not.

Active_Power_RANGE:

0-120. maximum output active power percentage compare to rated output power.

Active_StartSlowly_Enable:

Range: Enable/Disable. After starting, the output active power of this ESS will rise slowly in set rate.

Active_Starting_Rate:

0.00-100.00. After enabling Active Starting Rate, the output active power of this ESS will rise slowly in this set rate.

Power_Factor:

-1.000-1.000. To set the power factor of output power of this ESS.

Power_Factor_Control_Enable:

Range: Enable/Disable. Whether to enable reactive power control function or not.

Fix_Q:

-100.00~100.00. The set maximum percentage of reactive power output or absorption.

Reactive_QTime:

0-100. The time taken to reach the set Fix_Q.

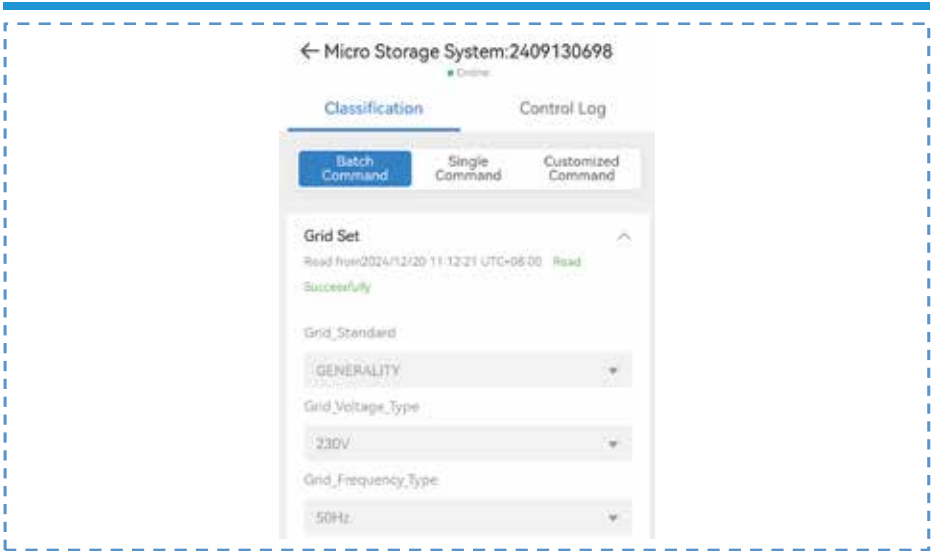

Grid Set

Grid_Standard:

Range: USER_DEFINED, GENERALITY, VDE_AR_N_4105, etc. To choose the desired grid code according to your local standard.

Grid_Voltage_Type:

Range: 208/220/230/240. In on-grid mode, set this value according to the AC voltage between the live line and neutral line of your grid. While in off-grid mode, set this value according to the rated voltage of your loads.

Grid_Frequency_Type:

Range: 50/60Hz. In on-grid mode, set this value according to the frequency of your grid. While in off-grid mode, set this value according to the rated frequency of your loads.

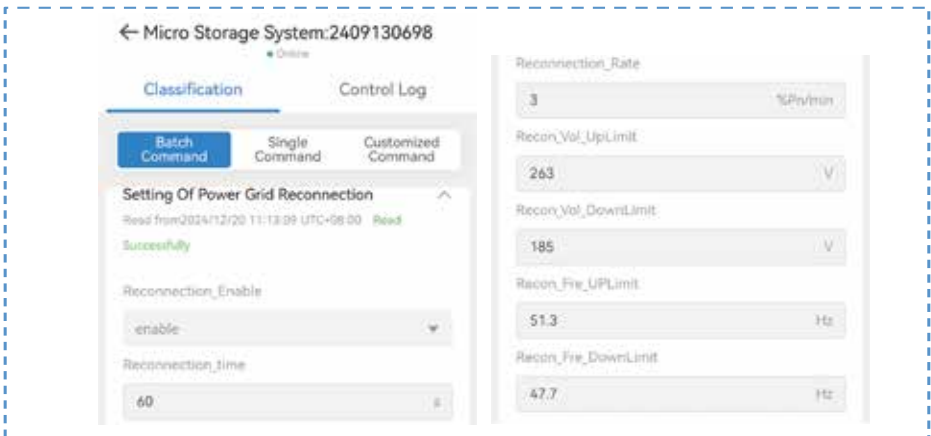

Setting Of Power Grid Reconnection

Reconnection_Enable:

Range: Enable/Disable. Whether to enable the power grid reconnection function or not.

Reconnection_time:

Range: 0~1000. Within the set time, the voltage and frequency of the power grid are maintained within the set range, then the main relays at the grid port of this ESS will be reconnected.

Reconnection_Rate:

Range: 0.00-100.00. Percentage increase in maximum output power of this ESS per minute after reconnection begins.

Recon_Vol_UpLimit:

50-300. The upper limit of the grid voltage for checking whether it is allowed to reconnect to the grid or not.

Recon_Vol_DownLimit:

50-300. The lower limit of the grid voltage for checking whether it is allowed to reconnect to the grid or not.

Recon_Fre_UpLimit:

45-65. The upper limit of the grid frequency for checking whether it is allowed to reconnect to the grid or not.

Recon_Fre_DownLimit:

45-65. The lower limit of the grid frequency for checking whether it is allowed to reconnect to the grid or not.

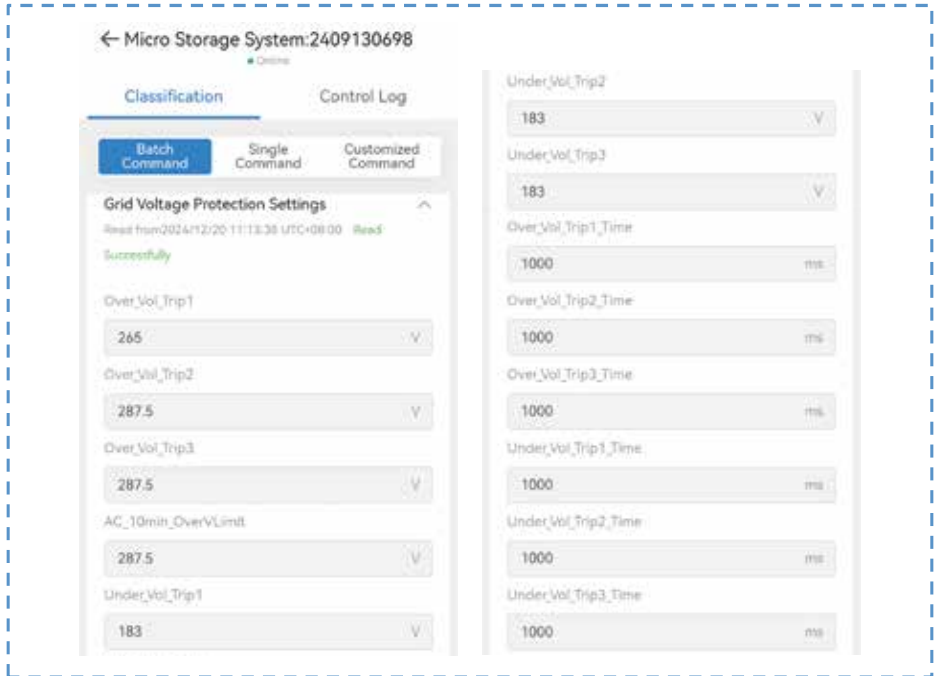

Grid Voltage Protection Settings

Over_Vol_Trip1:

Range: 10.0-300.0. Voltage threshold for level 1 overvoltage protection.

Over_Vol_Trip2:

Range: 10.0-300.0. Voltage threshold for level 2 overvoltage protection.

Over_Vol_Trip3:

Range: 10.0-300.0. Voltage threshold for level 3 overvoltage protection.

AC_10min_OverVLimit:

Range: 10.0-300.0. If the average value of the grid voltage within 10 minutes reaches this set value, overvoltage protection will take effect.

Under_Vol_Trip1:

Range:10.0-300.0.Voltage threshold for level 1 undervoltage protection.

Under_Vol_Trip2:

Range:10.0-300.0.Voltage threshold for level 2 undervoltage protection.

Under_Vol_Trip3:

Range:10.0-300.0.Voltage threshold for level 3 undervoltage protection.

Over_Vol_Trip1_Time:

Range:10-400000.The main relays of grid port will trip within this set time when the level 1 overvoltage protection takes effect.

Over_Vol_Trip2_Time:

Range:10-400000.The main relays of grid port will trip within this set time when the level 2 overvoltage protection takes effect.

Over_Vol_Trip3_Time:

Range:10-400000.The main relays of grid port will trip within this set time when the level 3 overvoltage protection takes effect.

Under_Vol_Trip1_Time:

Range:10-400000.The main relays of grid port will trip within this set time when the level 1 undervoltage protection takes effect.

Under_Vol_Trip2_Time:

Range:10-400000.The main relays of grid port will trip within this set time when the level 2 undervoltage protection takes effect.

Under_Vol_Trip3_Time:

Range:10-400000.The main relays of grid port will trip within this set time when the level 3 undervoltage protection takes effect.

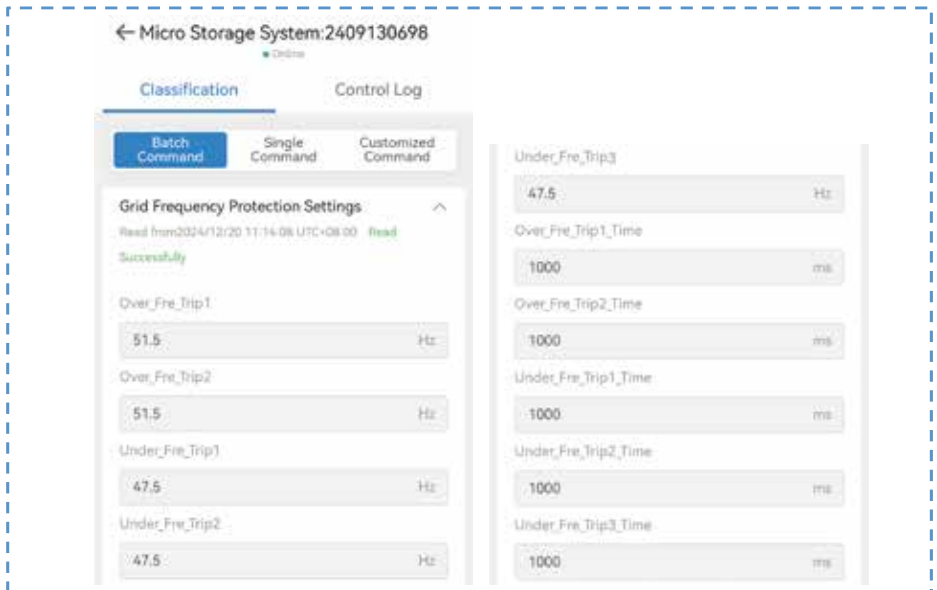

Grid Frequency Protection Settings

Over_Fre_Trip1:

45-65.Frequency threshold for level 1 overfrequency protection.

Over_Fre_Trip2:

45-65.Frequency threshold for level 2 overfrequency protection.

Under_Fre_Trip1:

45-65.Frequency threshold for level 1 underfrequency protection.

Under_Fre_Trip2:

45-65.Frequency threshold for level 2 underfrequency protection.

Under_Fre_Trip3:

45-65.Frequency threshold for level 3 underfrequency protection.

Over_Fre_Trip1_Time:

Range:10-400000.The main relays of grid port will trip within this set time when the level 1 overfrequency protection takes effect.

Over_Fre_Trip2_Time:

Range:10-400000.The main relays of grid port will trip within this set time when the level 2 overfrequency protection takes effect.

Under_Fre_Trip1_Time:

Range:10-400000.The main relays of grid port will trip within this set time when the level 1 underfrequency protection takes effect.

Under_Fre_Trip2_Time:

Range:10-400000.The main relays of grid port will trip within this set time when the level 2 underfrequency protection takes effect.

Under_Fre_Trip3_Time:

Range:10-400000.The main relays of grid port will trip within this set time when the level 3 underfrequency protection takes effect.

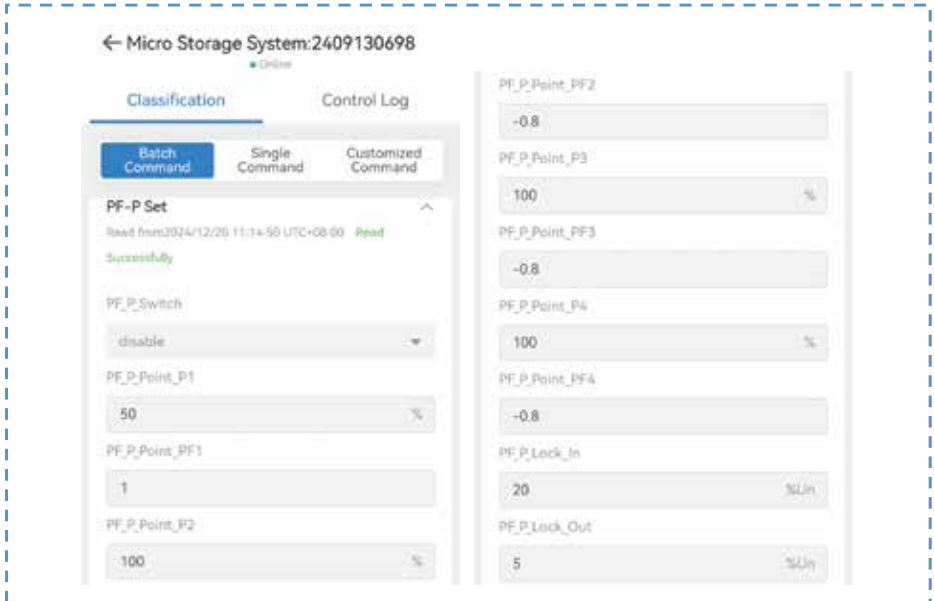

PF-P Set

PF_P_Switch:

Range: Enable/Disable.Whether to enable the PF_P function or not so that the ESS can adjust the power factor of its output power based on the output active power.

PF_P_Point_P1:

Range:0.00-100.00.Active power point 1 of PF_P function.

PF_P_Point_PF1:

Range:-1.000~-0.800,0.800~1.000.The set power factor of ESS at active power point 1.

PF_P_Point_P2:

Range:0.00-100.00.Active power point 2 of PF_P function.

PF_P_Point_PF2:

Range:-1.000~-0.800,0.800~1.000.The set power factor of ESS at active power point 2.

PF_P_Point_P3:

Range:0.00-100.00.Active power point 3 of PF_P function.

PF_P_Point_PF3:

Range:-1.000~-0.800,0.800~1.000.The set power factor of ESS at active power point 3.

PF_P_Point_P4:

Range:0.00-100.00.Active power point 4 of PF_P function.

PF_P_Point_PF4:

Range:-1.000~-0.800,0.800~1.000.The set power factor of ESS at active power point 4.

PF_P_Lock_In:

Range:0.00-120.00.When the PF-P function is not activated, if the percentage of active power output increases to this set value, the PF-P function will take effect.

PF_P_Lock_Out:

Range:0.00-120.00.When the PF-P function takes effect, if the percentage of active power output decreases to this set value, the PF-P function will not take effect any more.

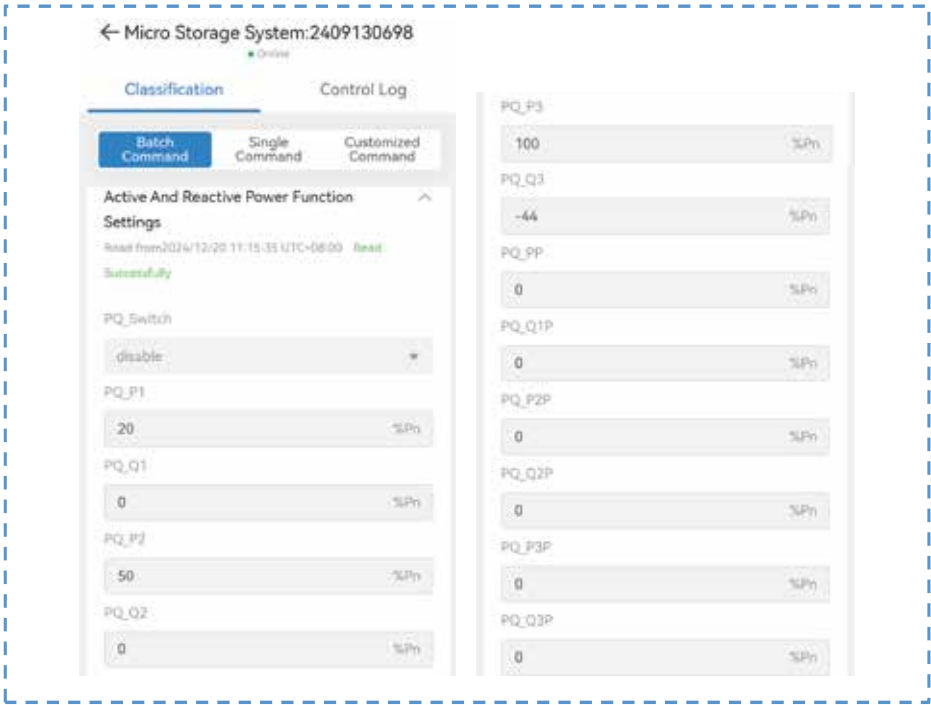

Active And Reactive power Function Settings

PQ_Switch:

Range: Enable/Disable.Whether to enable PQ function so that the ESS can adjust its output or input reactive power based on the output or input active power.

PQ_P1:

Range:0.00~110.00.Output active power point 1 of PQ function.

PQ_Q1:

-44.00-0.00.When the active power output by ESS reaches the value set by PQ_P1,the upper limit of the reactive power output by ESS can reach this set value.

PQ_P2:

Range:0.00~110.00.Output active power point 2 of PQ function.

PQ_Q2:

-44.00-0.00.When the active power output by ESS reaches the value set by PQ_P2,the upper limit of the reactive power output by ESS can reach this set value.

PQ_P3:

Range:0.00~110.00.Output active power point 3 of PQ function.

PQ_Q3:

-44.00-0.00.When the active power output by ESS reaches the value set by PQ_P3,the upper limit of the reactive power output by ESS can reach this set value.

PQ_P1P:

Range:-110.00~0.00.Input active power point 1 of PQ function.

PQ_Q1P:

0.00-44.00.When the active power input to ESS reaches the value set by PQ_P1P the upper limit of the reactive power input to ESS can reach this set value.

PQ_P2P:

Range:-110.00~0.00.Input active power point 2 of PQ function.

PQ_Q2P:

0.00-44.00.When the active power input to ESS reaches the value set by PQ_P2P the upper limit of the reactive power input to ESS can reach this set value.

PQ_P3P:

Range:-110.00~0.00.Input active power point 3 of PQ function.

PQ_Q3P:

0.00-44.00.When the active power input to ESS reaches the value set by PQ_P3P the upper limit of the reactive power input to ESS can reach this set value.

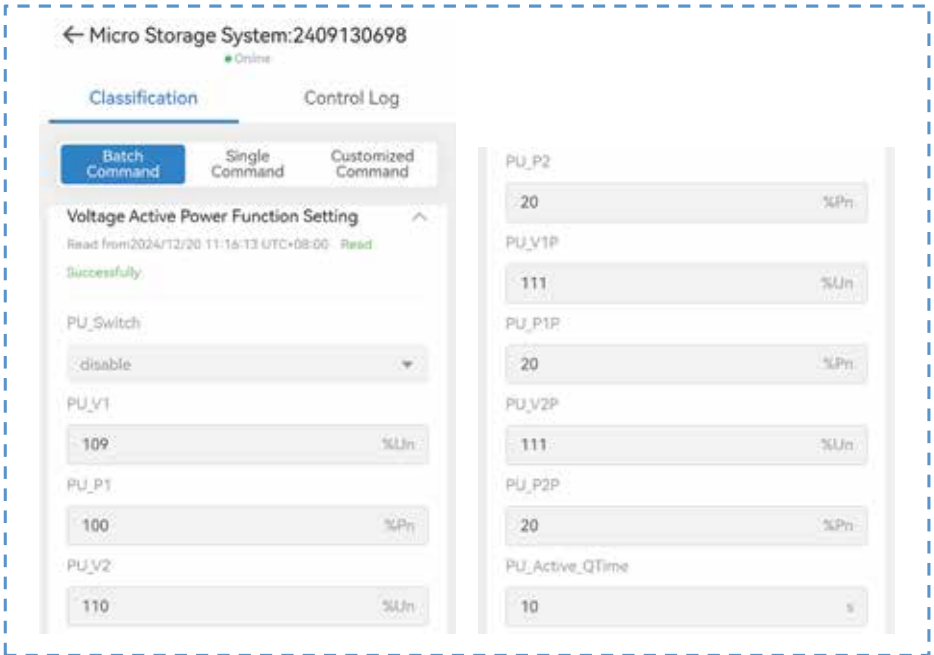

Voltage Active Power Function Setting

PU_Switch:

Range: Enable/Disable.Whether to enable PU function so that the ESS can adjust its output active power based on the grid voltage.

PU_V1:

Range:100.00~130.00.High point 1 of power grid voltage for PU function.

PU_P1:

Ranger:-100.00~100.00.When the grid voltage reaches the value set by PU_V1, the upper limit of the active power output by ESS will drop to this set value.

PU_V2:

Ranger:100.00~130.00.High point 2 of power grid voltage for PU function.

PU_P2:

Ranger:-100.00~100.00.When the grid voltage reaches the value set by PU_V2, the upper limit of the active power output by ESS will drop to this set value.

PU_V1P:

Ranger:100.00~130.00.Low point 1 of power grid voltage for PU function.

PU_P1P:

Ranger:-100.00~100.00.When the grid voltage drop to the value set by PU V1P, the upper limit of the active power output by ESS can reach this set value.

PU_V2P:

Ranger:100.00~130.00.Low point 2 of power grid voltage for PU function.

PU_P2P:

Ranger:-100.00~100.00.When the grid voltage drop to the value set by PU V2P, the upper limit of the active power output by ESS can reach this set value.

PU_Active_QTime:

Ranger:0.1~60.0.Response time for active power input or input upper limit adjustment.

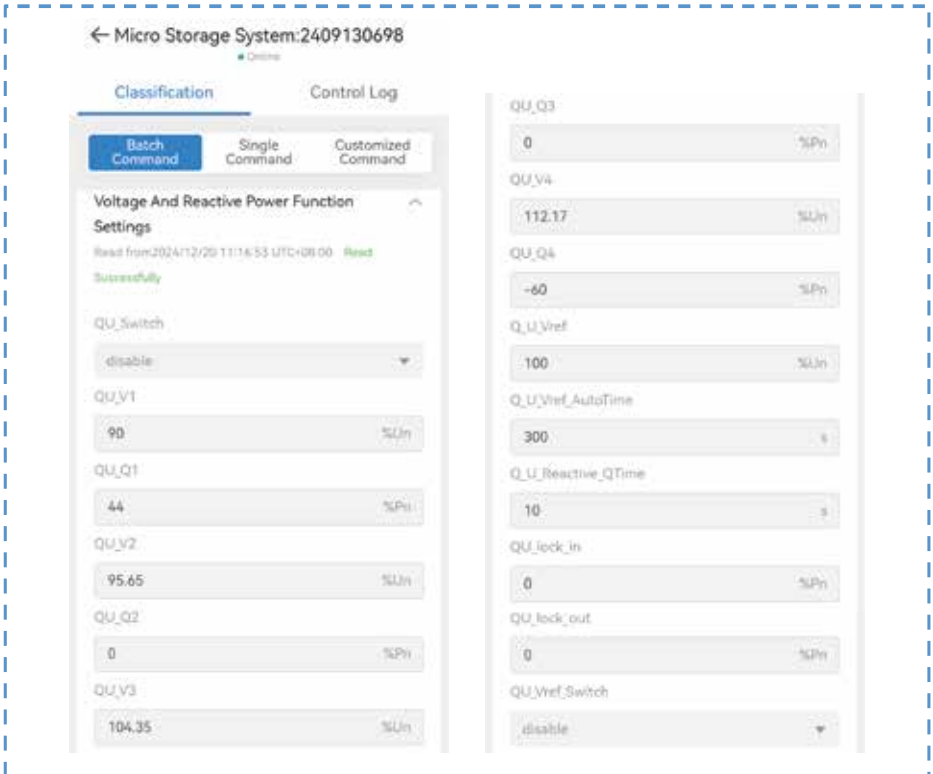

Voltage And Reactive power Function Settings

QU_Switch:

Range: Enable/Disable.Whether to enable QU function so that the ESS can adjust its output/input reactive power based on the grid voltage.

QU_V1:

Range:80.00~120.00.Grid voltage point 1 of QU function.

QU_Q1:

Range:-60.00~60.00.When the grid voltage reaches the value set by QU_V1, the upper limit of the reactive power output/input of ESS can reach this set value.

QU_V2:

Range:80.00~120.00.Grid voltage point 2 of QU function.

QU_Q2:

Range:-60.00~60.00.When the grid voltage reaches the value set by QU_V2, the upper limit of the reactive power output/input of ESS can reach this set value.

QU_V3:

Range:80.00~120.00.Grid voltage point 3 of QU function.

QU_Q3:

Range:-60.00~60.00.When the grid voltage reaches the value set by QU_V3, the upper limit of the reactive power output/input of ESS can reach this set value.

QU_V4:

Range:80.00~120.00.Grid voltage point 4 of QU function.

QU_Q4:

Range:-60.00~60.00.When the grid voltage reaches the value set by QU_V4, the upper limit of the reactive power output/input of ESS can reach this set value.

Q_U_Vref_Auto:

Range:90.00~110.00.Reference point for calculating the percentage of 1-4 grid voltage points.

Q_U_Vref_AutoTime:

300-5000.Response time for adjusting the voltage reference point from the previous value to the current voltage value.

Q_U_Reactive_QTime:

1~90.Response time for active power output or input upper limit adjustment.

QU_lock_in:

0.00~30.00% Pn.When the active power output of ESS rises to this set value, QU will transition from disable state to enable state automatically.

QU_lock_out:

0.00~30.00% Pn.When the active power output of ESS drops to this set value, QU will transition from enable state to disable state automatically.

QU_Vref_Switch:

Range: Enable/Disable.Whether to enable the Q_U_Vref_Auto function or not.

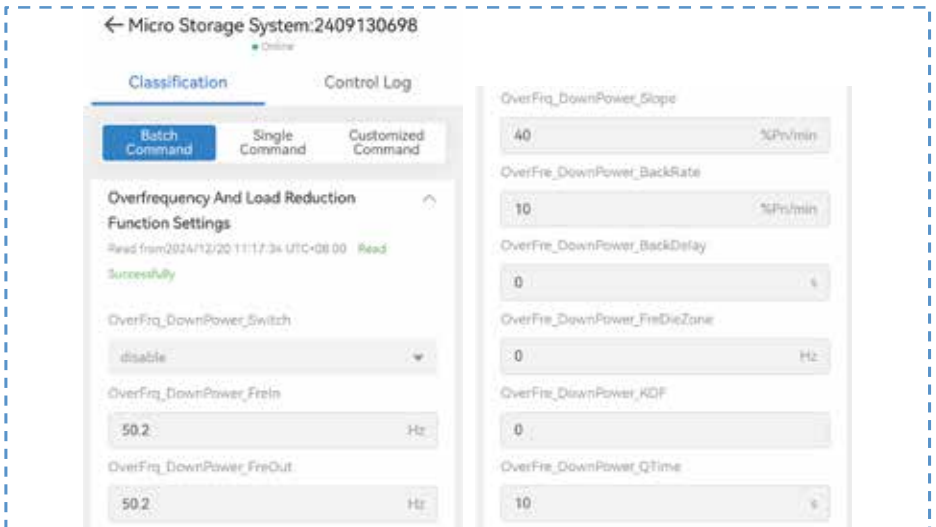

Overfrequency And Load Reduction Function Settings

OverFrq_DownPower_Switch:

Range: Enable/Disable. Whether to reduce the maximum output power when the grid frequency rises to the set values.

OverFrq_DownPower_FreIn:

Range: 45~65Hz. The starting frequency point for OverFrq_DownPower function.

OverFrq_DownPower_FreOut:

Range: 45~65Hz. The exiting frequency point for OverFrq_DownPower function.

OverFre_DownPower_Slope:

Range: 0.00~100.00. The slope of the decrease in output power after the grid frequency reaches the set value of OverFrq_DownPower_FreIn.

OverFre_DownPower_BackRate:

Range: 0.00~100.00. The slope of resuming its output power to the rated power after the grid frequency drops to the set value of OverFrq_DownPower_FreOut.

OverFre_DownPower_BackDelay:

Range: 0.1~60.0. The delay time before resuming the output power of ESS after the grid frequency drops to the set value of OverFrq_DownPower_FreOut.

OverFre_DownPower_FreDieZone:

Range: 0.017~1.000. The allowed offset of frequency starting point and exiting point, only used for US Grid standard.

OverFre_DownPower_KOF:

Range: 0.020~0.070. Calculation coefficients related to OverFre_DownPower_Slope and OverFre_DownPower_BackRate, only used for US Grid standard.

OverFrq_DownPower_QTime:

Range: 0.1~60.0. Response time for adjusting the upper limit of active power output to the limit value of OverFre_DownPower function.

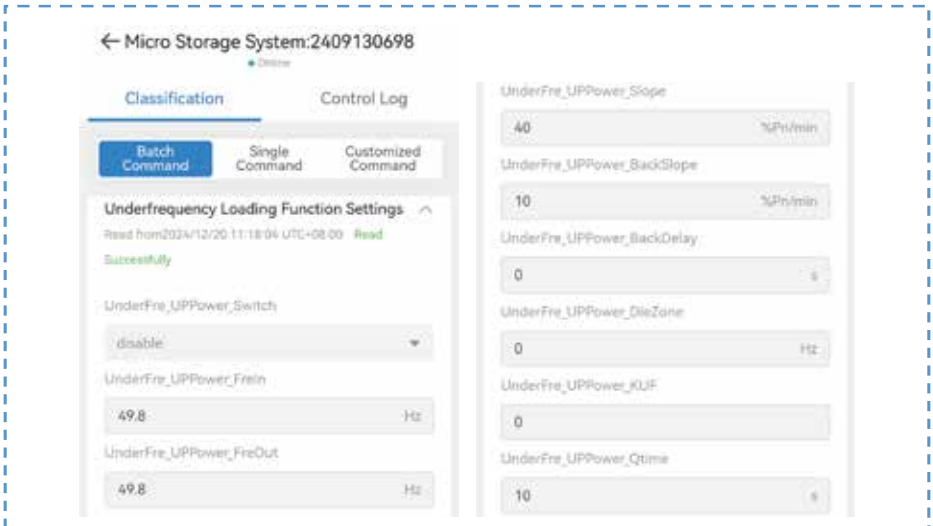

Underfrequency Loading Function Settings

UnderFrq_UPPower_Switch:

Range: Enable/Disable. Whether to increase the maximum output power when the grid frequency drops to the set values.

UnderFrq_UPPower_FreIn:

Range: 45~65Hz. The starting frequency point for UnderFre_UPPower function.

UnderFre_UPPower_FreOut:

Range: 45~65Hz. The exiting frequency point for OverFrq_DownPower function.

UnderFre_UPPower_Slope:

Range:0.00-100.00.The slope of the increase in output power after the grid frequency drops to the set value of UnderFre_UPPower_FreIn.

UnderFre_UPPower_BackSlope:

Range:0.00-100.00.The slope of resuming ESS output power to the rated power after the grid frequency returns to the set value of UnderFre_UPPower_FreOut.

UnderFre_UPPower_BackDelay:

Range: 0.1~60.0.The delay time before resuming the output power of ESS after the grid frequency returns to the set value of UnderFre_UPPower_FreOut.

UnderFre_UPPower_DieZone:

Range: 0.017~1.000.The allowed offset of frequency starting point and exit point,only used for US Grid standard.

UnderFre_UPPower_KUF:

Range: 0.020~0.070.Calculation coefficients related to OverFre_DownPower_Slope and OverFre_DownPower_BackRate,only used for US Grid standard.

UnderFre_UPPower_QTime:

Range: 0.1~60.0.Response time for adjusting the upper limit of active power output to the limit value of UnderFre_UPPower function.

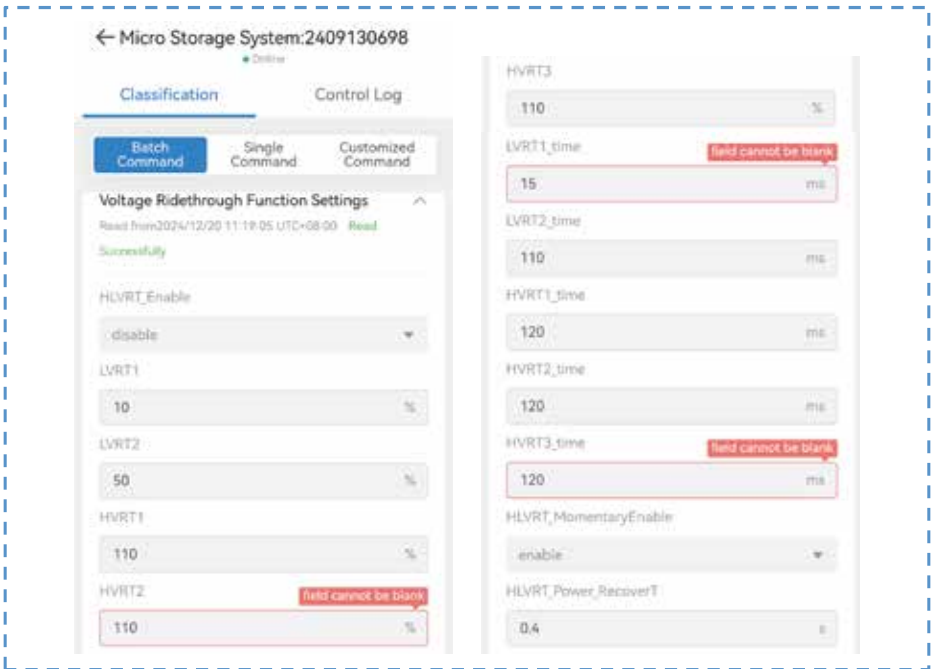

Voltage Ridethrough Function Settings

HLVRT_Enable:

Range: Enable/DisableAfter enabling this function,even if the voltage of the power grid temporarily drops below a certain percentage of the rated voltage or rises above a certain percentage of the rated voltage due to faults or fluctuations, ESS can continue to maintain grid connected operation for a certain period of time.

LVRT1:

Range:0.00-100.00.At which percentage of rated voltage the grid voltage drops below.

LVRT2:

Range:0.00-100.00.At which percentage of rated voltage the grid voltage drops below.

HVRT1:

Range:0.00-150.00.At which percentage of rated voltage the grid voltage rises above.

HVRT2:

Range:0.00-150.00.At which percentage of rated voltage the grid voltage rises above.

HVRT3:

Range:0.00-150.00.At which percentage of rated voltage the grid voltage rises above.

LVRT1_time:

Range:0.1~6553.5.When the grid voltage drops below LVRT1, ESS can continue to maintain grid connected operation for this set time, waiting for the grid voltage to return to the normal range.

LVRT2_time:

Range:0.1~6553.5.When the grid voltage drops below LVRT2, ESS can continue to maintain grid connected operation for this set time, waiting for the grid voltage to return to the normal range.

HVRT1_time:

Range:0.1~6553.5.When the grid voltage rises above HVRT1, ESS can continue to maintain grid connected operation for this set time, waiting for the grid voltage to return to the normal range.

HVRT2_time:

Range:0.1~6553.5.When the grid voltage rises above HVRT1, ESS can continue to maintain grid connected operation for this set time, waiting for the grid voltage to return to the normal range.

HVRT3_time:

Range:0.1~6553.5.When the grid voltage rises above HVRT1, ESS can continue to maintain grid connected operation for this set time, waiting for the grid voltage to return to the normal range.

HLVRT_MomentaryEnable:

Range: Enable/Disable.Whether or not to enable the function of the inverter to maintain grid connected operation without disconnecting from the grid when the current drops to zero due to a fault in the power grid.

HLVRT_Power_RecoverT:

Range:0.00-10.00.After maintaining zero current passthrough until the power grid returns to normal, the response time for ESS to restore normal output power.

7. Application modes

ESS can be used as a household energy storage system and a portable outdoor power source. Based on whether ESS is connected to photovoltaics, connected or disconnected from the grid, with or without CT/meter, and the differences in working mode settings, ESS can be used in various application scenarios and can be flexibly converted.

Mode	Time of use	Batt(Target SOC) of Each time period	Grid_charging_Enable under "Storage Inverter Work mode-1"	Grid Charge under "Storage Inverter Work mode-2"
Green Power Mode (Default)	Enable	Follow the set value of "Battery_LowBattSOC" under Battery Settings	Enable	Disable
Full Charge Mode	Disable	Disable	Enable	Disable
Customized Mode	Customized	Customized	Customized	Customized

Green Power Mode with CT

Scenario 1: During the day time, Solar power < Load power and Battery SOC is lower than Battery_LowBattSOC, Load will be supplied by solar power and grid power together.

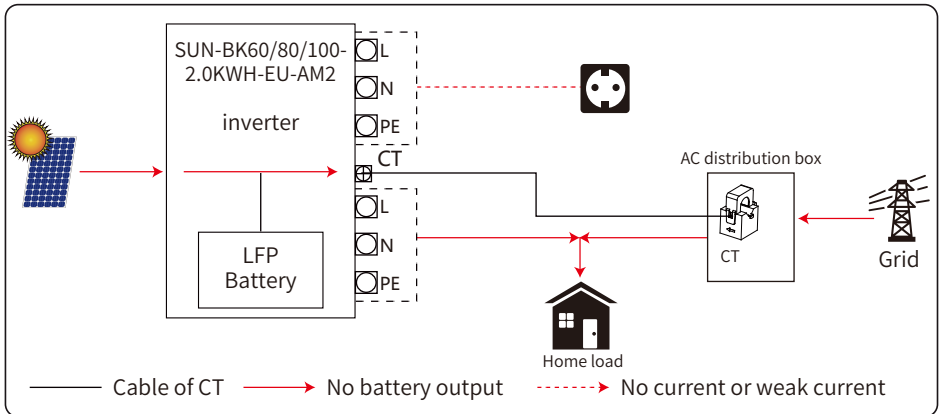

Scenario 2: During the day time, Solar power < Load power and Battery is able to discharge, battery will discharge to supply the loads with solar power together, if the load power demand cannot be met, power will still be taken from the grid.

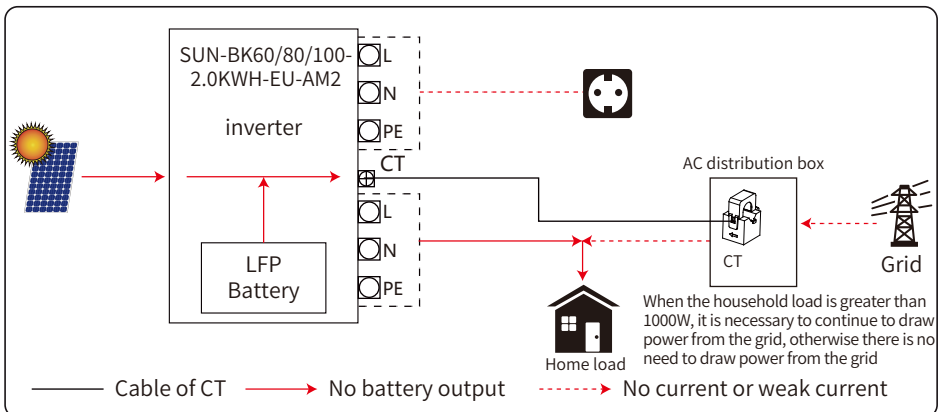

Scenario 3: During the day time, Solar power > Load power, the excess power will firstly be charged into the battery, if there is still excess power, you can choose whether to sell it to the grid.

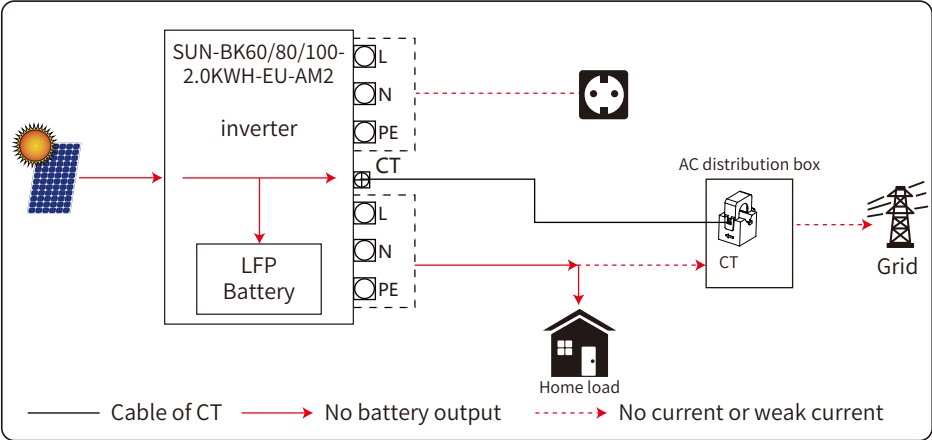

Scenario 4: During the day time, Solar power < charging power, and there is another PV system with sufficient power generation selling power to the grid, this ESS will turn to charging mode automatically.

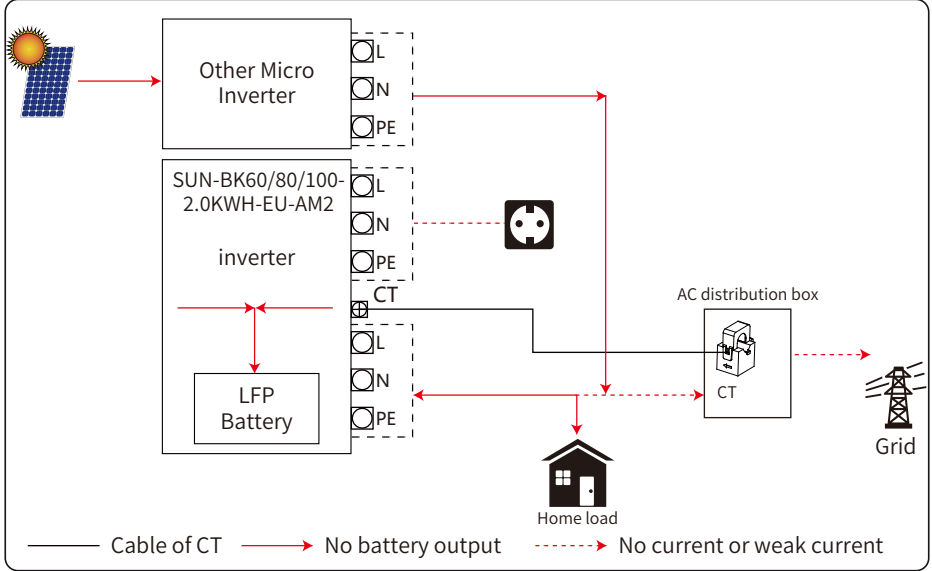

Scenario 5: During the night time, the battery SOC is higher enough to be able to discharge. If the discharging power of battery is insufficient, the power grid will supplement it.

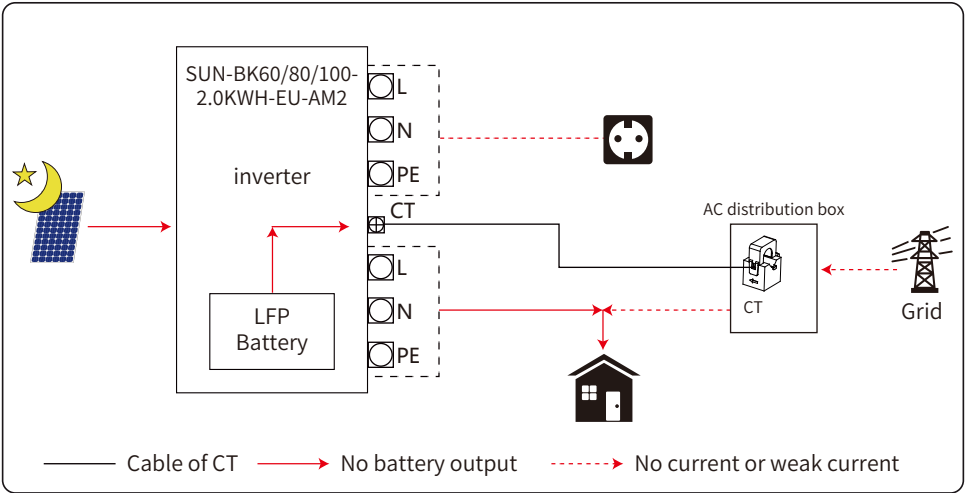

Scenario 6: During the night time, the battery SOC is too low to discharge, so the loads will totally be supplied by grid.

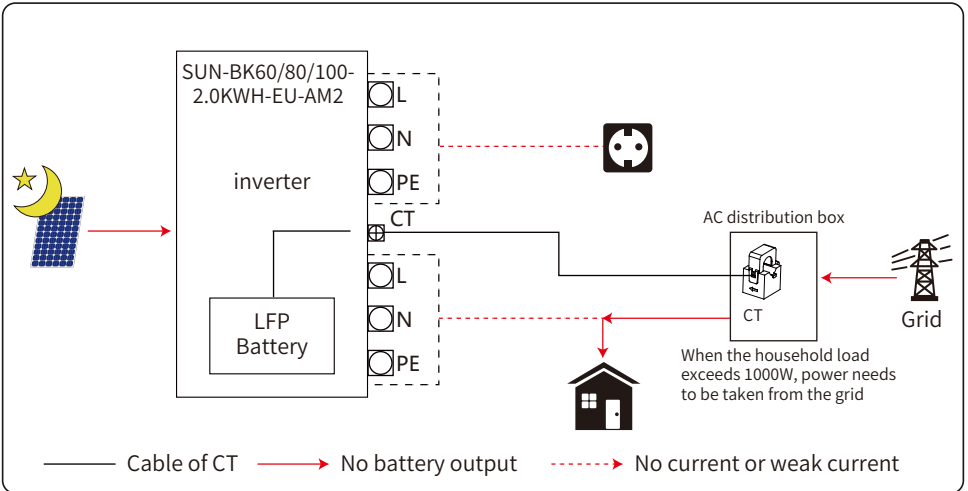

Green Power Mode without CT(Zero Export to UPS load)

Scenario 7: During the day time, the PV power will firstly used to supply the backup load, the excess power will be used to charge the battery, if it still has excess power, you can choose to sell it to grid or not.

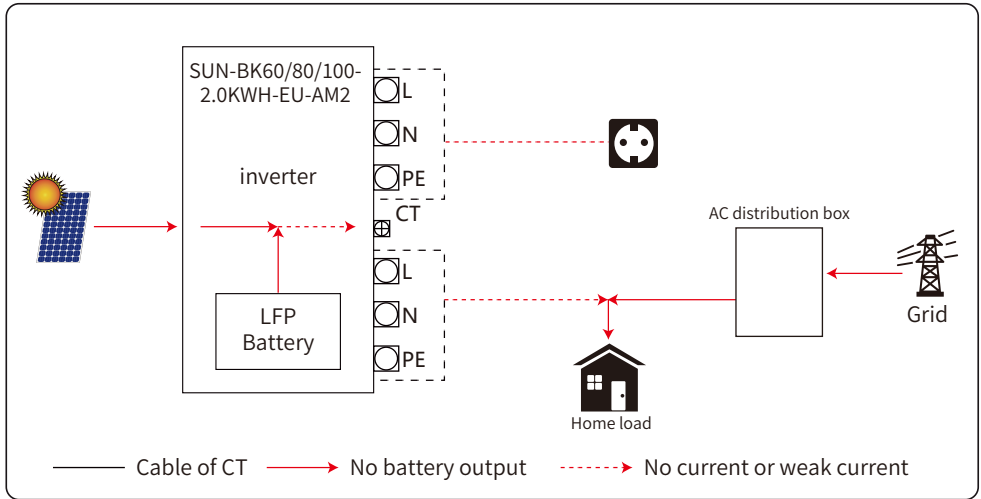

Scenario 8: During the night time, the battery SOC is higher enough to discharge. The discharging power will firstly be used to supply loads on load port, and whether to export power to grid port will depends on the setting of Limit_control_function.

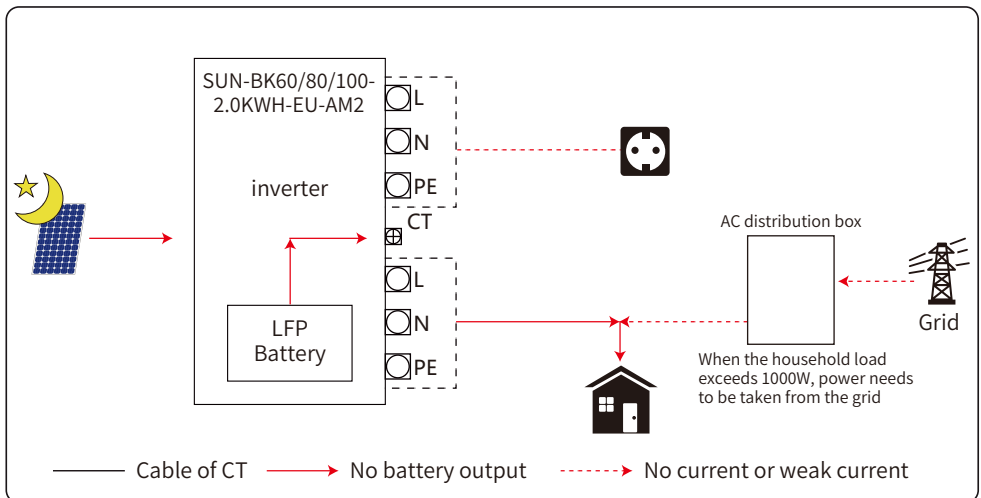

Full Charge Mode (On-grid)

Charge the battery in max_charge_current with solar and grid power.

PV power is sufficient: PV power will firstly charge the battery, the excess power can be used to supply the loads or even sell to grid as desired

PV power is insufficient: PV power will be used to charge the battery, the insufficient part will be supplied by the power grid, and the power needed by the load is also provided by the power grid.

After the battery is fully charged, it will automatically stop charging. During day time, the excess PV power will be used to supply loads or sell to grid as desired.

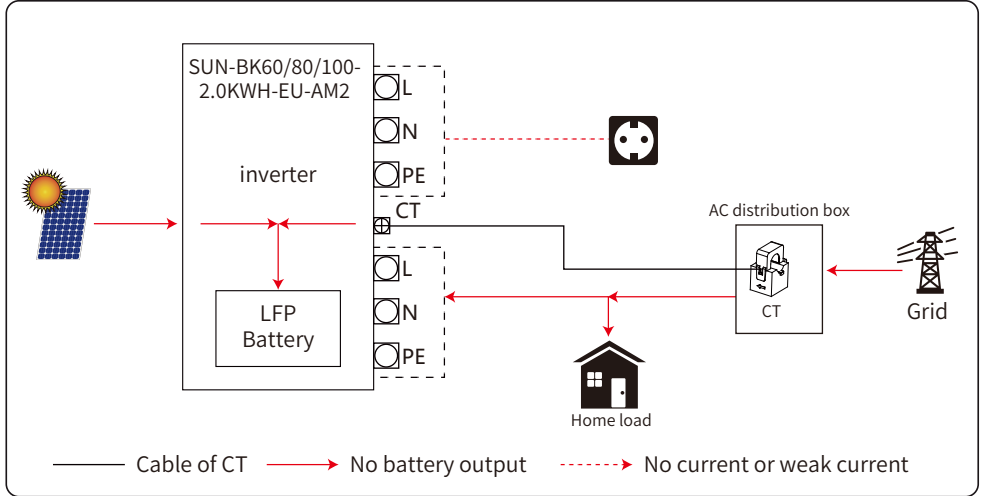

Purpose of this Mode:

(1) To prepare for portable applications or planned power outages, fully charge the battery in advance.

(2) Forcefully recharge and calibrate SOC when the battery has not been fully charged for a long time or SOC is too lower due to has not been charged for a long time.

Off-Grid Application scenrio: Portable/UPS power source

Insert the plug of power strip into the Schuko socket on load port of ESS to expand the numbers of usable sockets.

During day time, PV power will firstly be used to supply the load, and excess power can be used to charge the battery. Else If PV power is insufficient, battery will discharge to supply loads together with PV power (until reaching Low Batt)

During the night time, the battery will discharge to supply power to load until reaching Low Batt.

During outage, this ESS can be used as a little-scale UPS power source, maximum output power is only 1000W, and the backup hours depends on the UPS load power and the remaining SOC of battery.

For example: Laptop 60W, SOC 100% can supply power to it for nearly 30 hours.

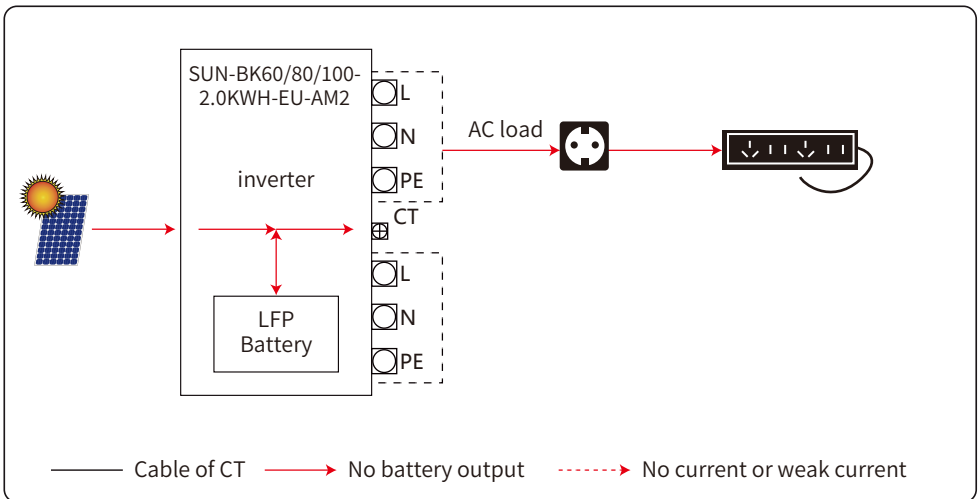

8. Use of the Extender Battery Module

The extender battery module is used in conjunction with the SUN-BK60/80/100-2.0KWH-EU-AM2 Balcony Energy Storage System. Up to four extender battery modules can be connected to the system, enabling a capacity expansion by up to 10kWh to meet the user's demand for a larger battery capacity.

8.1 Parameters and Specifications of the Extender Battery module

Model	AE-F2.0
Battery Technical Specification	
Battery Chemistry	LiFePO ₄
Battery Nominal Voltage	51.2V
Battery Nominal Energy	2kWh
Max.Charging/Discharging Current	25A
Battery Operating Voltage	44.8V-57.6V
Battery Cycle Life	≥6000(@25°C±2°C,0.5C/0.5C,70%EOL)
Parallel Capability	4pcs
Other Technical Specification	
Display	LCD(SOC,ALARM)
Communication interfaces	CAN2.0,LoRa
Dimension(WxDxH)	450x210x244mm
Weight Appr.	20kg
Operating Temperature Range	-10°C~50°C
Max.operating altitude	3000m
Relative Humidity	15%~85%(No Condensing)
Battery Certification	UN38.3,IEC62619,CE
Installation Style	Floor-Mounted

8.2 Connection Method for AE-F2.0

1. First, make sure that AE-F2.0 extender battery module and SUN-BK60/80/100-2.0KWH-EU-AM2 are turned off, and open the dust covers on the connection ports.
2. Connect the AE-F2.0 extender module to the SUN-BK60/80/100-2.0KWH-EU-AM2 battery system using the connecting cable. (Note: The two connection ports on SUN-BK60/80/100-2.0KWH-EU-AM2 are designated for input and output, respectively. Connect the BAT-IN port of the AE-F2.0 extender module to the BAT-OUT port of the SUN-BK60/80/100-2.0KWH-EU-AM2 battery system.)
3. Check if the connecting cables between the AE-F2.0 extender module and the SUN-BK60/80/100-2.0KWH-EU-AM2 battery system are securely plugged in.
4. Turn on the power switch of the AE-F2.0 extender module first and check that the LED indicator lights up, then turn on the power switch of the SUN-BK60/80/100-2.0KWH-EU-AM2 battery system and check that the display screen lights up. If there is no faults or alarm, the connection is successful.

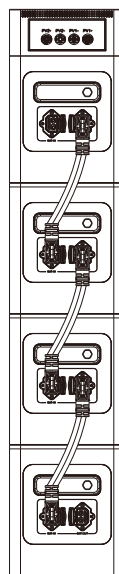

8.3 Precautions during Use

1. Before connecting the battery system with the extender modules, please make sure that they are all turned off.
2. Do not connect or disconnect the extender modules during active charging or discharging . To disconnect or remove the extender modules, please first turn off the battery system and the extender modules.
3. Please do not make physical contact with the connection joints of the extender modules with hands or any other objects. If foreign particles are found on the connection joints, gently wipe them off with a dry cloth.
4. When connecting the extender modules, ensure that the connecting cables between the extender modules and the SUN-BK60/80/100-2.0KWH-EU-AM2 battery system is inserted tightly. Failure to secure the connecting cables may result in overheating of the connection joints, affecting the system's performance. In severe cases, it could lead to a fire.

9. FAQ

Q1: What type of battery is used for the product? Is the battery safe?

The high-quality lithium iron phosphate battery is used for the product. The battery can operate safely and normally as the system is developed with multiple protection strategies which protect against scenarios of undervoltage, overvoltage, overcurrent, low temperature, and high temperature.

Q2: How to determine if the system is charging or discharging?

During charging or discharging, the LCD screen will display the remaining time while the power indication icon next to the battery percentage one starts to rotate circularly and displays the input/output power. The LED light will flash during charging and discharging.

Q3: Can the system charge and discharge at the same time?

Yes, but prolonged use in this manner may cause damage.

Q4: How to clean the product?

Please use a dry, soft, clean cloth or tissue to wipe it clean.

Q5: How to store the product?

Please cut off the power supply first, then store it in a dry, ventilated environment at a suitable temperature. Do not store the product in a damp, dusty environment at a high temperature or with high salinity, as these conditions are not conducive to the storage of the product and may cause damage to it. For long-term storage, it is recommended to discharge the battery to around 50% SOC every month, then recharge it to 100% SOC in order to extend the product's lifespan.

9. Common Faults and Troubleshooting Methods

Definitions and solutions of faults of the inverter module		
Fault Code	Definitions	Solutions
F01	DC_Inversed_Failure	Reserved.
F02	DC_Insulation_Failure	Reserved.
F03	GFDI_Failure	Reserved.
F04	GFDI_Ground_Failure	Reserved.
F05	EEPROM_Read_Failure	Reserved.
F06	EEPROM_Write_Failure	Reserved.
F07	DC/DC_Softstart_Fault	Reserved.
F08	GFDI_Relay_Failure	Reserved.
F09	IGBT_Failure	Reserved.
F10	AuxPowerBoard_Failure	Reserved.
F11	AC_MainContactor_Failure	Reserved.
F12	AC_SlaveContactor_Failure	Reserved.
F13	Grid_Mode_changed	Grid Mode changed When setting the inverter in grid mode, parallel mode, battery mode, and other related settings, this fault will be triggered. If settings no problem inverter can back to work mode.
F14	DC_OverCurr_Fault	DC over current fault Battery current exceeds the allowable value. If it occurs multiple times or cannot be restored after restarting, there may be the following reasons: Check the maximum discharge current setting;When in lithium battery mode, the maximum discharge current value of the lithium battery should be checked;Check the battery current sensor or circuits related to the sensor.
F15	SW_AC_OverCurr_Fault	AC over current Software Protection: When the inverter is running, if there is overload or severe grid distortion, it may cause the fault. If it cannot be restarted, there may be the following reasons: 1. IGBT or driver damage on the inverter side; 2.Current sensor or related circuit malfunction;
F16	GFCI_Failure	Reserved.
F17	Active_Battery_Hold	Reserved.

Fault Code	Definitions	Solutions
F18	Tz_Ac_OverCurr_Fault	AC over current Hardware protection: When the inverter is running, if there is overload or severe grid distortion, it may cause the fault. If it cannot be restarted, there may be the following reasons: 1. IGBT or driver damage on the inverter side; 2. Current sensor or related circuit malfunction;
F19	Tz_Integ_Fault	Reserved.
F20	Tz_Dc_OverCurr_Fault	DC hardware over current fault: The input hardware over current fault of the PV panel may be caused by the following reasons if it cannot be restored: 1. PV current sensor failure, or hardware over current protection detection circuit failure; 2. BOOST inductor damage;
F21	Tz_GFDI_OC_Fault	Reserved.
F22	Tz_EmergStop_Fault	Emergency stop fault: The inverter remains stopped. Contact the distributor
F23	Tz_GFCI_OC_Fault	Reserved.
F24	DC_Insulation_Fault	DC Insulation Fault 1. Check if the PV cable on site is break; 2. Check if the inverter assembled properly.
F25	Rreserved	Reserved.
F26	BusUnbalance_Fault	Reserved.
F27	PV_or_Grid_WAKE_UP_Failed	Battery wake up failure: The possible reasons for battery wake-up failure are: 1. boost failure during PV wake up. 2. The MOS or their drivers on both sides of the transformer are damaged.
F28	DCIOver_M1_Fault	Reserved.
F29	Parallel_Comm_Fault	Parallel communication error: 1. Setting error, set the desired function according to the corresponding instructions, determine the master/slave and its address and other Settings; 2. The communication line is not connected properly; The communication module is faulty. Check the devices related to the parallel port.
F30	AC_MainContactor_Fault	AC main contactor fault: Please check the Relays and their drivers.

Fault Code	Definitions	Solutions
F31	Soft_Start_Failed	Reserved.
F32	DCIOver_M2_Fault	Over charging current fault: This is a software protection to prevent excessive charging current from affecting the battery, which rarely occurs for the following reasons: 1. Full power charging, PV and grid fluctuation; 2. The battery current sensor is faulty.
F33	AC_OverCurr_Fault	AC Over Current Fault 1. The bypass load is heavy. Bypass CT (built-in Limiter sensor) or its detection of circuit faults.
F34	AC_Overload_Fault	AC Overload Fault 1. The AC load is too heavy 2. The power grid mode is selected incorrectly, for example, the European model is selected as a split phase 120V output 3. Not all IGBTs in AC inverter bridge working well.
F35	AC_NoUtility_Fault	AC No Utility Fault When there is no battery mode or a battery has problem, this fault is reported during the Grid-connected mode.
F36	AC_GridPhaseSeque_Fault	Reserved.
F37	Wake_up_Over_Current	Overcurrent fault during activating battery: Check the connection of power cable of battery terminals; Some of MOSFET components are broken.
F38	Parallel_system_Stop	Reserved.
F39	Tz_Resonance_OverCurr_Fault	DC LLC Over Current: 1. The heavy load suddenly accesses 2. Mosfet damaged 3. Resonant capacitor or transformer damage (uncommon) 4. Resonant current detection circuit fault (uncommon)
F40	Gen_OverCurr_Fault	Reserved.
F41	AC_WU_OverVolt_Fault	Grid over voltage fault This error will be reported only when the inverter work in no battery mode and works in grid-connected mode. 1. Check the Grid voltage 2. Check the internal voltage sampling.

Fault Code	Definitions	Solutions
F42	AC_WU_UnderVolt_Fault	Grid Under voltage fault This error will be reported only when the inverter work in no battery mode and works in grid-connected mode. 1. Check the Grid voltage 2. Check the internal voltage sampling.
F43	AC_VW_OverVolt_Fault	Reserved.
F44	AC_VW_UnderVolt_Fault	Reserved.
F45	AC_UV_OverVolt_Fault	Reserved.
F46	AC_UV_UnderVolt_Fault	Reserved.
F47	AC_OverFreq_Fault	Grid Over Frequency fault This error will be reported only when the inverter work in no battery mode and works in grid-connected mode. 1. Check the Grid voltage 2. Check the internal voltage sampling.
F48	AC_UnderFreq_Fault	Grid Under Frequency fault This error will be reported only when the inverter work in no battery mode and works in grid-connected mode. 1. Check the Grid voltage 2. Check the internal voltage sampling.
F49	Backup_Battery_Fault	Reserved.
F50	AC_softstart_Fault	Wait for the machine to attempt a restart, or press the inverter switch to restart the inverter. If it cannot be restored, contact the distributor
F51	Battery_TempHigh	Battery Temperature High fault When this fault occurs, power off the battery immediately to check the battery temperature.
F52	AC_A_InductCurr_DcHigh_Fault	Reserved.
F53	AC_B_InductCurr_DcHigh_Fault	Reserved.
F54	AC_C_InductCurr_DcHigh_Fault	Reserved.
F55	DC_VoltHigh_Fault	DC Voltage High Fault 1. Check the battery voltage 2. Check the input voltage of the PV 3. Check whether the capacitor is abnormally damaged;
F56	DC_VoltLow_Fault	DC Voltage Low Fault 1. Check the battery voltage 2. Check whether the bus capacitor is abnormally damaged;
F57	AC_BackFeed_Fault	Reserved.

Fault Code	Definitions	Solutions
F58	BMS_Communication_Fault	BMS Communication Fault 1. Check the connection between the battery BMS cable and the inverter 2. Check the lithium battery Settings and inverter Settings 3. If change a battery still not working, check the BMS communication circuit of the inverter.
F59	AC_V_GridCurr_High_Fault	The AC voltage and current are too high The fault occurs only when inverter work in no battery mode, and almost all of this situation work can be restored. If the inverter reports this failure very frequently may have the following reasons: 1. Weak power grid with serious distortion 2. Voltage detection failure.
F60	Gen_Volt_or_Fre_Fault	Reserved.
F61	Button_Manual_OFF	Reserved.
F62	DRMs_Stop	Reserved.
F63	Arc_Fault	Reserved.
F64	AC_V_GridCurr_High_Fault	Heat-sink High Temperature Fault 1. The ambient temperature is too high or the surrounding ventilation is bad; 2. The temperature sensor is faulty.

Definitions and solutions of faults of the battery module

Problem Description	Analysis Method	Measures
<p>If the on-site low-voltage battery can not obtain fault information from the SOC indicator lights, prioritize upgrading to the latest version of the battery firmware to retrieve fault information for further analysis.</p>		
<p>SOC fluctuations in a single battery pack system</p> <p>The SOC records on the cloud platform frequently exhibit fluctuations from SOC values above 10% to 0% or from below 90% to 100%.</p>	<ol style="list-style-type: none"> 1. Check the SOC logs to determine whether SOC fluctuations occur after reaching 0% or 100% SOC as starting points, while the current is sustained. Verify if SOC fluctuations happen during both charging to 100% and discharging to 0%, or if they only occur during charging/discharging processes. 2. If there are no fluctuations from 100% to 0% or from 0% to 100%, and if fluctuations occur only after more than 2 days without reaching full charge or full discharge; 	<ol style="list-style-type: none"> 1. If SOC fluctuations occur during both charging and discharging processes, it may indicate insufficient battery capacity. Determine if it is normal capacity degradation or abnormal capacity degradation based on the battery's usage duration. If abnormal degradation is identified, the customer should replace the battery. 2. If the fluctuations occur only during discharging and primarily happen after the battery has been idle for an extended period, it indicates that the zero drift of the battery current sampling is too significant. Customers should upgrade to a battery firmware with reduced zero drift for sampling.
<p>Mos sticking fault</p> <p>The battery displays a sticking indicator light.</p>	<ol style="list-style-type: none"> 1. Use a voltmeter to measure the voltage between P+ and P- to confirm if the voltage is around 51V, which is the battery voltage; 	<ol style="list-style-type: none"> 1. Upgrade to the latest battery firmware to clear the Mos sticking fault. <p>If there is a 51V voltage present at the P+ and P- terminals, it is necessary to replace the BMS board.</p>
<p>SOC fluctuations in multi-battery pack systems</p> <p>SOC records on the cloud platform often fluctuate from one SOC value to another, and after a certain period of time, they will return to the original value</p>	<ol style="list-style-type: none"> 1. Verify on-site whether individual batteries frequently display a red fault indicator light; 2. Retrieve battery historical events or fault codes for further analysis; 	<ol style="list-style-type: none"> 1. Replace the problematic battery pack or handle the specific issue according to the specific fault.
<p>No communication between the battery and the inverter</p>	<ol style="list-style-type: none"> 1. Check if the Deye inverter operating mode is set to lithium battery mode. 2. Check if the communication protocol setting for the Deye inverter is 00 (CAN communication mode). 3. Verify if there are normal messages on the battery pack communication port (PCS CAN), such as 0x350, 0x351, at a baud rate of 500k. 4. Check if the inverter communication port (CAN) is properly connected to the battery pack communication port (PCS CAN) using the correct connecting wire. 5. Review the test records to see if there are any PASS records for the PCS CAN communication test. 	<ol style="list-style-type: none"> 1. Once the issue is identified as per the analysis method, proceed with the corresponding solution.
<p>The battery SOC always stops at 99% and cannot reach 100%.</p>	<ol style="list-style-type: none"> 1. Check the power distribution of the inverter and verify if the charging current is allocated at the charging end according to the charging limit current reported by the battery 	<ol style="list-style-type: none"> 1. Modify the inverter settings;
<p>Voltage/Temperature disconnection fault reported</p> <p>The battery goes into abnormal sleep mode after the red light comes on</p>	<ol style="list-style-type: none"> 1. Check if there are any loose pins in the data acquisition line connector. 2. Verify if the data acquisition wiring harness is broken. 3. Inspect the BMS board for any burnt circuit in the data acquisition circuits. 	<ol style="list-style-type: none"> 1. Replace the data acquisition line; 2. Replace BMS;

Problem Description	Analysis Method	Measures
MOS over-temperature fault reported	<ol style="list-style-type: none"> 1. Check whether the screws of B- and P- power connectors are tightened and inspect for any loose soldering joints or disconnected pins on the terminal; 2. Inspect for any loose soldering joints or disconnected pins on the Mos. 	<ol style="list-style-type: none"> 1. Tighten the screws; 2. Replace BMS;
Cell high voltage protection	<ol style="list-style-type: none"> 1. Check if there are any abnormalities in the data acquisition wiring harness. 2. Measure cell voltages using a multi-meter. 3. Check the SOH of the battery pack 4. Check the historical records for instances of repeated charging with low current. 	<ol style="list-style-type: none"> 1. Replace the data acquisition line; 2. Replace BMS;
Cell low voltage protection	<ol style="list-style-type: none"> 1. Check if there are any abnormalities in the data acquisition wiring harness. 2. Measure cell voltages using a multi-meter. 3. Check the SOH of the battery pack 4. Check the historical records for instances of forced relay opening (cutting power) by the PCS. 	<ol style="list-style-type: none"> 1. Replace the data acquisition line; 2. Replace BMS; 3. Replace the battery pack.
Battery pack Overvoltage protection	<ol style="list-style-type: none"> 1. Check whether the charging and discharging MOS is functioning properly 2. Check the ambient temperature of the battery pack. 3. Check if the battery pack is too old or damaged. 	<ol style="list-style-type: none"> 1. Replace BMS; 2. Replace the battery pack.
Battery pack Undervoltage protection	<ol style="list-style-type: none"> 1. Check the power supply cables between battery packs 2. Check if the battery pack is too old or damaged. 	<ol style="list-style-type: none"> 1. Replace the wiring harness. 2. Replace the battery pack.
Overcurrent protection during charging	<ol style="list-style-type: none"> 1. Check if there is any damage, loose contact, or short circuiting in the charging port or wiring, 2. Check if the BMS board is functioning properly, 	<ol style="list-style-type: none"> 1. Replace the wiring harness. 2. Replace BMS
Overcurrent protection during discharging	<ol style="list-style-type: none"> 1. Check for sudden increases in load while the battery is in use. 2. Check the SOH of the battery. Damage, aging, or faults in internal battery components may lead to an increase in internal resistance. 3. Check if the temperature of the battery pack itself and the ambient temperature are normal. 4. Check if the BMS board is functioning properly, 	<ol style="list-style-type: none"> 1. Replace BMS; 2. Replace the battery pack.
High-temperature protection during charging	<ol style="list-style-type: none"> 1. Check for instances of rapid high-current charging. 2. Check for instances of prolonged charging. 3. Check the ambient temperature of the battery pack. 4. Check if the battery pack is too old or damaged. 	<ol style="list-style-type: none"> 1. Control or reduce the charging current. 2. Ensure that the battery pack is at a reasonable ambient temperature. 3. Replace the battery pack.
Low-temperature protection during charging	<ol style="list-style-type: none"> 1. Check the ambient temperature of the battery pack. 2. Check the heating current. 	<ol style="list-style-type: none"> 1. Ensure that the battery pack is at a reasonable ambient temperature.
High-temperature protection during discharging	<ol style="list-style-type: none"> 1. Check for sudden increases in load while the battery is in use. 2. Check if the battery pack is over-discharged. 3. Check the ambient temperature of the battery pack. 	<ol style="list-style-type: none"> 1. Ensure the stability of the load connection. 2. Ensure that the battery pack is at a reasonable ambient temperature. 3. Replace the battery pack.
Low-temperature protection during discharging	<ol style="list-style-type: none"> 1. Check for instances of rapid high-current discharging. 2. Check the ambient temperature of the battery pack. 3. Check the SOH of the battery pack 	<ol style="list-style-type: none"> 1. Ensure that the battery pack is at a reasonable ambient temperature. 2. Replace the battery pack.

Problem Description	Analysis Method	Measures
Protection against excessively large cell voltage difference	<ol style="list-style-type: none"> 1. Check if the voltage acquisition wiring harness is functioning properly. 2. Measure cell voltages using a multi-meter. 3. Verify if the BMS board's balancing function is normal. 	<ol style="list-style-type: none"> 1. Replace the wiring harness. 2. Replace the battery pack.
Protection against excessive temperature difference	<ol style="list-style-type: none"> 1. Check the ambient temperature of the battery pack. 2. Check the temperature acquisition wiring harness 3. Check if the battery cell is damaged. 	<ol style="list-style-type: none"> 1. Ensure that the battery pack is at a reasonable ambient temperature. 2. Replace the battery pack.
MOS high temperature protection	<ol style="list-style-type: none"> 1. Check the ambient temperature of the battery pack. 2. Check the charging and discharging currents. 	<ol style="list-style-type: none"> 1. Replace BMS
OCD1	Level 1 overcurrent protection during discharging	
OCD2	Level 2 overcurrent protection during discharging	
AFE UV	AFE undervoltage fault	
AFE OV	AFE overvoltage fault	
OCDL	Discharging overcurrent latch	
OCC	Overcurrent protection during charging	
SCD	Short circuiting protection during discharging	
SCDL	Permanent failure of discharging short circuiting latch	
AFE communication failure	<ol style="list-style-type: none"> 1. Check if there are any signs of burning on the AFE pins. 2. Check if there are any signs of burning on the BMS board. 3. Measure if the AFE communication pins have communication signal levels. 	<ol style="list-style-type: none"> 1. Restart the system 2. Replace BMS board
MOSFET short circuiting	<ol style="list-style-type: none"> 1. Check whether there is a transient overvoltage, overcurrent event, and electromagnetic interference 2. Check the temperature of the battery pack 	<ol style="list-style-type: none"> 1. Replace the BMS board
EEPROM fault	<ol style="list-style-type: none"> 1. Check if there are any signs of burning on the BMS board. 2. Check if there is electromagnetic interference in the environment. 3. Open the LAN host computer, read all BMS parameters, and check if the reading is successful. 	<ol style="list-style-type: none"> 1. If unable to read, then replace the BMS board. 2. If able to read successfully, then restart.
Internal communication failure	<ol style="list-style-type: none"> 1. Check whether the connection of the communication wiring harness is loose 2. Check whether the battery pack starts up and runs normally 	<ol style="list-style-type: none"> 1. Replace the wiring harness.
Host address duplication	<ol style="list-style-type: none"> 1. Check if the DI DO connections are correct. 	<ol style="list-style-type: none"> 1. Adjust the connected wiring harness. 2. Restart the master first and then restart the slave
Abnormal heating	<ol style="list-style-type: none"> 1. Check whether the heating MOS is stuck or if it has trouble switching 2. Check whether the heating time is too long 	<ol style="list-style-type: none"> 1. Replace BMS
Pre-charge failure	<ol style="list-style-type: none"> 1. Check if the pre-charge MOS is stuck and having trouble closing/opening properly. 	<ol style="list-style-type: none"> 1. Replace BMS
Reverse connection for charging	<ol style="list-style-type: none"> 1. Check the positive and negative connections . 	<ol style="list-style-type: none"> 1. Reconnect the wiring harness correctly

Problem Description	Analysis Method	Measures
Fuse blown fault	1. Check whether the cell voltage is greater than 4.1V 2. Check for MOS short-circuiting fault and the following faults triggered at the same time: Voltage acquisition line disconnected Temperature acquisition line disconnected AFE communication fault Temperature acquisition fault Cell voltage acquisition fault AFE fault information Charging reverse connection fault Maximum cell voltage exceeding 3.8V Cell volt high level 2 Maximum cell temperature exceeding 65°C Minimum cell temperature reaching 0°C MOS temperature exceeding 100°C	1. Replace BMS

10. After-sales Service

During the use of the product, according to the normal operation of the user manual can not Discharge the fault, please contact the dealer in time, and give clear feedback to the after-sales personnel: product model, purchase date, contact phone number, fault phenomenon.

1. Limited warranty, refer to the relevant warranty statement for details. In order to determine the date of purchase, consumers are asked to save the purchase of relevant bills and online shopping records.

2. During the warranty period, due to the damage caused by the product process or materials and non-human reasons, the company under takes free maintenance and parts replacement obligations.

3. The following conditions are not covered by the warranty:

- ① Unauthorized disassembly and maintenance;
- ② Product performance failure due to human reasons;
- ③ Damage caused by irresistible factors such as natural disasters, lightning, accidents;
- ④ Appearance damage after use is not covered by warranty;

11. Disposal

Observe applicable regulations on waste battery disposal. Immediately stop the use of damaged batteries. Please contact your installer or sales partner before disposal. Ensure that the battery is not exposed to moisture or direct sunlight.



Attention:

1. Do not dispose of batteries and rechargeable batteries as domestic waste! You are legally obliged to return used batteries and rechargeable batteries.
2. Waste batteries may contain pollutants that can damage the environment or your health if improperly stored or handled.
3. Batteries also contain iron, lithium and other important raw materials, which can be recycled.



12. EU Declaration of Conformity



within the scope of the EU directives

- Radio Equipment Directive 2014/53/EU (RED)
- Restriction of the use of certain hazardous substances 2011/65/EU (RoHS)

NINGBO DEYE INVERTER TECHNOLOGY CO., LTD. confirms herewith that the products described in this document are in compliance with the fundamental requirements and other relevant provisions of the above mentioned directives. The entire EU Declaration of Conformity and certificate can be found at <https://www.deyeinverter.com/download/#balcony-energy-storage>.



250217001
www.deyeinverter.com

EU Declaration of Conformity

Product: **All-in-one Balcony Energy Storage System**

Models: AE-FS2.0-2H2; AE-FS1.0-1H2; SUN-BK60-2.0KWH-EU-AM2; SUN-BK80-2.0KWH-EU-AM2;
SUN-BK100-2.0KWH-EU-AM2; SUN-BK60-1.0KWH-EU-AM2; SUN-BK80-1.0KWH-EU-AM2;
SUN-BK100-1.0KWH-EU-AM2;

Name and address of the manufacturer: Ningbo Deye Inverter Technology Co., Ltd.
No. 26 South Yongjiang Road, Daqi, Beilun, NingBo, China

This declaration of conformity is issued under the sole responsibility of the manufacturer. Also this product is under manufacturer's warranty.

This declaration of conformity is not valid any longer: if the product is modified, supplemented or changed in any other way, as well as in case the product is used or installed improperly.

The object of the declaration described above is in conformity with the relevant Union harmonization legislation: The restriction of the use of certain hazardous substances (RoHS) Directive 2011/65/EU and the Radio Equipment Directive (RED) 2014/53/EU.

References to the relevant harmonized standards used or references to the other technical specifications in relation to which conformity is declared:

EN 62109-1:2010	●
EN 62109-2:2011	●
EN IEC 61000-6-1:2019	●
EN IEC 61000-6-2:2019	●
EN IEC 61000-6-3:2021	●
EN IEC 61000-6-4:2019	●
EN IEC 61000-3-2:2019+A1:2021	●
EN 61000-3-3:2013/A2:2021/AC:2022-01	●
EN IEC 61000-3-11:2019	●
EN 61000-3-12:2011	●
EN 55011:2016/A2:2021	●
EN 300328 V 2.2.2:2019	●
EN 301489-1 V 2.2.3:2019	●
EN 301489-17 V 3.2.4:2020	●
EN 62920:2017+A11+A1	●
EN IEC 62311:2020	●
CISPR 11:2015+A1+A2	

Nom et Titre / Name and Title:

Bard Dai

Au nom de / On behalf of:

Senior Standard and Certification Engineer

Date / Date (yyyy-mm-dd):

Ningbo Deye Inverter Technology Co., Ltd.
2025-02-17

A / Place:

Ningbo Deye Inverter Technology Co., Ltd.
No. 26 South Yongjiang Road, Daqi, Beilun, NingBo, China

EU DoC - v2

13.Parameters and Specifications

Model	SUN-BK60-2.0KWH -EU-AM2	SUN-BK80-2.0KWH -EU-AM2	SUN-BK100-2.0KWH -EU-AM2
AC Technical Specification			
Nominal Input/Output Power/UPS Power	600W	800W	1000W
AC Inoput/Output Frequency and Voltage	50Hz(45Hz-55Hz),60Hz(55Hz-65Hz),L/N(PE),220/230 Va.c.		
Grid type	Single phase		
Rated Grid input/output Current	2.8/2.7A	3.7/3.5A	4.6/4.4A
Max.Grid input/output Current	3.0/2.9A	4.0/3.9A	5.0/4.8A
Peak Power(off grid)	2 time of rated power,10s		
Power Factor Adjustment Range	0.8 leading to 0.8 lagging		
Max. bypass(Gird to load)	10A		
DC injection current	THD<3%(Linear load<1.5%) mA		
DC Technical Specification			
Max.PV Access Power	1320W	1760W	2200W
Max.PV Input Power	960W	1280W	1600W
Max.PV Input Voltage	60V		
Start-up Voltage	25V		
MPPT Voltage Range	20~55V		
Full Load MPPT Voltage Range	28~55V	30~55V	35~55V
Rated PV Input Voltage	42.5V		
Max. Input Short Circuit Current	27+27A		
Max. Operating PV Input Current	18+18A		
No.of MPP Trackers/ No.of Strings	2/1+1		
Battery Technical Specification			
Battery Chemistry	LiFePO ₄		
Battery Nominal Voltage	51.2V		
Battery Nominal Energy	2000Wh		
Max.Charging/Discharging Current	25A		
Battery Operating Voltage	44.8V~57.6V		
Battery Cycle Life	≥6,000(@25°C±2°C,0.5C/0.5C,70%EOL)		
USB Port Technical Specification			
USB-A Output	2 ports, 5V, 2.4A, 12W Max per port		
USB-C Output	2 ports, 5V, 3.0A, 15W Max per port		
Other Technical Specification			
Display	Colorful Touch LCD &APP&Battery LED (SOC, Alarm)		
Communication interfaces	Wifi, Bluetooth,Lora		
Dimension(W×D×H)	450×210×321mm		
Weight Approximate	26kg		
Operating Temperature Range	-10°C~50°C(>45°C derating)		
Max.operating altitude	2000m		
Relative Humidity	0%~95%(No Condensing)		
Safety EC/Standard	IEC62619,UN38.3,IEC/EN 62109-1,IEC/EN 62109-2,IEC/EN 61000-6-1, IEC/EN 61000-6-2,IEC/EN 61000-6-3IEC/EN 61000-6-4		
Grid Regulation	VDE4105,IEC61727/62116,VDE0126,AS4777.2,CEI0 21,EN50549-1,G98, G99,C10-11,UNE217002,NBR16149/NBR16150		
Battery Certification	UN38.3,IEC62619		
Installation Style	Floor-Mounted		

NINGBO DEYE INVERTER TECHNOLOGY CO., LTD.

Add. : No.26 South YongJiang Road, Daqi, Beilun, NingBo, China.

Tel. : +86 (0) 574 8622 8957

Fax. : +86 (0) 574 8622 8852

E-mail. : service@deye.com.cn

Web. : www.deyeinverter.com



30240301004314