

Data Logger Quick Guide

Model:DL1000B-WIFI
V1.0

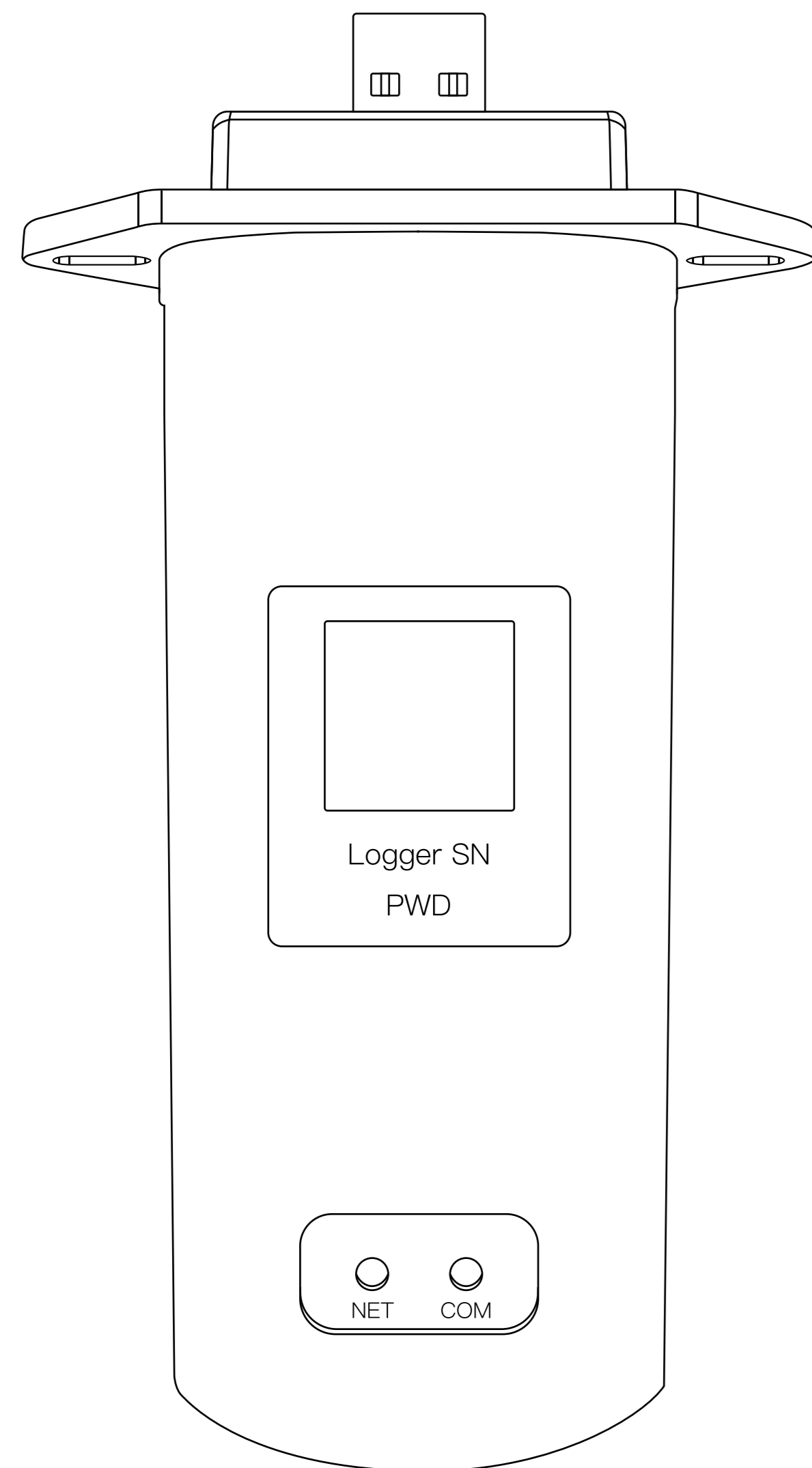

Disclaimer:

Please read this manual carefully before using products and keep it in the place where O&M providers can easily find.

Due to product upgrade and other factors, the content of this manual might change from time to time. Please take actual product as standard and get latest manual from www.deyecloud.com or sales. Unless otherwise agreed herein, this manual will only be used as guidance. Any statement, information or suggestion in this manual will not take any form of responsibility.

Without written permission, any content of this document (partly or entirely) cannot be extracted, copied or transmitted in any form by any company or individual.

Product Introduction

1 Data Logger Installation

Assemble logger to the inverter communication interface as shown in the diagram.

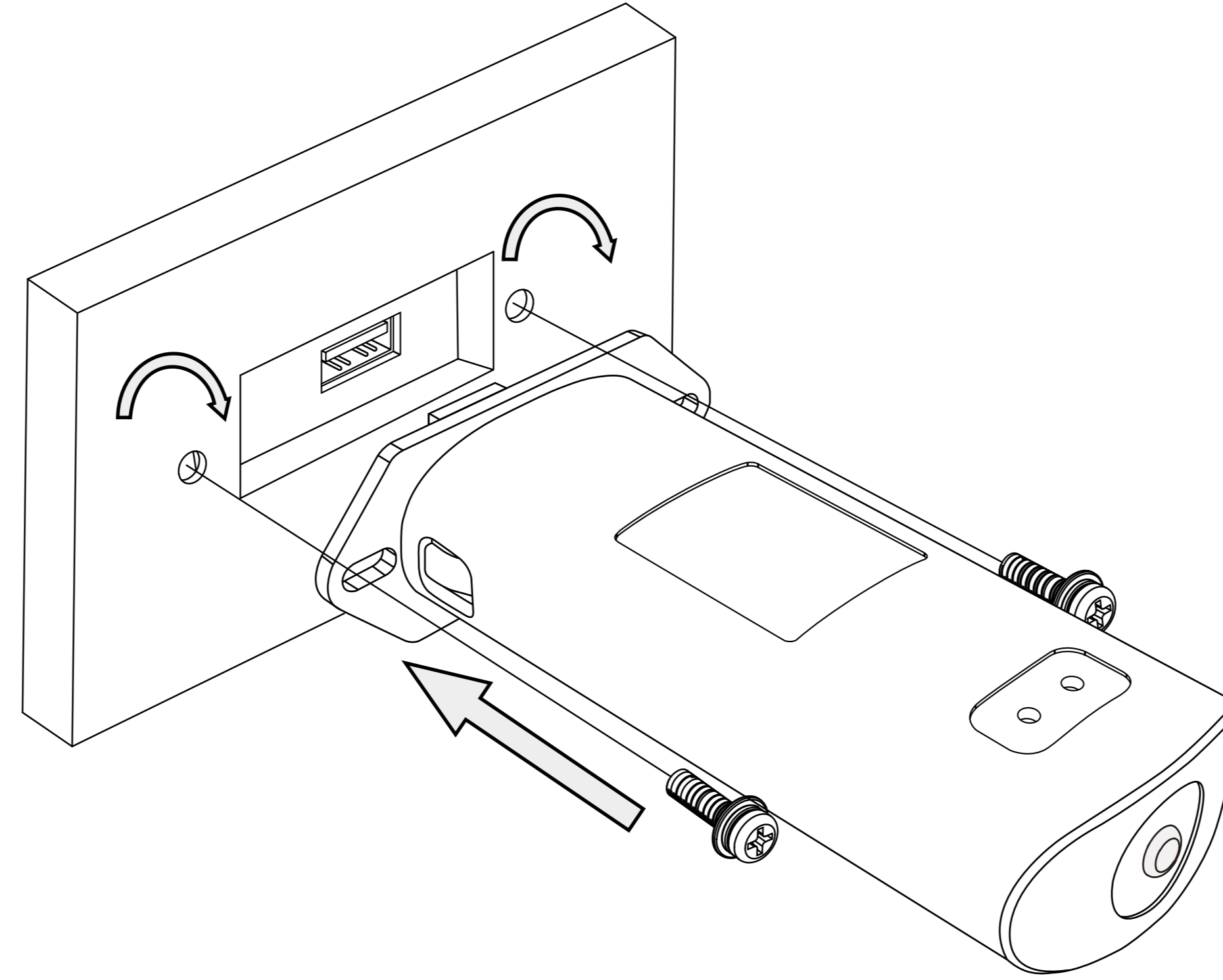

2 Logger Status

Lights	Implication	Status Description (Both lights are red/blue lights.)
● NET	Communication status with server	<ol style="list-style-type: none"> 1. Light off: connection to the cloud server failed. 2. Blue light on: connection to the cloud server succeeded. 3. Blue light flashing: connecting to the cloud server / logger OTA running. 4. Blue light flashing slowly: connection to the router succeeded. 5. Red light on: connection error.
● COM	Communication status with inverter	<ol style="list-style-type: none"> 1. Light off: power off. 2. Blue light on: connection to the device succeeded. 3. Blue light flashing: subdevice OTA running. 4. Blue light flashing slowly: power on 5. Red light on: connection error.
● + ● NET COM	Restore the factory settings	NET blue light flashing, and COM Blue light flashing: restoring factory settings.

The normal operation status of the data logger, when router connected to the network normally:

1. Connection to the server succeeded: NET blue light keeps on.
2. Connection to the device succeeded: COM blue light keeps on.

3 Abnormal State Processing

If the data on platform is abnormal when the data logger is running, please check the table below and according to the status of indicator lights to complete a simple troubleshooting. If it still can not be resolved or indicator lights status do not show in the table below, please contact Customer support. (Note: Please using the following table query after power-on for 2mins at least.)

● NET	● COM	Description	Possible Reason	Recommended Process
Red light flashing slowly	Any	Communication between data logger and cloud abnormal	<ol style="list-style-type: none"> 1. Network congestion 2. Wireless signal unstable 	<ol style="list-style-type: none"> 1. Check router network 2. Check wireless signal strength 3. Contact customer service
Red light on	Any	Communication between data logger and cloud abnormal	<ol style="list-style-type: none"> 1. Network limited 2. The cloud address connected by the data logger has changed 	<ol style="list-style-type: none"> 1. Check router network 2. Contact customer service

● NET	● COM	Description	Possible Reason	Recommended Process
Any	Red light flashing slowly	Communication between data logger and inverter abnormal	<ol style="list-style-type: none"> 1. Connection between data logger and inverter loosen 2. Electromagnetic interference causes data transmission error 	<ol style="list-style-type: none"> 1. Check connection between data logger and inverter, unplug and reinstall 2. Long press Reboot button for 5s to reboot data logger 3. Check if there are high power electrical appliances nearby
Any	Red light on	Communication between data logger and inverter abnormal	<ol style="list-style-type: none"> 1. Connection between data logger and inverter loosen 2. Communication rate between inverter and data logger does not match 	<ol style="list-style-type: none"> 1. Check connection between data logger and inverter, unplug and reinstall 2. Check if inverter's communication rate matches data logger 3. Long press Reboot button for 5s to reboot data logger

Safety Precautions

Warning

- 1 Please remove logger after power off.

- 2 Please do not hold the logger body to rotate while install or remove the logger.

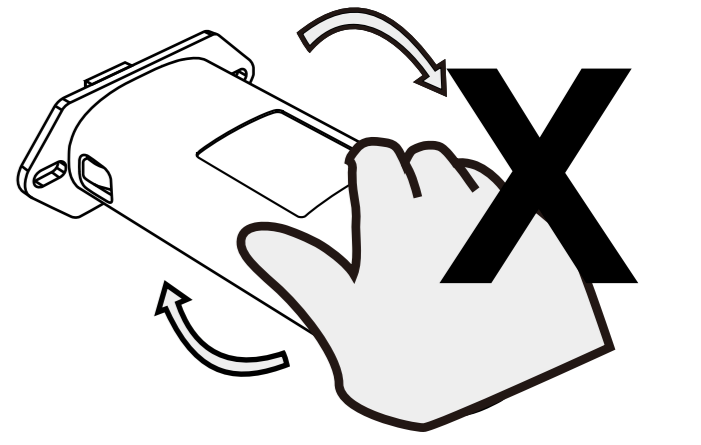

Notice

- 1 Do not remove Waterproof plug.

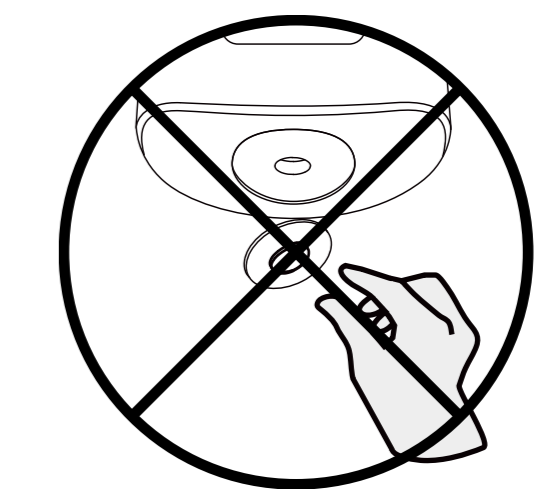

- 2 Please make sure the data logger is working properly before you leave the site. If there is anything abnormal, please do not leave the site and contact customer service at the first time.

- 3 5G WiFi is not supported.

Press	Key-press	Status Description	Light Status
	Long press 5s then release	Reboot the data logger.	All lights are extinguished immediately.
	Long press 10s then release	Resetting the data logger.	<ol style="list-style-type: none"> 1. All lights are extinguished after 4s. 2. COM light flashes fast for 100ms.

Deye Cloud APP

Download APP



DeyeCloud APP
Please scan QR code to download DeyeCloud APP.

Or you can log in to <https://deyecloud.com/>

USER MANUAL for Deye Cloud APP

Please make sure Bluetooth and WiFi are ON and the router can connect to the internet normally.

1 Registration

Go to Deye Cloud App and register. Click "Register Account" and create your account here.

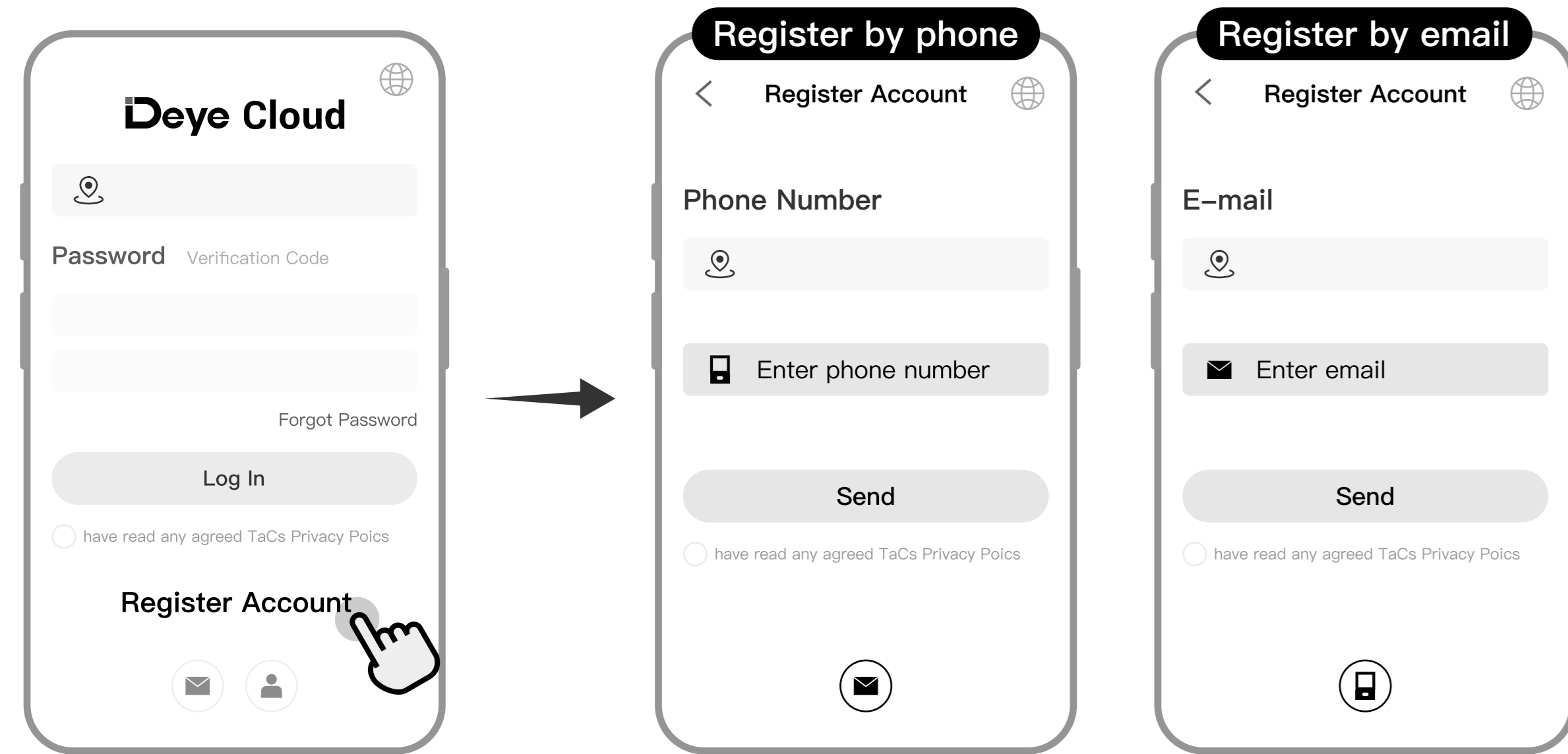

2 Create a Plant

1. Click "Create a Plant" to create your plant.
2. Please fill in plant info here.

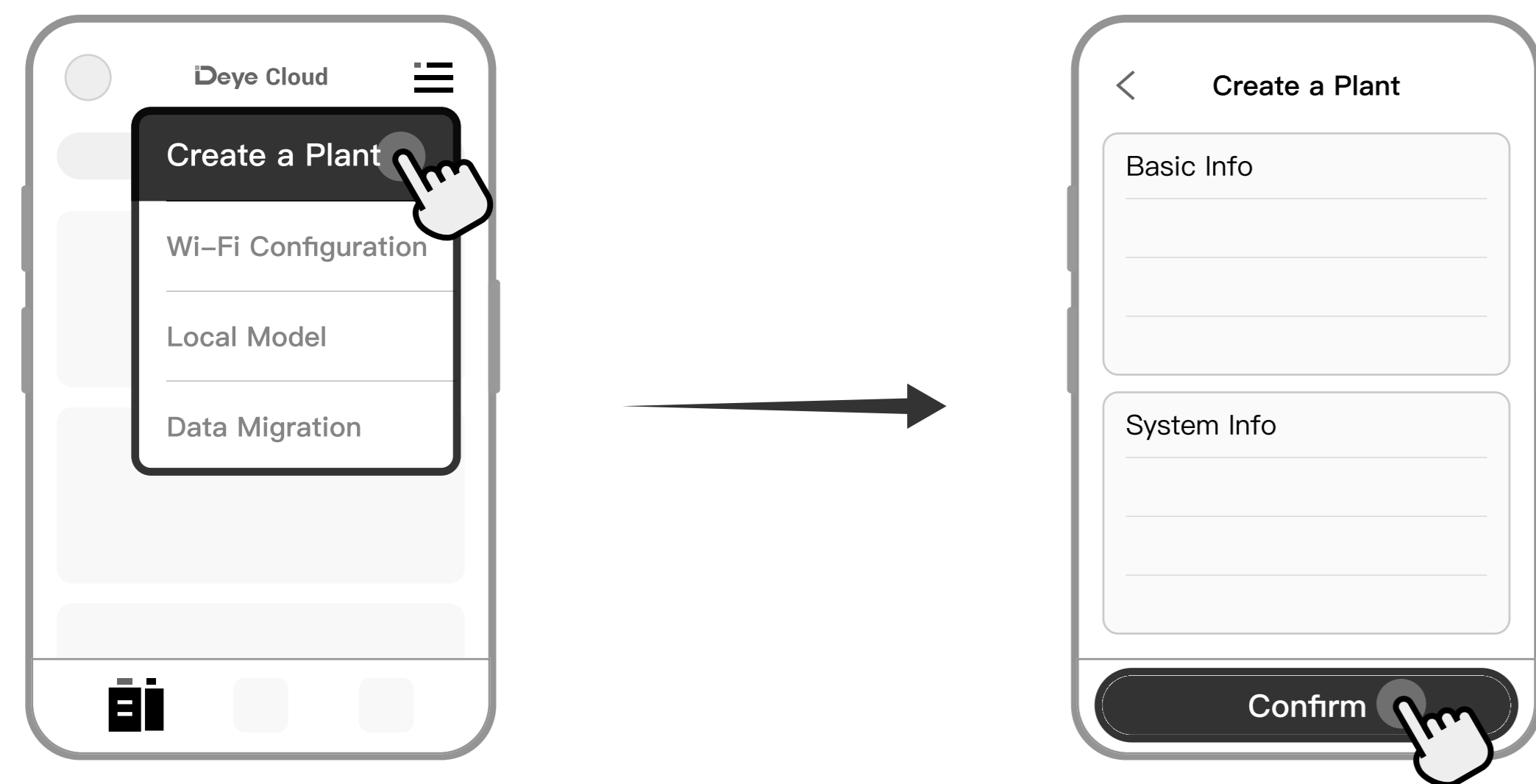

3 Add a Logger

1. Choose a Plant.
2. Go to "Device" page and click on "Add a Logger".
3. Scan QR code of the logger, which can be found on the logger body.

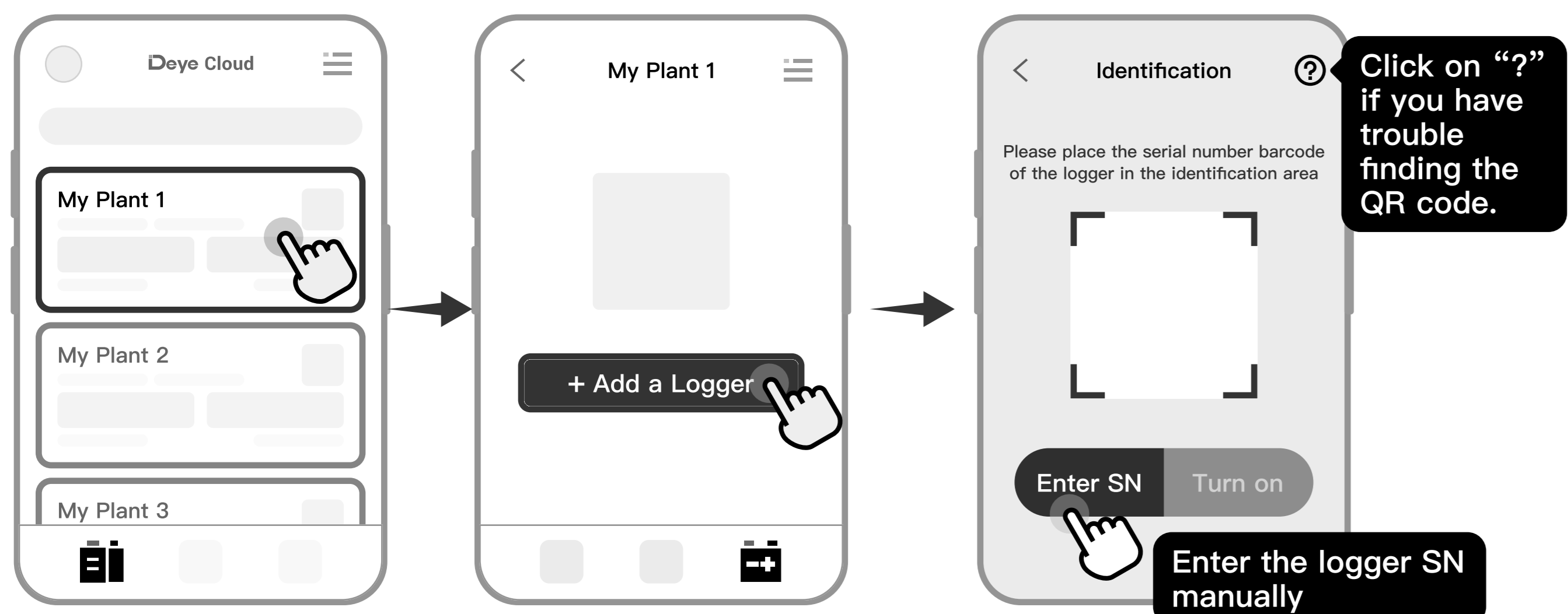

WiFi Configuration

Use APP to Configure WiFi

1. Click "Wi-Fi Configuration" to set the network. (Please make sure Bluetooth and WiFi are ON.)
2. Please wait for a few minutes. Then select "Data Logger SN" and connect 2.4G WiFi.

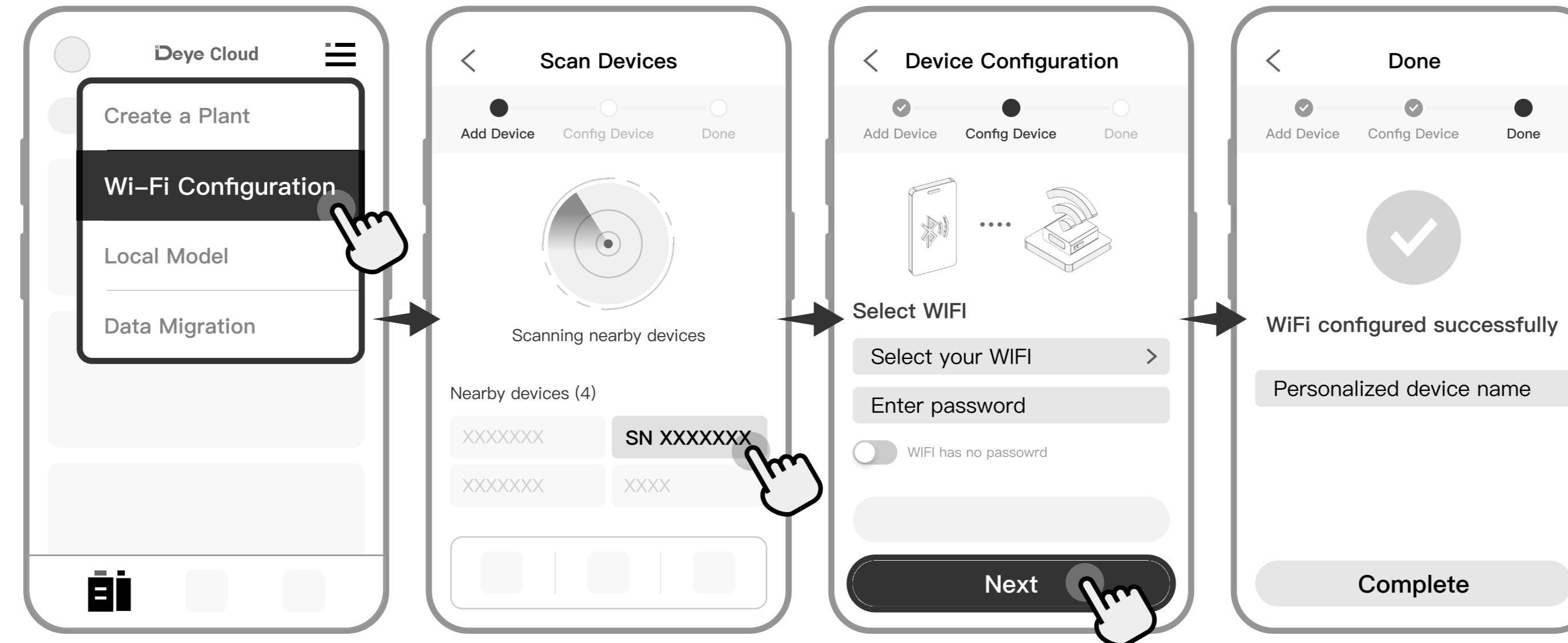

Use the Web Page to Configure WiFi

1 Connect to the device WiFi

1. Connect the phone/computer to the WiFi with the name DXXXXXXXXXX(Logger SN).

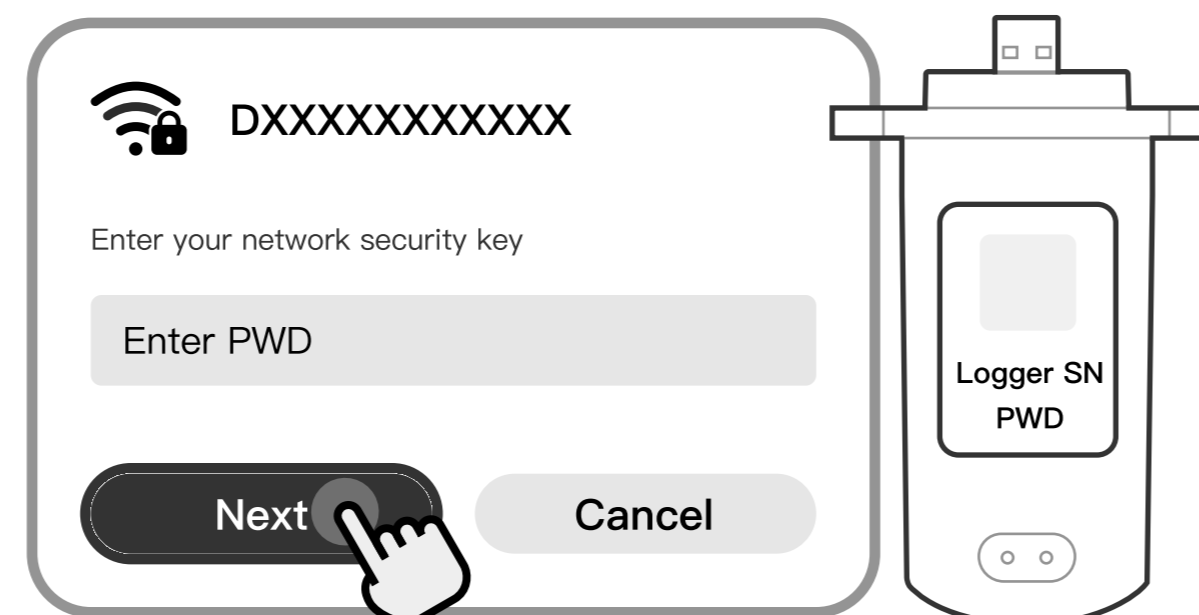

2 Login to the web page

1. Enter following IP address on the web page: 10.10.100.254.
2. Set up user name + password and login.

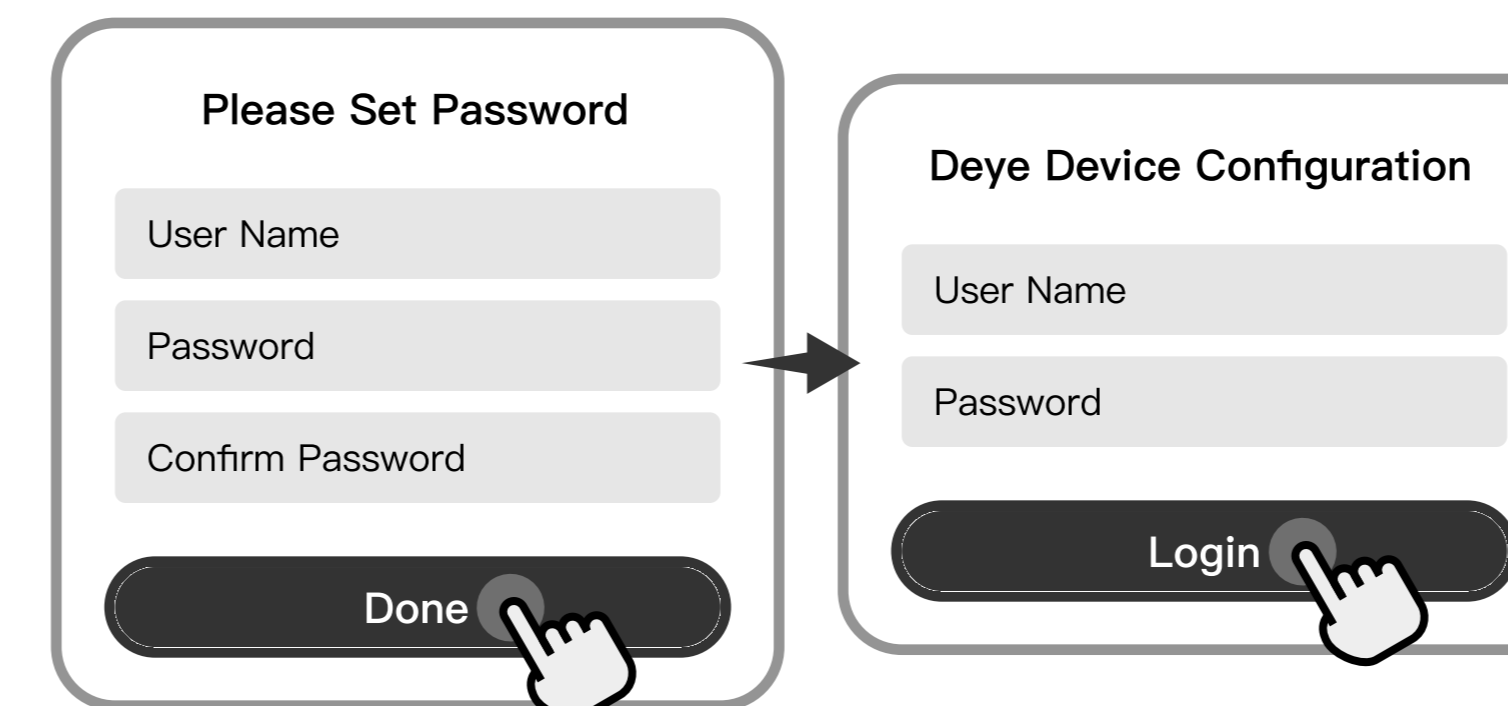

3 Set up WiFi

Click on "Wireless Settings", select the WiFi to connect.

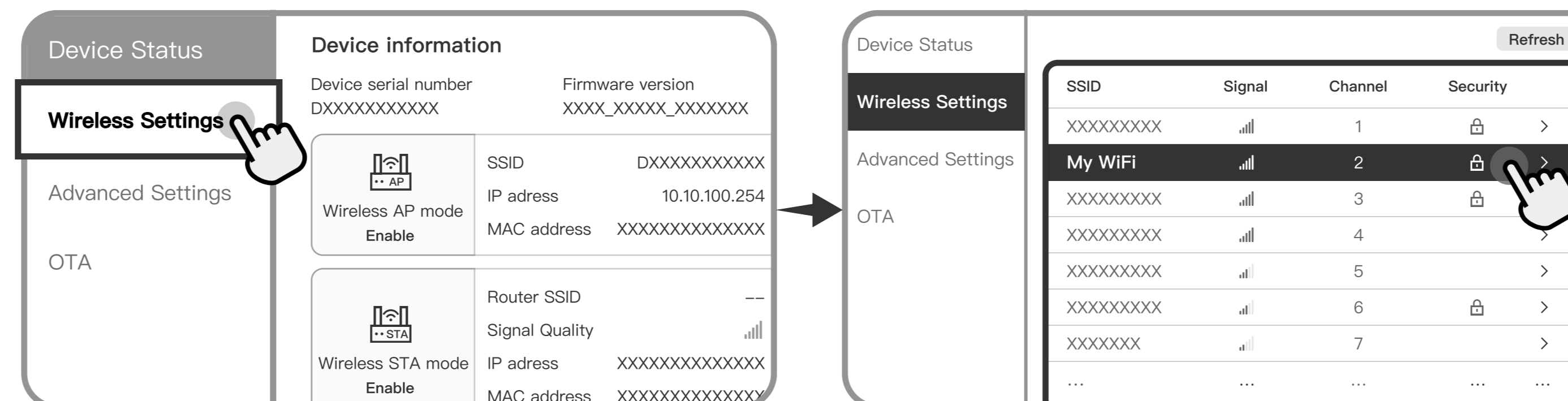

4 Enter WiFi password

Enter the password and Click "Confirm" to complete the WiFi setup.

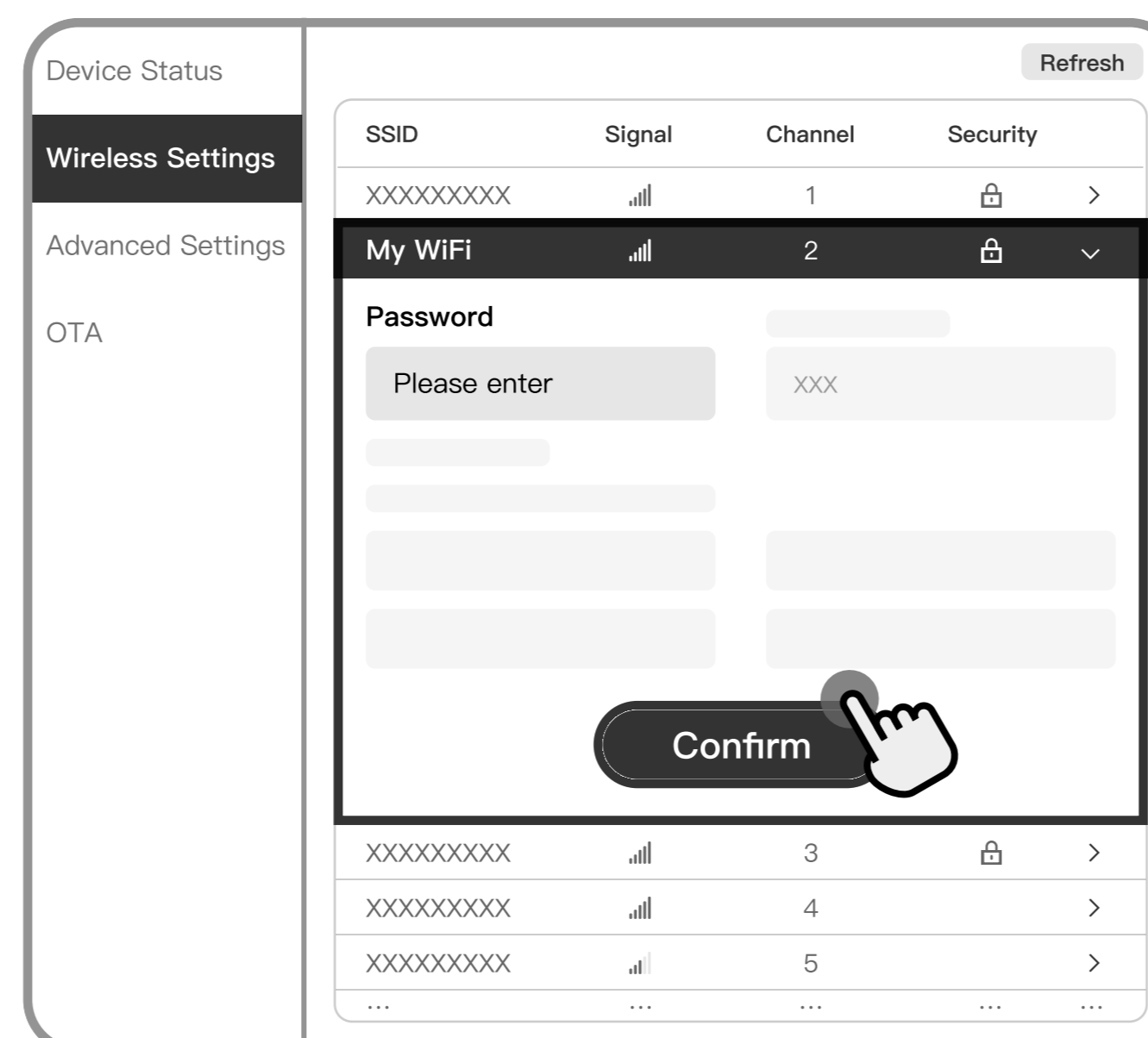

5 Check WiFi configuration status

If the WiFi is successfully configured, the device information page will show wireless status as "Enable" and Cloud server status as "Connected".

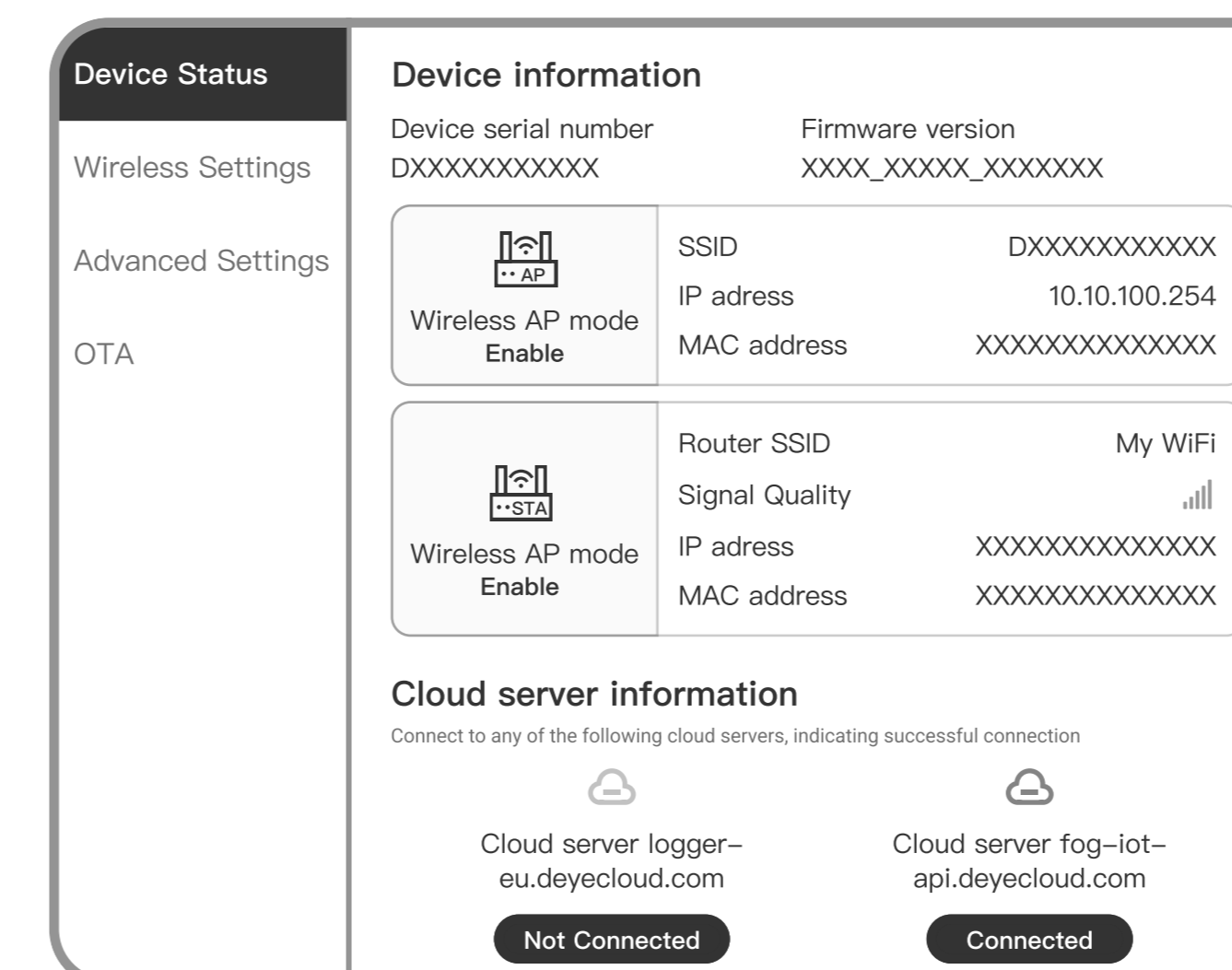

Warranty Card

Dear Customers,

Thank you very much for using our products. In order to provide you with better service, please fill in the warranty card and reserve it carefully.

Filled in by the customer:

User Name		Customer Name	
Purchase Date		Customer Phone	
Product Name & Model		Product SN	
Customer Address			
Order No.			
Maintenance Records	Data	Failure Cause and Treatment	

Warranty Policy

If there is any breakdown which caused by the product's own quality, customers can send the warranty card with the product to our Customer Service Center.

1. According to the prescription, the warranty period is 5 years(From the day when you receive the product). During the warranty period, we provide free maintenance service to solve all non-artificial quality problems if the product is under normal usage circumstance. If the product exceeds the warranty period, only maintenance cost will be charged.
2. If the failure of the product is not due to quality problems (such as improper use, improper storage, unauthorized disassembly, etc.) , maintenance cost will be charged.

3. Please pay for back freight in advance. Freight collect is not accepted.

Contact

Email: service@deye.com.cn

Tel: +86 (0) 574 8622 8957

Add: No.26-30, South Yongjiang Road, Beilun, 315806, Ningbo, China