



Photovoltaic Grid-connected Microinverter (Built-in Wi-Fi G4)

SUN-E60G4-EU-Q0

SUN-E80G4-EU-Q0

SUN-E100G4-EU-Q0

SUN-E110G4-EU-Q0

User Manual

Contents

1. Instructions and Compliance	- 01 -
1.1 Safety Instructions	- 01 -
1.2 Radio Interference Statement	- 02 -
1.3 Meaning of Symbols	- 03 -
2. System Introduction	- 04 -
2.1 Product Introduction	- 04 -
2.2 System Highlights	- 04 -
3. Installation Guidance	- 05 -
3.1 Installation Tools	- 05 -
3.2 Installation Steps	- 06 -
3.3 Wiring Diagrams	- 10 -
4. Operation Instructions	- 12 -
4.1 Start Operating	- 12 -
4.2 Status Indications and Error Reporting	- 12 -
4.3 Reasons for Not Operating	- 13 -
4.4 Resolutions for Not Operating	- 13 -
4.5 Microinverter Replacement	- 14 -
5. System Monitoring	- 15 -
5.1 Monitoring via Web Platform	- 15 -
5.2 Monitoring via Mobile App	- 27 -
6. Appendix	- 32 -
6.1 Technical Data	- 32 -
6.2 EU Declaration of Conformity	- 33 -

1. Instructions and Compliance

This manual contains important instructions that must be followed during installation and maintenance of the Photovoltaic Grid-connected Inverter (microinverter). To reduce the risk of electrical shock and ensure safe installation and operation of the microinverter, the following warning symbols are used in this document to indicate dangerous situations and important safety instructions.

Please be kindly noted:

- ✓ Specifications are subject to change without notice.
- ✓ Be sure to download the latest version of the manual from the manufacturer's official website www.deyeinverter.com.

WARNING: Indicate that failing to follow instructions appropriately may cause severe hardware damage or personnel injuries. Please take extra care when carrying out this task.

NOTE: Indicate important information for optimal microinverter operation. Please follow these instructions strictly.

CAUTION: INDICATE IMPORTANT INFORMATION THAT NEEDS TO BE READ CAREFULLY AND KEPT FOR EVENTUAL REQUESTS.

1.1 Safety Instructions

- ✓ **DO NOT** disconnect PV modules from the microinverter without disconnecting the AC power.
- ✓ Only qualified personnel can install and/or replace the microinverters.
- ✓ Please perform all electrical installations under local electrical codes.
- ✓ Please read all the instruction and precaution markings in the technical documents and on the microinverter and the solar array before installing or using the microinverter.
- ✓ Be aware that the body of the microinverter is the heat sink and can reach a temperature of 80°C. **DO NOT** touch the body of the microinverter to avoid being scalded.
- ✓ When the microinverter is working properly, please maintain a distance of at least 20cm from it.
- ✓ **DO NOT** try to repair the microinverter. If the device fails to work properly, please contact technical support to obtain an RMA number for replacement. Damaging or opening the microinverter will void the warranty.

✓ CAUTION!

- * The external protective earthing conductor is connected to the microinverter's protective earthing terminal through an AC connector.
- * For safe system connection, connect the AC connector first to ensure the inverter is grounded, and then carry out DC connections.
- * For safe system disconnection, turn off the circuit breakers of each branch to disconnect the AC power first. Remain the protective earthing conductor of the circuit breaker connected to the microinverter. Finally, disconnect the DC inputs.

✓ **DO NOT** connect DC inputs to the microinverter when the AC connector is unplugged in any circumstances.

✓ Please install isolation switches on the AC side of the microinverter.

1.2 Radio Interference Statement

The equipment may radiate radio frequency energy. If the instructions are not followed during installation and use of the equipment, it may cause harmful interference to radio communications. However, there is no guarantee that interference will not occur in a particular installation situation. If this equipment causes harmful interference to radio or television reception, the following measures can be taken to resolve the problem:

- ✓ Relocate the receiving antenna away from the equipment.
- ✓ Seek assistance from the distributor or an experienced radio/TV technician.

Changes or modifications not expressly approved by the party responsible for compliance may void the user's authority to operate the equipment.

Wi-Fi Information







Frequency range: 2.412~2.472GHz

Wi-Fi maximum transmitting power: 16dBm \pm 2dBm

Antenna: external

Antenna gain: 2.00dBi

1.3 Meaning of Symbols

Labels	Description
	Caution Risk of electric shock.
	Caution Risk of burn. Do not touch.
	Caution Hot surface.
	Treatment A compliance with European Directive 2002/96/EC on Waste Electrical and Electronic Equipment. Indicate that the device, accessories, and packaging must not be disposed of as unsorted municipal waste and require separate collection at end-of-life. Please comply with local disposal regulations or consult the manufacturer's authorized distributor for equipment decommissioning guidance.
	CE Mark Attached to verify that the equipment complies with the requirements of the European RED Directives.
	Please refer to the operating instructions.
Qualified personnel	It refers to individuals who can recognize dangers and avoid harm caused by electricity under the proper guidance or supervision of an electrical technician. In the context of safety information in this manual, "Qualified personnel" refers to those who are familiar with safety, refrigeration systems, and EMC requirements, and are authorized to energize, ground, and label equipment, systems, and circuits according to established safety procedures. Inverters and end systems can only be commissioned and operated by qualified personnel.

2. System Introduction

2.1 Product Introduction

The microinverter is widely applied to grid-tied scenarios with active interactions with the utility grid. To make sure the equipment operate normally, please refer to Section 6.1 technical data to check the PV string input data of microinverters and ensure they match with PV modules. This series microinverter has a built-in Wi-Fi module, so it can communicate with the router directly.

Inverter Model	SUN-E60/80/100/110G4-EU-Q0
PV Input Voltage	42.5V (20V~60V)
PV Array MPPT Voltage Range	25V~55V
No. of MPP Trackers	2
No. of Strings per MPP Tracker	1

NOTE: If the wireless signal is weak in the area where the microinverter is installed, a Wi-Fi signal booster should be added at an appropriate location between the router and the microinverter.

2.2 System Highlights

This integrated system improves safety, maximizes solar power generation, increases system reliability, and simplifies system design, installation, maintenance, and management.

✓ Maximizing Solar Power Generation

Each PV module is equipped with its own Maximum Power Point Tracking (MPPT) control, ensuring that the maximum power is delivered to the grid, regardless of how the other modules are performing. If some modules in the array are affected by factors like shade, dust, or orientation, causing them to underperform, the microinverter optimizes the performance of each individual module to ensure the overall array operates at its best.

✓ More Reliable than Centralized or String Inverters

The distributed microinverter system eliminates the risk of a single point of failure in the PV system. Microinverters are built to perform at full power even in outdoor environments with temperatures up to 113°F (45°C). The inverter enclosure is designed for outdoor use with IP67 protection rating.

✓ Easy Installation and Management

Users can install individual PV modules in any combination of quantity, orientation, type, and power rating. The ground wire (PE) of the AC cable connects directly to the microinverter chassis, possibly eliminating the need for a separate grounding wire (check local regulations).

Data collection is done via the built-in Wi-Fi, so a wireless router should be placed near the microinverter. Once the microinverter is installed, configure the router with the internal Wi-Fi (see the Wi-Fi user manual). The data will be uploaded automatically, and users can monitor and manage the microinverter through the web platform or mobile app.

3. Installation Guidance

A solar PV system with microinverters is easy to install. Each microinverter can be quickly mounted on the PV bracket, just under the PV module. Low-voltage DC cables connect the PV module directly to the microinverter. This design removes the risk of high DC voltage. Make sure the installation follows all local rules and technical requirements.

WARNING: Electrical work must follow local electrical codes.

WARNING: Only qualified personnel can install and/or replace the microinverters.

WARNING: Before installation or use, please read all instructions and warning labels on the Microinverter, PV system, and technical documents.

WARNING: There is a risk of electric shock during installation. Please take proper precautions.



NOTE: It is strongly recommended to install surge protection devices in the dedicated meter box.

NOTE: This equipment is suitable for residential, commercial and light industrial use. It is not suitable for heavy industrial environments.

3.1 Installation Tools

A. What's in the box

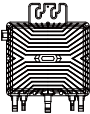
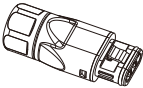
Refer to the following table and check if all necessary items are included in the package:

Picture	Item	Quantity
	Microinverter	1
	3-Core AC Male Connector	1
	User Manual	1

B. Necessary tools

Besides the PV array and its accessories, the following tools and materials are also needed:

- ✓ One or more AC connection junction boxes
- ✓ Mounting hardware that fits your solar panel bracket
- ✓ Sockets and wrenches for the mounting hardware
- ✓ Continuous grounding conductor and grounding washers
- ✓ A Phillips screwdriver
- ✓ A torque wrench

3.2 Installation Steps

Step 1. Install the AC branch circuit junction box

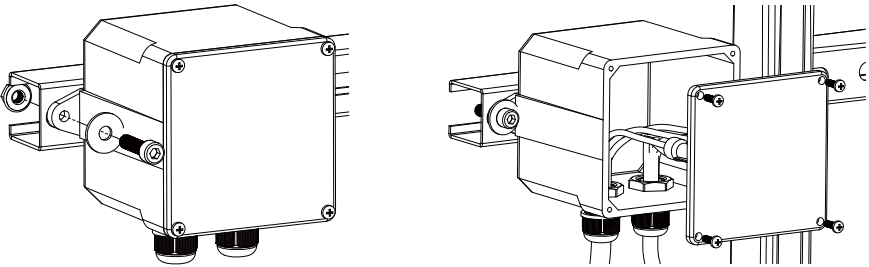

- A. Mount a junction box on the PV rack at a suitable place, usually at the end of a row of PV modules.
- B. Insert the open end of the AC cable into the junction box using a proper cable gland or strain relief.
- C. Connect the junction box to the grid connection point (usually inside a distribution box).

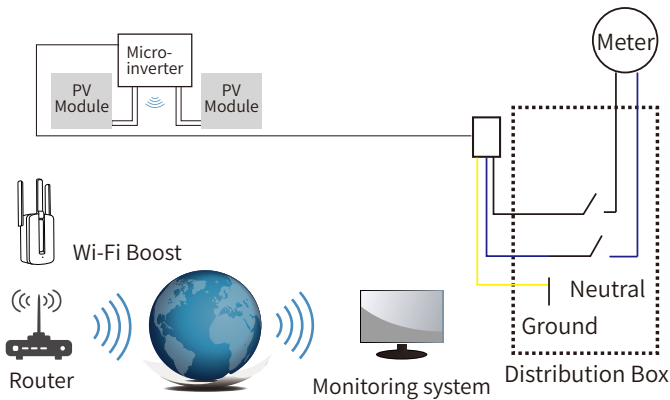

System Diagram - 2 MPPTs

WARNING: Wiring color codes may vary depending on local regulations, so always check all installation cables before connecting them to the AC cable to ensure they match correctly. Incorrect wiring can cause permanent damage to the microinverter, and such damage is not covered by the warranty.

WARNING: Please install AC breakers on the AC side of the microinverter.

Step 2. Mount the microinverters to the bracket or the PV module frame

- A. Mark where each microinverter will go on the bracket, making sure it's positioned well in relation to the PV module, junction box, and any other obstacles.
- B. Use mounting hardware approved by your bracket supplier to attach one microinverter at each marked spot.

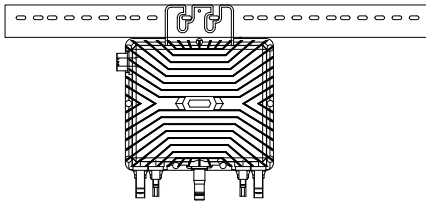

Mounting-E60/80/100/110 G4 (2 MPPTs)

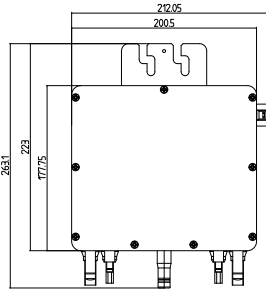

* The AC cable on the microinverter is a TC-ER type with a wire size of 1mm² (18AWG).

WARNING: Before installing any microinverters, make sure the grid voltage at the connection point matches the rated voltage shown on the microinverter label.

WARNING: Do not install the microinverters (including DC and AC connectors) in areas exposed to sun, rain, or snow—including gaps between modules. Leave at least 3/4 inch (1.5 cm) between the roof and the bottom of the microinverter for proper airflow.

Step 3. Connect the microinverter to the junction box

The 3-core AC male connector consists of four parts: socket, sleeve, sealing ring, and locking nut.

- ① Remove the sealing ring and sleeve from the AC male connector in order.
- ② As shown in the diagram below, separate the sleeve from the socket. There are two locking holes on the connector body—press the locking tabs inward to release the sleeve from the socket.

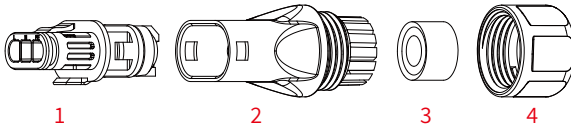

1. socket; 2. Sleeve; 3. Sealing ring; 4. Locking nut;
3-Core AC Male Connector Structure

- ③ Prepare the AC cable. Use a wire stripper to remove about 40mm of the outer sheath, then strip about 8–15mm of insulation from each conductor, as shown in the diagram.

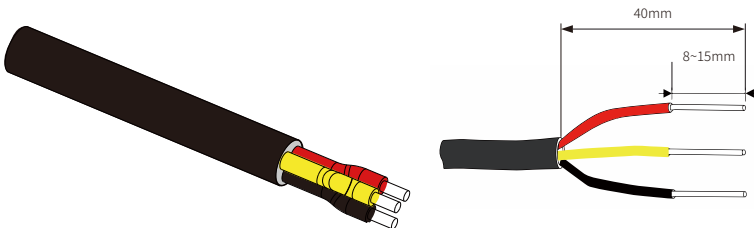

- ④ Insert the L (Live), N (Neutral), and PE (Ground) wires of the cable through the locking nut, sealing ring, and sleeve—in that exact order and direction.
- ⑤ Use an internal hex screwdriver to loosen the screws on the socket. Insert each wire into its corresponding terminal hole, then tighten all screws securely. Refer to the diagram below for correct wire placement in the connector.

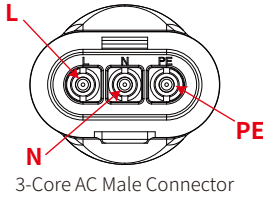

Inverter Model	Wire Size	Cable (mm ²)	Max. Torque Value	Max. Cable Length
SUN-E60/80/100/ 110G4-EU-Q0	12AWG	2.5	1.0Nm	Outside Cable (L+N+PE) 20m

⑥ Slide the sealing ring and sleeve along the wires until the sleeve clicks into place on the socket. Make sure the sealing ring fits tightly inside the sleeve around the wires. Finally, tighten the locking nut. The 3-core AC male connector is now ready to use.

⑦ Connect the prepared 3-core AC male connector to the microinverter and the open end to the N, L, and PE terminals in the junction box.

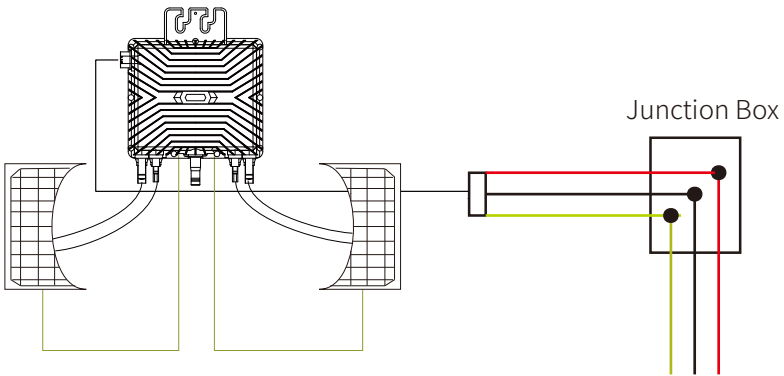

WARNING: Make sure the N, L, and PE wires are connected to the correct terminals. Incorrect wiring can lead to a system short circuit.

Step 4. Connect the PV modules to the microinverter

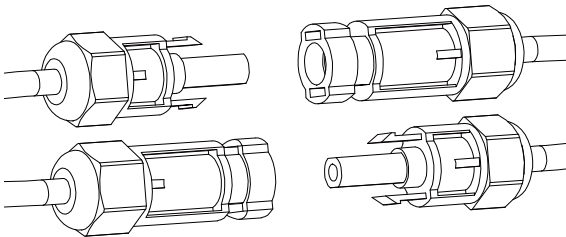

- A. Connect the PV modules to the DC input ports on the microinverter.
- B. To meet local regulations, the DC cable length must be less than 3 meters. Please check with your local power provider to ensure the DC cables meet local rules.

Inverter Model	Cross Section (mm ²)	
	Range	Recommended Value
SUN-E60/80/100/110G4-EU-Q0	2.5~4.0 (12~10AWG)	2.5 (12AWG)

NOTE: When plugging in the DC cables:

- ✓ If AC power is already available, the microinverter will blink in red and start working within the set time (60 seconds in default).
- ✓ If AC power is not available, the microinverter will blink red three times, pause for 1 second, then repeat until the AC power is available.

B. Sample Wiring Diagram of Three-Phase System

E60/80/100/110G4 (2 MPPTs)

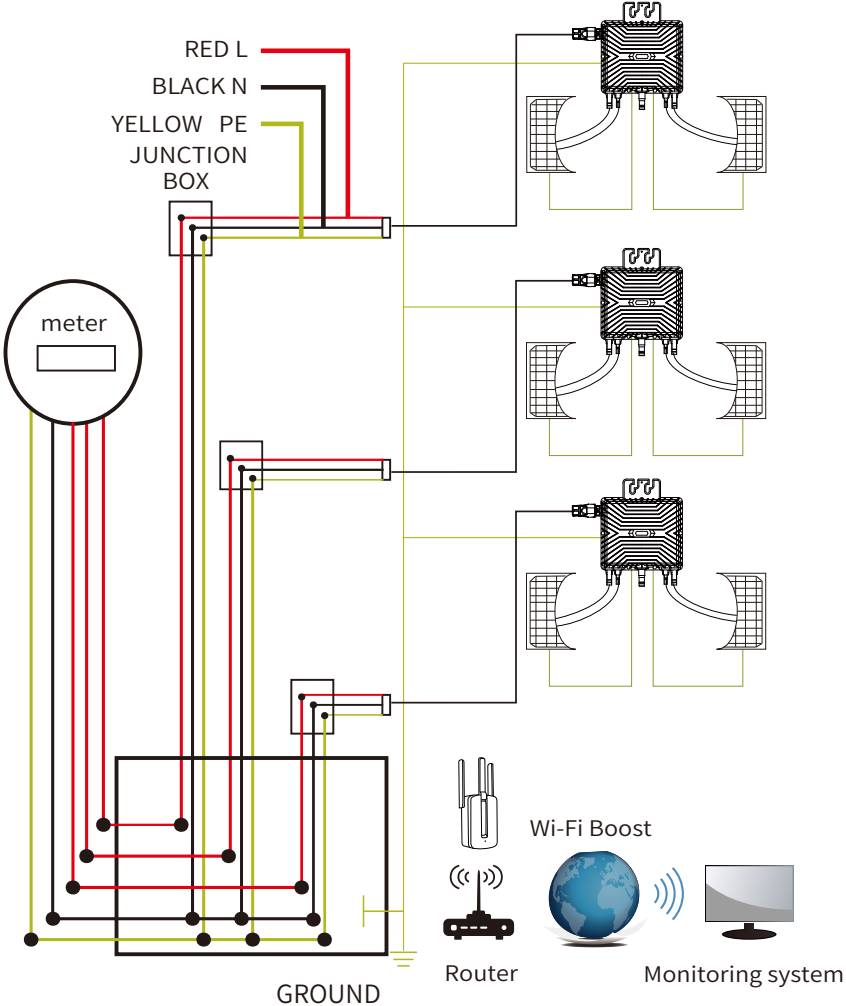

4. Operation Instructions

4.1 Start Operating

After a successful installation of the microinverter solar PV system, start the system operating by following the instructions:

Step 1. Turn ON the AC circuit breaker for each microinverter's AC branch circuit.

Step 2. Turn ON the AC circuit breaker for the grid.

Step 3. The microinverter will start blinking in red for about one minute and when it turns blue, it indicates that the microinverter is producing power normally. The faster the blue blinking is, the more power is generated.

Step 4. Configure the network of the microinverter based on instructions.

Step 5. The microinverter will send performance data to the router via the Wi-Fi module every 5 minutes. Users can monitor the performance of each microinverter through the website platform and mobile app.

NOTE: When AC power is connected but the microinverter has not started, a power meter may show about 0.1A current and 25VA for each microinverter. This is reactive power and is not actually consumed from the grid.

4.2 Status Indications and Error Reporting

Qualified personnel can do the following troubleshooting if the solar PV system does not operate normally.

Startup LED

About one minute after DC power is first applied to the microinverter:

- ✓ One short red blink indicates that the microinverter has started up successfully.
- ✓ Two or more short red blinks indicate a failure during the microinverter startup process.

Operation LED

LED Indicator	Status Description	Recommended Action
Slow Blue Blinking	Low Power Generation	If occurring under adequate sunlight, check for dust accumulation or shading on the PV modules.
Fast Blue Flashing	High Power Generation	Normal operation. No action required.

Error Reporting

LED Indicator	Status Description	Recommended Action
≥ 2 Short Red Blinks After Initial DC Power-On	Microinverter startup failure	Restart the microinverter. Verify that the PV input current is within the allowable range.
2 Red Blinks	DC under-voltage or over-voltage	Check whether the actual PV module voltage is within the specified operating range.

LED Indicator	Status Description	Recommended Action
4 Red Blinks	GFDI (Ground Fault Detector Interrupter) Error	Check whether the PV module frame is properly grounded.
7 Red Blinks	Grid failure	Check if the AC output circuit is properly connected. Verify that the grid voltage and frequency are within allowable limits.

WARNING: Do not disconnect the DC connectors while under load. Ensure that there is no current flowing through the DC cables before disconnection. To prevent current flow, an opaque material may be used to cover the PV module before disconnecting.

4.3 Reasons for Not Operating

If the microinverter is not operating normally, check the following guidance to find out the problem:

A. Problems with Microinverter

Check section 4.2 for detailed information.

B. Communication Problems Between the Microinverter and the Router

Indicate a situation where the microinverter itself is working normally but the communication between the microinverter and router is having problems. To quickly determine whether the issue lies with the microinverter or with the communication system, perform a diagnosis through the network:

- ✓ If no data is displayed on the web platform or mobile app, check the network configuration.
- ✓ If the microinverter is shown as online but no data is displayed, it may be due to the cloud platform server undergoing an update.

4.4 Resolutions for Not Operating

To troubleshoot a microinverter that is not operating normally, please follow the steps below:

Step 1. Verify that the grid voltage and frequency are within the ranges specified in the technical data (refer to section 6.1 in this manual).

Step 2. Check the connection to the grid. First, disconnect the AC power, then disconnect the DC power. Ensure that the grid voltage can be measured at the AC connector. Do not disconnect the DC cables while the microinverter is producing power. After that, reconnect the DC connectors and check LED light status.

Step 3. Check the AC branch circuit interconnections between all microinverters. Confirm that each microinverter is properly energized by the grid, as described in the last step.

Step 4. Ensure that all AC circuit breakers are functioning correctly and are in the closed position.

Step 5. Check the DC connections between the microinverter and the PV module.

Step 6. Verify that the DC voltage from the PV module is within the allowable range specified in the technical data (refer to section 6.1 in this manual).

Step 7. If the problem still exists, please contact us for technical support.

WARNING: Do not try to repair the microinverter. If troubleshooting steps do not resolve the issue, please contact the distributor or the Deye support team for assistance.

4.5 Microinverter Replacement

Step 1. Disconnect the microinverter from the PV Module

- ✓ Turn off the circuit breaker for each AC branch to disconnect the AC circuit.
- ✓ Disconnect the AC connector from the microinverter.
- ✓ Cover the PV module with an opaque material to block sunlight.
- ✓ Disconnect the DC connectors of the PV module from the microinverter.
- ✓ Remove the microinverter from the PV array racking.

Step 2. Replace with a new microinverter

- ✓ Install a new microinverter to the bracket step by step (refer to Section 3 Installation Guidance in this manual).
- ✓ Remove the opaque material used for blocking sunlight.
- ✓ Observe the LED light status immediately after the new microinverter is connected to the DC cables.

Step 3. Connect the AC cables of the new microinverter

5. System Monitoring

This series of microinverters comes with a built-in Wi-Fi module that allows for direct connection to the router. This feature enables users to remotely monitor and manage their solar system on Deye Cloud via web platform or mobile app. Follow the instructions to setup your plant.

5.1 Monitoring via Web Platform

5.1.1 Preparations

Step 1. Register and log in

* Enter <https://www.deyecloud.com/login> in browser and click "Register Account" at the bottom right of this page.

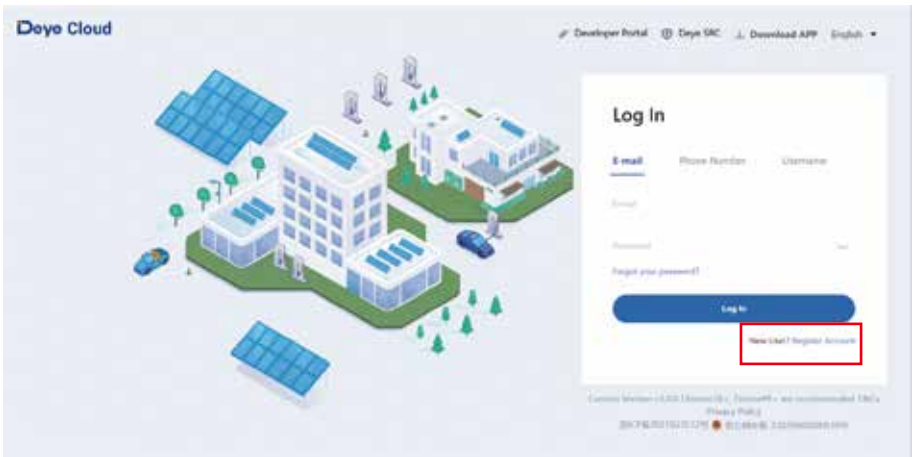

* Choose your identity as a residential or business user.

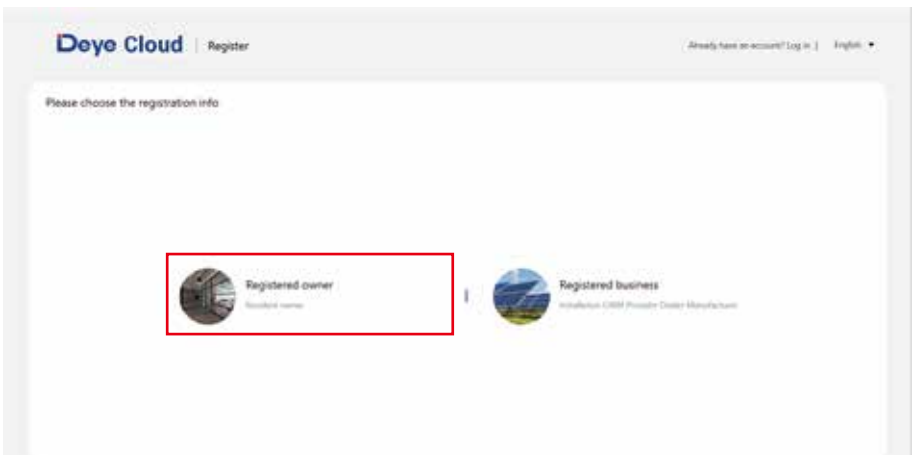

A. Residential user

* Enter the required information like email address, password, verification code, check "T&Cs and Privacy Policy" and click "Register" to create a new account.

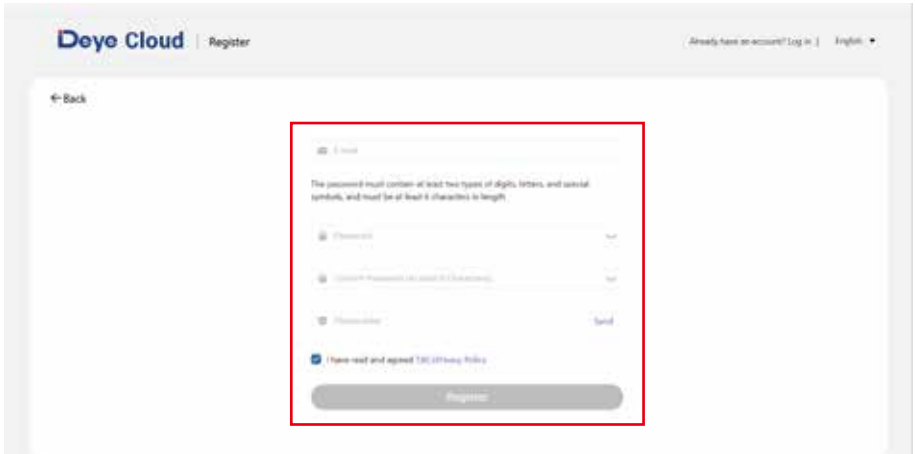

The screenshot shows the 'Deyo Cloud Register' page. A red box highlights the registration form fields. The form includes a 'Back' link, a password strength indicator, and a 'Register' button. The password requirements are: 'The password must contain at least two types of digits, letters, and special symbols, and must be at least 8 characters in length.' The form fields are: Email, Password, Confirm Password (must match the 1st password), and a checkbox for 'I have read and agreed to our Terms & Privacy Policy'. A 'Send' button is next to the checkbox.

B. Business user

* Select the data center based on your region and confirm.

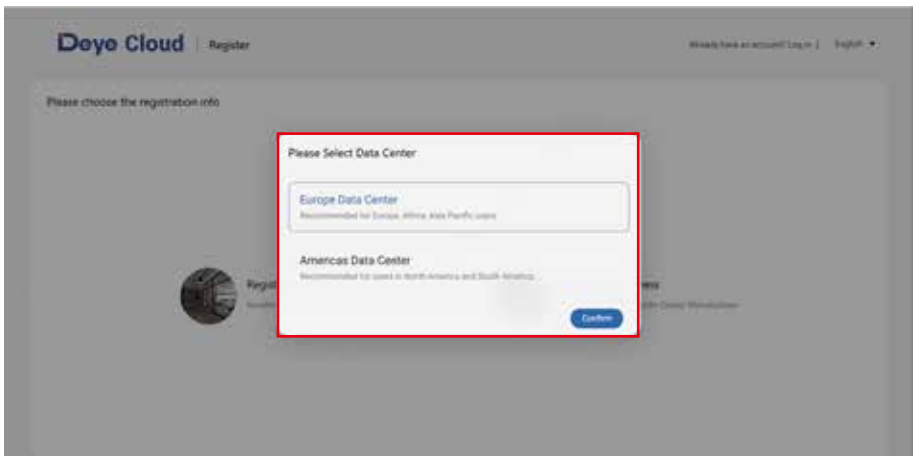

The screenshot shows the 'Deyo Cloud Register' page for a business user. A red box highlights the 'Please Select Data Center' dialog. The dialog has two options: 'Europe Data Center' (Recommended for Europe, Africa, Asia Pacific, Latin America) and 'Americas Data Center' (Recommended for USA, Canada, North America and South America). A 'Confirm' button is at the bottom right of the dialog.

* Enter the e-mail address and verification code received, check "T&Cs Privacy Policy", and click "Next".

The screenshot shows the registration page for Deye Cloud. At the top, there is a navigation bar with the Deye Cloud logo, the word "Register", and a link for "Already have an account? Log in | English". Below the navigation bar is a progress indicator with four steps: "Enter E-mail" (active), "Enter Account Info", "Enter Business Info", and "Registered". The main content area is a form for the "Enter E-mail" step, which includes an "Email" input field, a "Verification Code" input field with a "Send" button, a checkbox for "I have read and agreed to the Privacy Policy", and a "Next" button. A red box highlights the entire form area.

* Enter your name and password. Click "Next".

The screenshot shows the registration page for Deye Cloud, now on the "Enter Account Info" step. The progress indicator shows "Enter E-mail" as completed and "Enter Account Info" as the current step. The main content area is a form for the "Enter Account Info" step, which includes "Name", "Username", "Password" (with a strength indicator), and "Please confirm" (with a strength indicator) input fields. Below the input fields is a note: "The password must contain at least two types of digits, letters, and special symbols, and must be at least 6 characters in length." A "Next" button is at the bottom. A red box highlights the entire form area.

* Select your business type and area, set your business name, choose your identity, and click "Next".

The screenshot shows the 'Deyo Cloud | Register' page. At the top right, there are links for 'Already have an account? Log in |' and 'English |'. A progress bar at the top indicates four steps: 'Enter E-mail', 'Enter Account Info', 'Enter Business Info', and 'Registered'. The 'Enter Business Info' step is currently active. The form contains the following fields:

- Business Type:** Radio buttons for 'Company' (selected) and 'Individual'.
- Business Area:** A dropdown menu with 'China' selected.
- Business Name:** A text input field with 'English' in a dropdown and 'Business Name' in the input field.
- Title:** Radio buttons for 'Manufacturer/Content Provider', 'Seller', and 'Distributor'.
- Next:** A blue button at the bottom of the form.

* Your account is created successfully.

The screenshot shows the 'Deyo Cloud | Register' page after successful registration. The progress bar now shows four steps: 'Enter E-mail', 'Enter Account Info', 'Enter Business Info', and 'Registered'. The 'Registered' step is marked with a checkmark. The main content area displays:

- Created!** in bold text.
- Finished and Log In** in a blue button below it.

* Return to the log in page and log in.

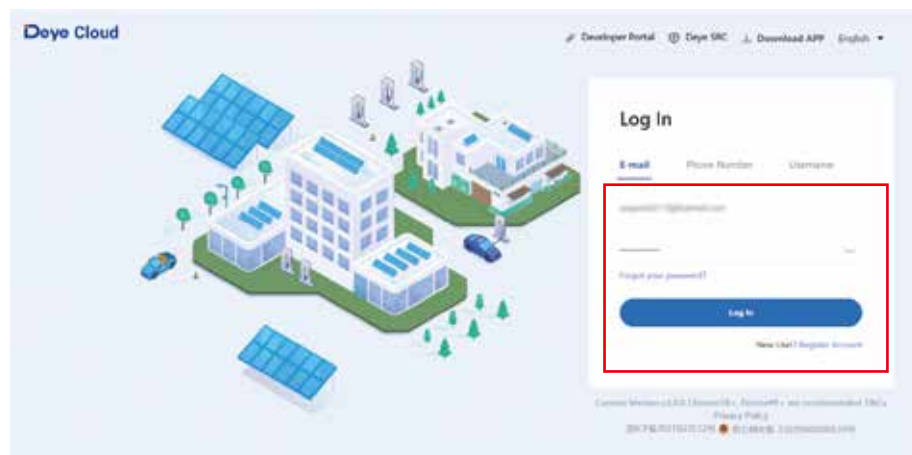

* Users can switch perspective on the top right. Note that this function is available to business account and residential user must register a business to enable this function.

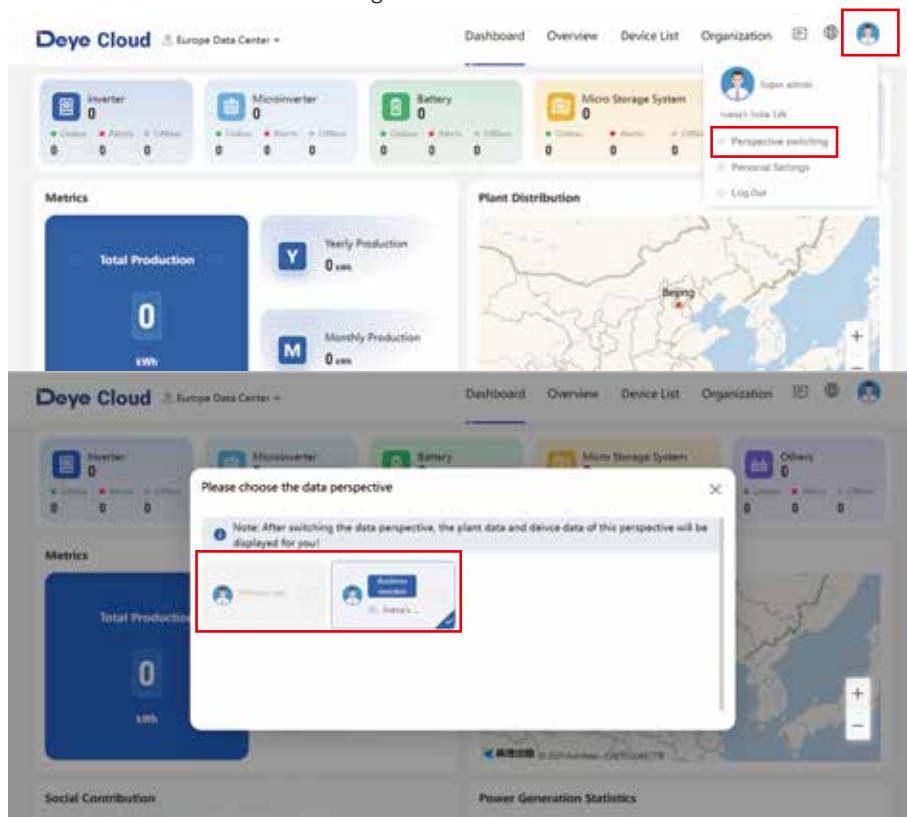

Step 2. Create the plant and add the logger

* After jumping to a new page, click "Create a Plant".

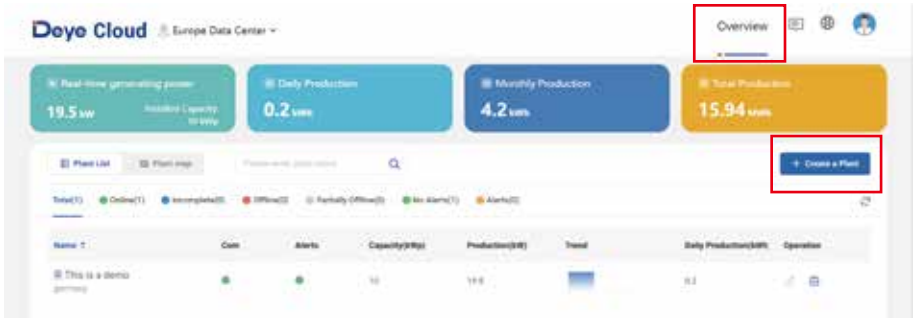

The screenshot shows the Deye Cloud dashboard with the following elements:

- Overview** tab selected in the top right.
- Production statistics: Real-time generating power (19.5 kW), Daily Production (0.2 MWh), Monthly Production (4.2 MWh), and Total Production (15.94 MWh).
- A **+ Create a Plant** button highlighted with a red box in the top right.
- A table with columns: Name, Gain, Alerts, Capacity(MWh), Production(MWh), Trend, Daily Production(MWh), and Operation.

* Fill out the basic information of the plant like plant name, location, grid type, and capacity. Click "Save" at the right top of this page to finish the plant creation.

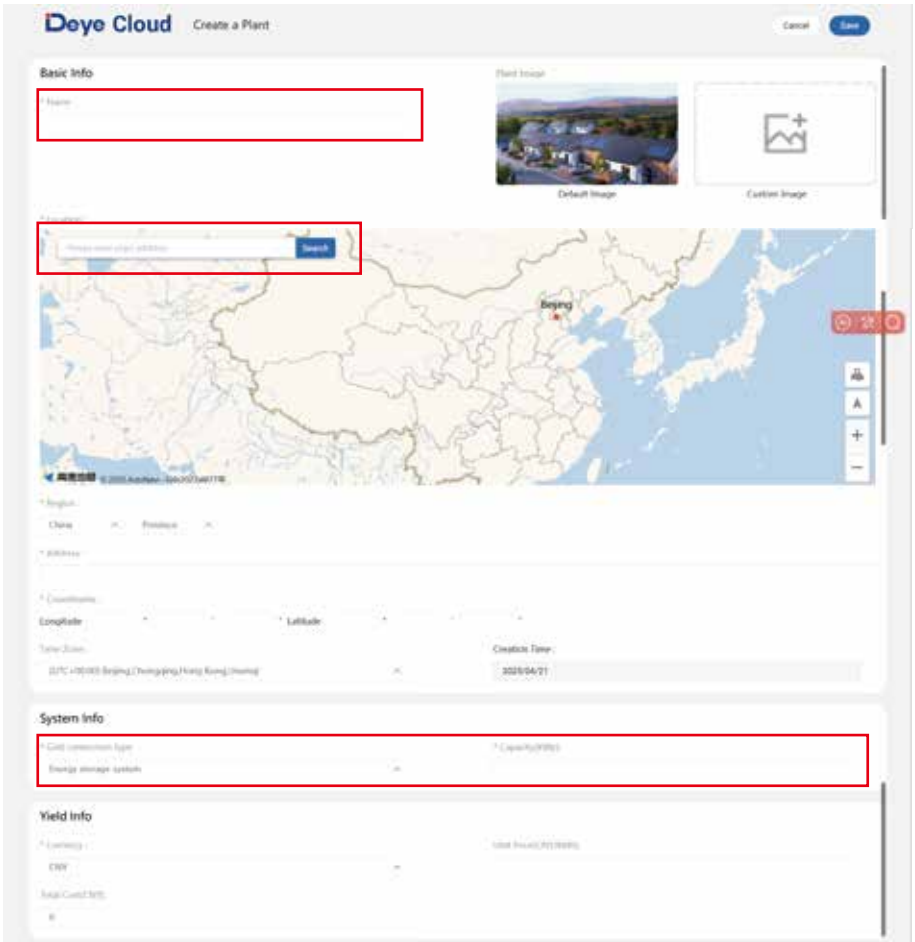

The screenshot shows the 'Create a Plant' form with the following sections:

- Basic Info**: Includes a text field for the plant name (highlighted with a red box) and a 'Plant Image' section with a 'Default Image' and a 'Custom Image' option.
- Location**: Includes a search bar for the plant address (highlighted with a red box) and a map showing the location in Beijing.
- System Info**: Includes a 'Grid connection type' dropdown (highlighted with a red box) and a 'Energy storage system' dropdown.
- Yield Info**: Includes a 'Capacity' dropdown and a 'Grid Type' dropdown.

* It will automatically open a new window. Select "Devices" and click "Add Data Logger".



* Click "+SN" to enter the SN of the logger (find it on the name plate of the microinverter). Click "Add" and click "Save" at the top right of this page. The device status will be gray now.

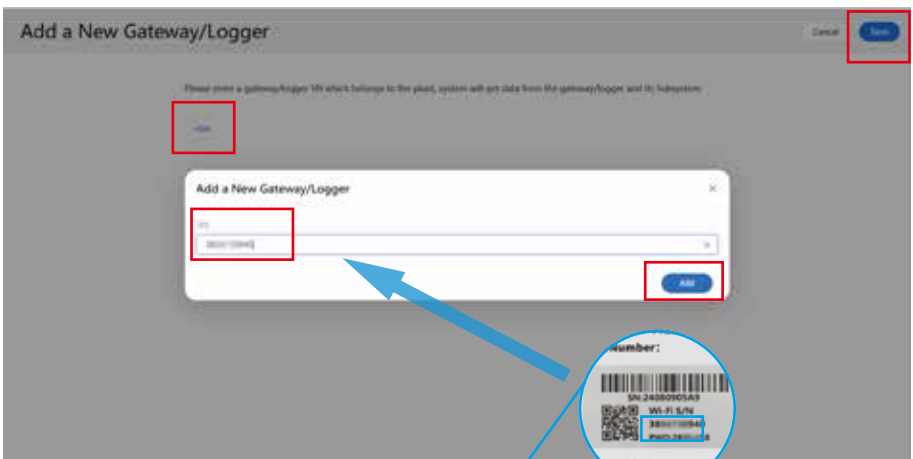

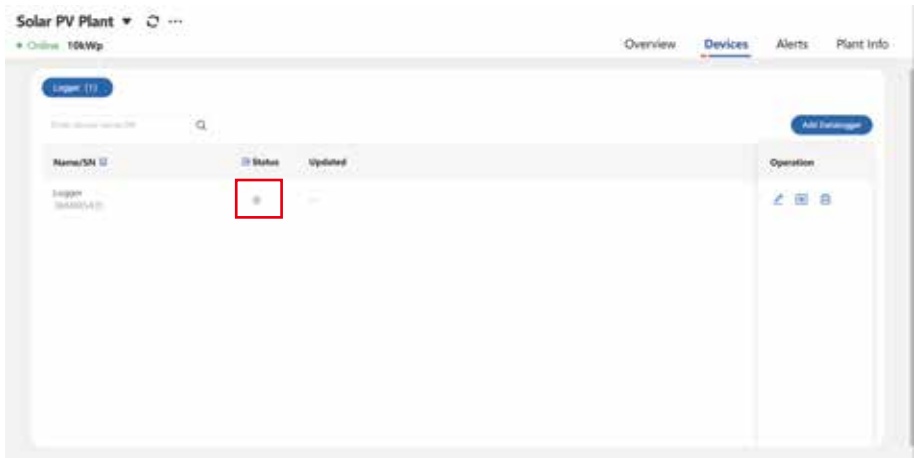

5.1.2 Wi-Fi Configuration

Step 1. Enable the wireless network on your PC

Step 2. Connect PC to the microinverter's AP network

- ✓ Find the AP network and password on the name plate of the microinverter. For example, in the picture below, the network is AP_3843994077 and its default password (PWD) is "dfe4e2a9".
- ✓ If there's no name plate that includes PWD on the microinverter, the default password of the AP network is 12345678.
- ✓ The default password can be changed (see Step 7). If you forget the modified password, please contact service@deye.com.cn for help.

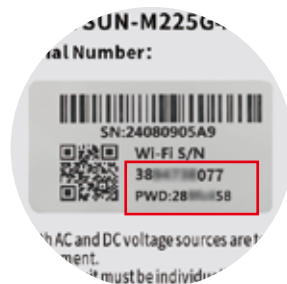

Step 3. Log into the platform and configure the network

* Open the browser and enter **10.10.100.254**. Enter the default username and password and they both are "admin". (Recommended browser: IE 8+, Chrome 15+, and Firefox 10+).

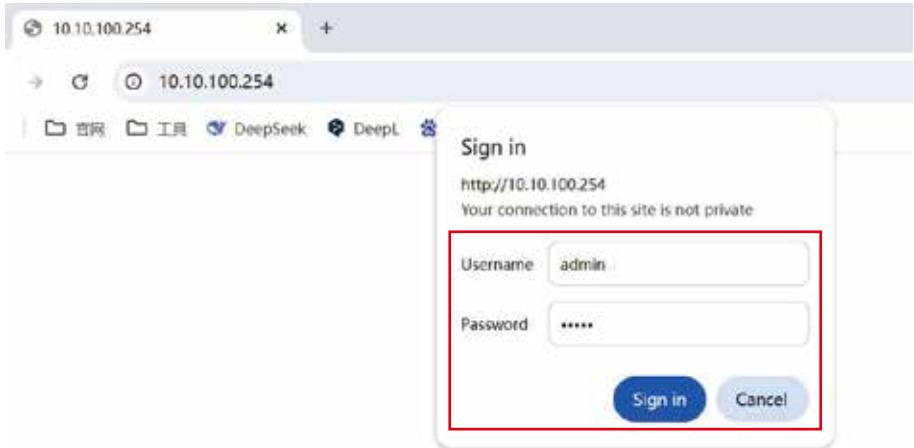

* The browser will jump to "Status" page and basic information is listed here.



* Select from three optional methods for enhancing the security and click "Next".

✓ **Hide AP:** Enable this option to make the wireless network invisible to others. Only devices with the correct network name (SSID) can connect.

✓ **Change the encryption mode for AP:** Select a different encryption method like WPA2-PSK to enhance the security.

✓ **Change the user name and password for Web server:** Modify the login credentials (username and password) for accessing the web management interface to improve security.

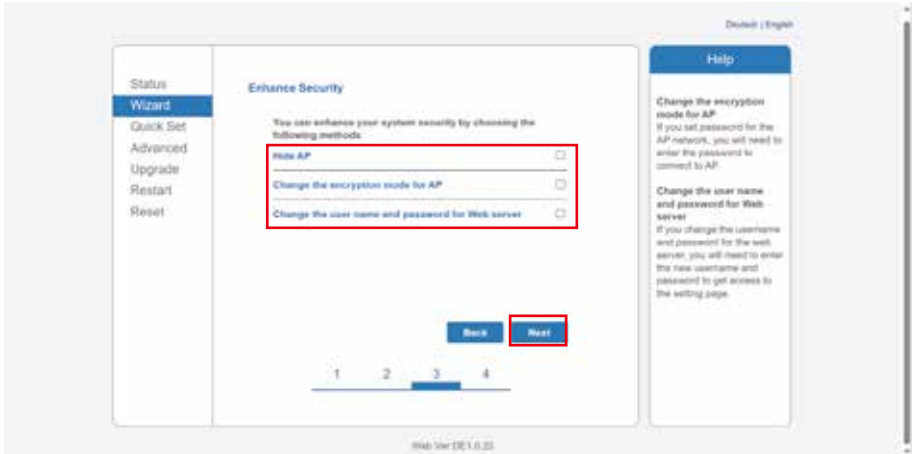

* With a successful setup, the following page will pop up and click "OK" to reboot the microinverter.

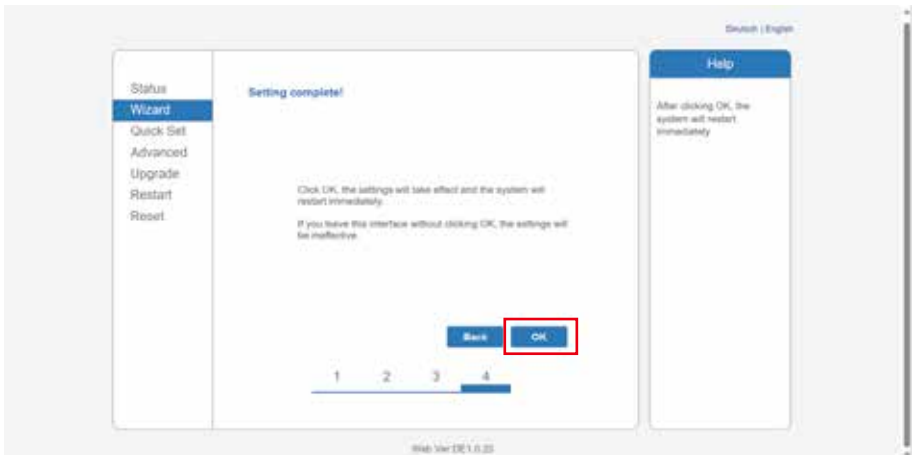

* Connect to the AP network again and log in to 10.10.100.254 in browser. Check the "Status" page and the remote server A or B should be "connected" after a successful Wi-Fi configuration.



* After successful configuration, the status of the microinverter will be online (in green). Return to the Deye cloud home page and users can check the system status. Please note that data will be updated within 10 to 15 minutes after the initial successful configuration.

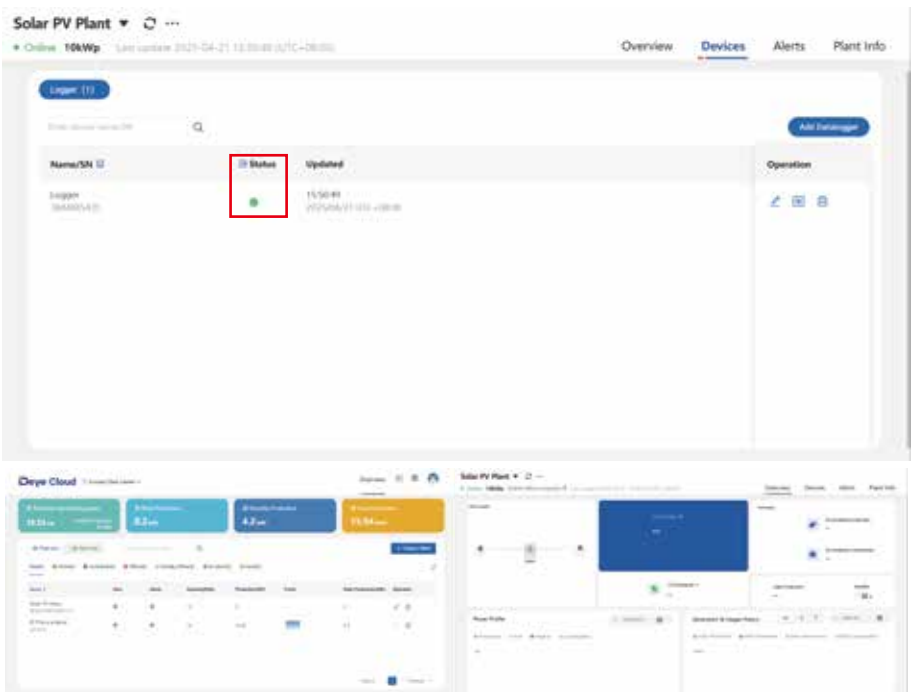

5.2 Monitoring via Mobile App

Step 1. Download the app

Scan the QR code below to download the app or search "Deye Cloud" in app store (iOS) or Google Play Store (Android). Install the app on your mobile phone.



Deye Cloud

Green Industry, Bright Future



Scan to Download the App



Step 2. Register an account

* Read the information on the pop up window and click "I agree" and then click "Register account".

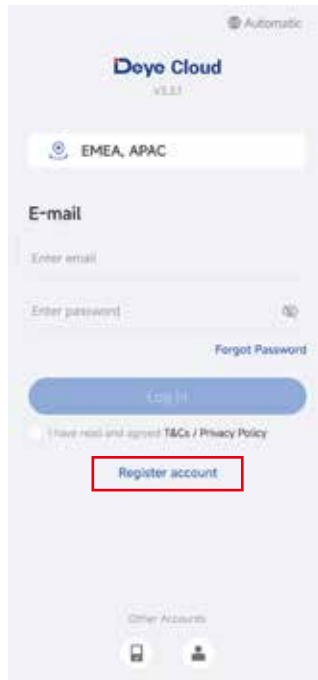
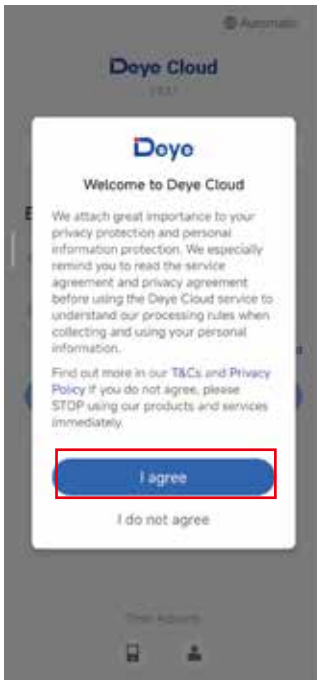

* Select data center, enter your email address, and check "Terms of Service" and "Privacy Policy". Enter the verification code, set the password and click "Confirm" to create a new account.

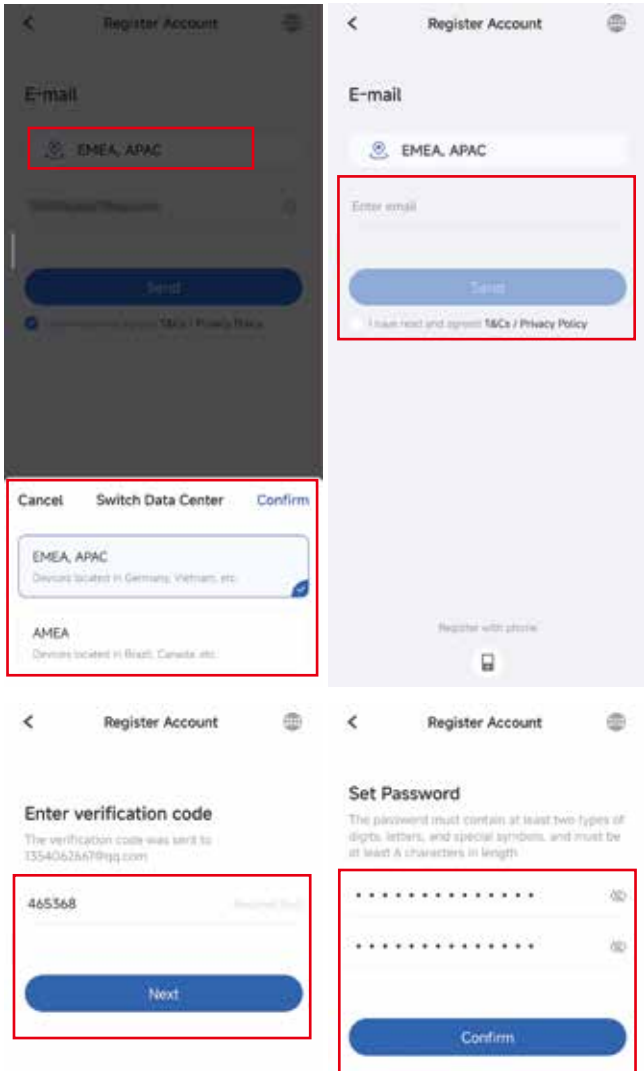

Step 3. Create the plant

Close the pop window and create a new plant at the top right of this page. Enter the information like plant name, plant address, system type, system capacity and click "Confirm".

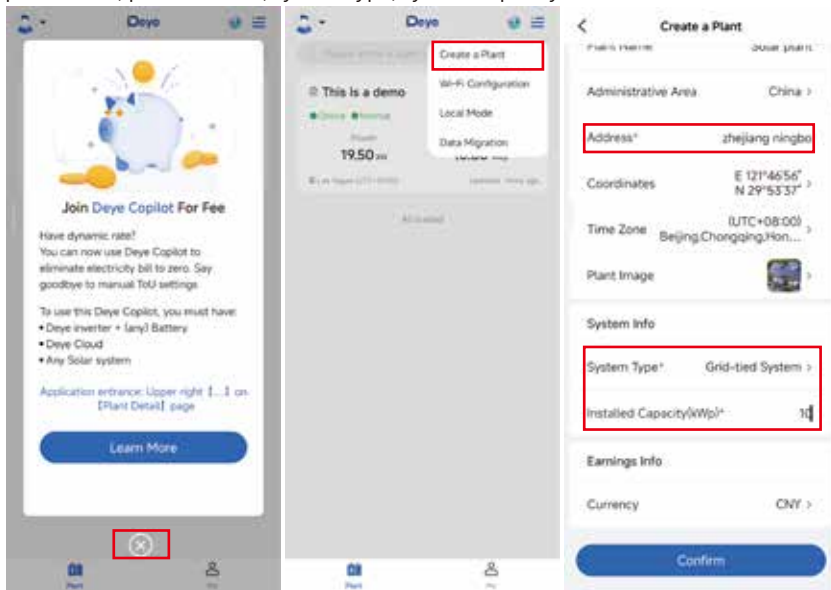

Step 4. Configure the network

* Select "Later" on the pop up window, return to the home page, and turn on Bluetooth of the mobile phone. Click the "Wi-Fi Configuration" icon in the top right corner, select "Wi-Fi Configuration", and the app will scan for nearby devices automatically.

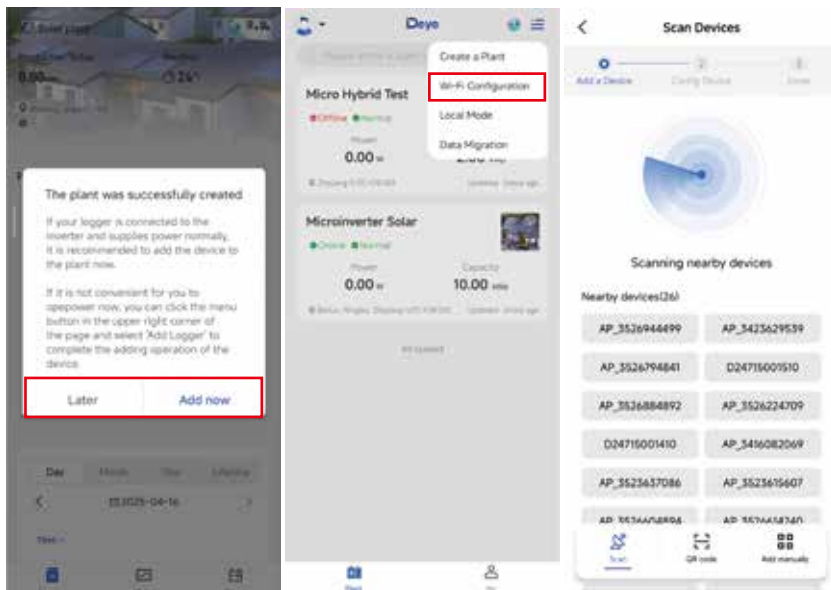

* Select the AP network of the inverter you want to connect. Choose a 2.4G Wi-Fi network, enter the password, and click "Next".

✓ Find the AP network name on the name plate of the microinverter.

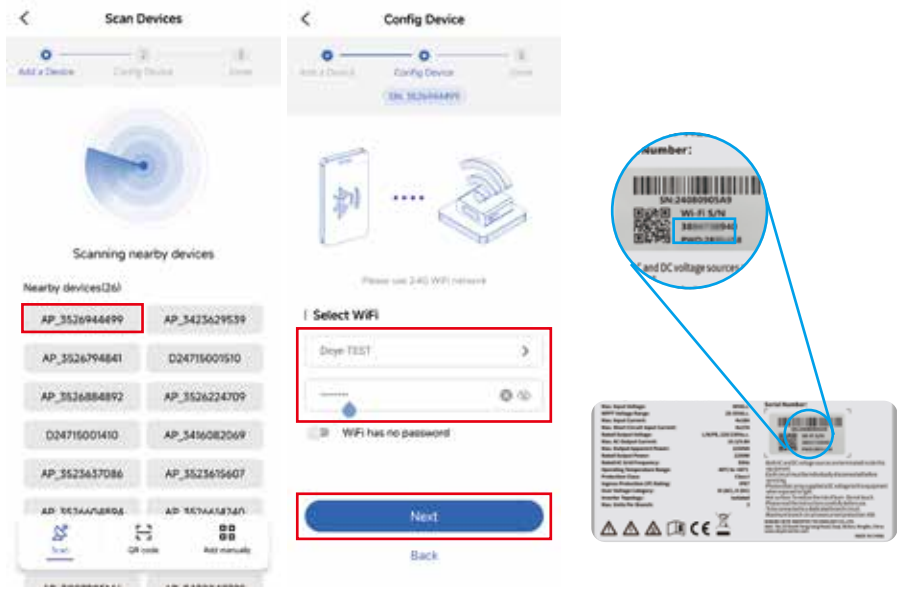

* The Wi-Fi setup will begin. Please stay on this page and keep your phone close to the device. Once the setup is complete, you can name the device. Click "Complete" to finish.

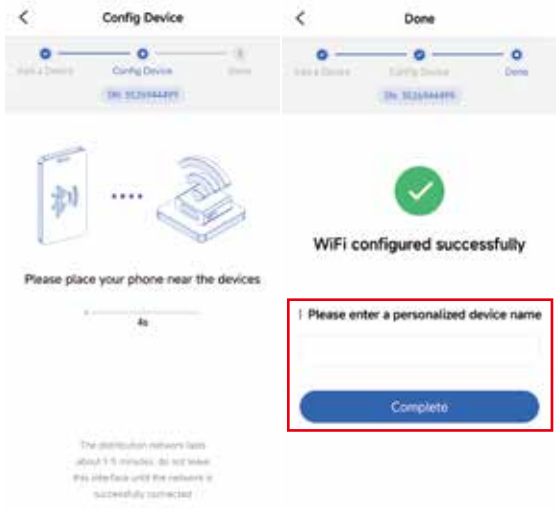

Step 5. Monitoring and management

Wait for some time until it shows the device is online and the data is collected. Check the system status and data on overview and data page.

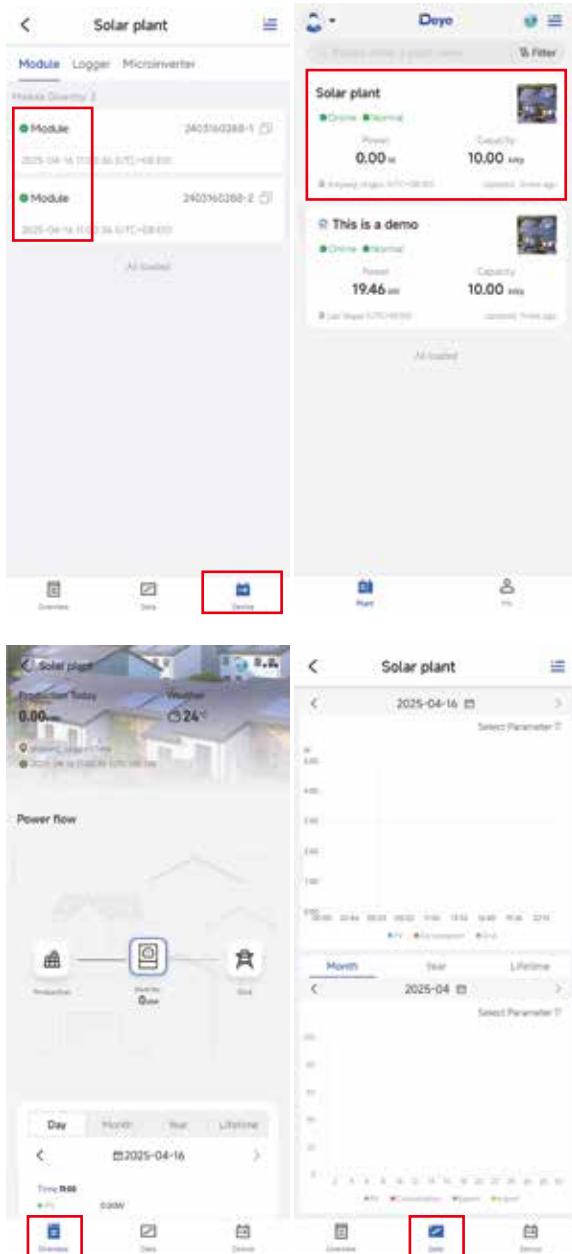

6. Appendix

6.1 Technical Data

WARNING: Be sure to verify the voltage and current specifications of your PV module match with those of the microinverter. Please refer to the datasheet or user manual.

WARNING: The DC operating voltage range of the PV module must be matched with the allowable input voltage range of the microinverter.

WARNING: The maximum open circuit voltage of the PV module must not exceed the specified maximum input voltage of the microinverter.

Model	SUN-E60G4-EU-Q0	SUN-E80G4-EU-Q0	SUN-E100G4-EU-Q0	SUN-E110G4-EU-Q0
PV String Input Data				
Max. PV Input Power (W)	210-420(2 Pieces)	210-560(2 Pieces)	210-700(2 Pieces)	210-770(2 Pieces)
Max. PV Input Voltage (V)	60			
Start-up Voltage (V)	20			
PV Input voltage range(V)	20-60			
MPPT Voltage Range (V)	25-55			
Full Load MPPT Voltage Range(V)	30-55	33-55	37.5-55	38-55
Rated PV Input Voltage (V)	42.5			
Max. Input Short Circuit Current (A)	27x2			
Max. Operating PV Input Current (A)	18x2			
No. of MPP Trackers/ No. of Strings MPP Tracker	2/1			
Max. Inverter Backfeed Current To the Array	0			
AC Output Side				
Rated AC Output Active Power (W)	600	800	1000	1100
Max. AC Output Apparent Power (VA)	600	800	1000	1100
Rated AC Output Current (A)	2.8/2.7	3.7/3.5	4.6/4.4	5/4.8
Max. AC Output Current (A)	2.8/2.7	3.7/3.5	4.6/4.4	5/4.8
Max. Output Fault Current(A)	8			
Max. Output Overcurrent Protection (A)	21			
Rated Output Voltage/Range (V)	220/230 0.85Un-1.1Un			
Grid Connection Form	L/N/PE			
Rated Output Grid Frequency/Range(Hz)	50/45-55, 60/55-65			
Power Factor Adjustment Range	0.9leading-0.9lagging/0.95leading-0.95lagging(VDE4105)			
Total Current Harmonic Distortion THDi	<3%			
DC Injection Current	<0.5%In			
Efficiency				
Max. Efficiency	96.5%			
Euro Efficiency	96.0%			
MPPT Efficiency	>99%			
Equipment Protection				
DC Reverse Polarity Protection	Yes			
AC Output Overcurrent Protection	Yes			
AC Output Overvoltage Protection	Yes			
AC Output Short Circuit Protection	Yes			
Thermal Protection	Yes			
Insulation Impedance Detection	Yes			
Anti-islanding protection	Yes			
Surge Protection Level	TYPE II(AC)			
Interface				
Communication Interface	Wi-Fi			
General Data				
Operating Temperature Range (°C)	-40 to +65°C, >45°C Derating			
Permissible Ambient Humidity	0-100%			
Permissible Altitude (m)	2000m			
Noise (dB)	≤25			

Model	SUN-E60G4-EU-Q0	SUN-E80G4-EU-Q0	SUN-E100G4-EU-Q0	SUN-E110G4-EU-Q0
Ingress Protection(IP) Rating	IP 67			
Inverter Topology	Isolated			
Over Voltage Category	OVC II(DC), OVC III(AC)			
Cabinet Size (WxHxD mm)	200.5×177.8×35.5 (Excluding Connectors and Brackets)			
Weight (kg)	2.4			
Warranty	Standard 10 years, extended warranty			
Type of Cooling	Natural Cooling			
Grid Regulation	IEC 61727, IEC 62116, CEI 0-21, EN 50549, NRS 097, RD 140, UNE 217002, G98, VDE-AR-N 4105			
Safety EMC/Standard	IEC/EN 61000-6-1/2/3/4, IEC/EN 62109-1, IEC/EN 62109-2			

Maintenance: Deye microinverters do not require any specific regular maintenance.

Troubleshooting: If you have any problems when using Deye products, please contact our after services team for help by email at service@deye.com.cn. For more details, please refer to product warranty policies.

6.2 EU Declaration of Conformity



Within the scope of the EU directives:

- Radio Equipment Directive 2014/53/EU (RED)
- Restriction of the use of certain hazardous substances 2011/65/EU (RoHS)

NINGBO DEYE INVERTER TECHNOLOGY CO., LTD. confirms herewith that the products described in this document are in compliance with the fundamental requirements and other relevant provisions of the above mentioned directives. The entire EU Declaration of Conformity and certificate can be found at <https://www.deyeinverter.com/download/#microinverter-4>.

EU Declaration of Conformity

Product: **Utility-Interactive Inverter**

Models: SUN-E60G4-EU-Q0; SUN-E80G4-EU-Q0; SUN-E100G4-EU-Q0;

Name and address of the manufacturer: Ningbo Deye Inverter Technology Co., Ltd.

No. 26 South Yongjiang Road, Daqi, Beilun, NingBo, China

This declaration of conformity is issued under the sole responsibility of the manufacturer. Also this product is under manufacturer's warranty.

This declaration of conformity is not valid any longer: if the product is modified, supplemented or changed in any other way, as well as in case the product is used or installed improperly.

The object of the declaration described above is in conformity with the relevant Union harmonization legislation: The restriction of the use of certain hazardous substances (RoHS) Directive 2011/65/EU and the Radio Equipment Directive (RED) 2014/53/EU.

References to the relevant harmonized standards used or references to the other technical specifications in relation to which conformity is declared:

EN 62109-1:2010	●
EN 62109-2:2011	●
EN IEC 61000-6-1:2019	●
EN IEC 61000-6-2:2019	●
EN IEC 61000-6-3:2021	●
EN IEC 61000-6-4:2019	●
EN IEC 61000-3-2:2019+A1:2021	●
EN 61000-3-3:2013/A2:2021/AC:2022-01	●
EN IEC 61000-3-11:2019	●
EN 61000-3-12:2011	●
EN 55011:2016/A2:2021	●
EN 62920:2017/A1:2021	●
EN 300328 V 2.2.2:2019	●
EN 301489-1 V 2.2.3:2019	●
EN 301489-17 V 3.2.4:2020	●
EN IEC 62311:2020	●
CISPR 11:2015+A1+A2	●

Nom et Titre / Name and Title:

Bard Dai

Senior Standard and Certification Engineer

Au nom de / On behalf of:

Date / Date (yyyy-mm-dd):

A / Place:
EU DoC - v2

宁波德业变频技术有限公司

Ningbo Deye Inverter Technology Co., Ltd.

2025-06-02

Ningbo, China

Ningbo Deye Inverter Technology Co., Ltd.
No. 26 South Yongjiang Road, Daqi, Beilun, NingBo, China

