



Hybrid Inverter

SUN-100K-SG02HP3-EU-GM8

SUN-100K-SG02HP3-EU-GM10

SUN-125K-SG02HP3-EU-GM10

User Manual

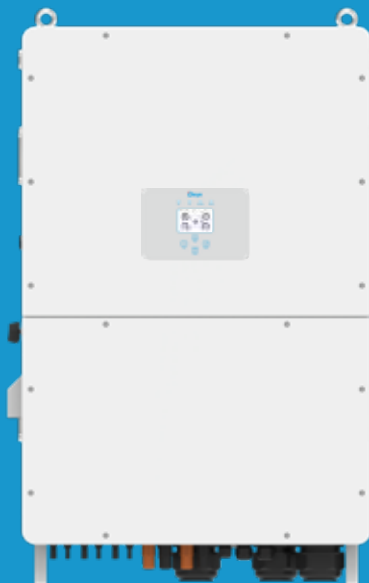

Contents

1. Safety Introductions	01-02
2. Product instructions	02-06
2.1 Product Overview	
2.2 Product Size	
2.3 Product Features	
2.4 Basic System Architecture	
2.5 Product handling requirements	
3. Installation	06-30
3.1 Parts list	
3.2 Mounting instructions	
3.3 Function port definition	
3.4 Battery connection	
3.5 Grid connection and backup load connection	
3.6 PV Connection	
3.7 Meter or CT installation	
3.8 Earth Connection(mandatory)	
3.9 Data logger connection	
3.10 Wiring diagram with neutral line grounded	
3.11 Wiring diagram with neutral line ungrounded	
3.12 Typical application diagram of on-grid system	
3.13 Typical application diagram of diesel generator	
3.14 Three phase parallel connection diagram	
4. OPERATION	31
4.1 Power ON/OFF	
4.2 Operation and Display Panel	
5. LCD Display Icons	32-52
5.1 Main Screen	
5.2 Detail page	
5.3 Curve Page-Solar & Load & Grid	
5.4 Setting Menu	
5.5 Basic setup Menu	
5.6 Grid Setup Menu	
5.7 Battery Setup Menu	
5.8 Quick Control Menu	
5.9 Info and Fault Code Menu	
5.10 Gen and Aux Load Menu	
5.11 System Mode Menu	
5.12 Network Menu	
5.13 Advanced Menu	
6. Mode	52-53
7. Warranty	53-54
8. Troubleshooting	54-59
9. Datasheet	60-61
10. Appendix I	61-63
11. Appendix II	64
12. Appendix III	65
13. EU Declaration of Conformity	65-67

About This Manual

This manual provides information and guidelines for the installation, operation, and maintenance of the SUN-100K-SG02HP3-EU-GM8/SUN-(100-125)K-SG02HP3-EU-GM10 inverter. Please note that it does not contain comprehensive information about the photovoltaic (PV) system.







How to Use This Manual

Before undertaking any operation involving the inverter, it is crucial to thoroughly read this manual and any associated documents. Ensure that these documents are stored safely and are readily accessible at all times.

Please be aware that the contents of this manual may undergo periodic updates or revisions as a result of ongoing product development. Consequently, the information contained herein is subject to change without prior notice. The latest manual can be acquired via service@deye.com.cn

1. Safety Introductions

Labels description

Label	Description
	Caution, risk of electric shock symbol indicates important safety instructions, which if not correctly followed, could result in electric shock.
	The DC input terminals of the inverter must not be grounded.
	Surface high temperature, Please do not touch the inverter case.
	The AC and DC circuits must be disconnected separately, and the maintenance personnel must wait for 5 minutes before they are completely powered off before they can start working.
	CE mark of conformity
	Please read the instructions carefully before use.
	Symbol for the marking of electrical and electronics devices according to Directive 2002/96/EC. Indicates that the device, accessories and the packaging must not be disposed as unsorted municipal waste and must be collected separately at the end of the usage. Please follow Local Ordinances or Regulations for disposal or contact an authorized representative of the manufacturer for information concerning the decommissioning of equipment.

- This chapter contains important safety and operating instructions. Read and keep this manual for future reference.
- Before using the inverter, please read the instructions and warning signs of the battery and corresponding sections in the instruction manual.
- Do not disassemble the inverter. If you need maintenance or repair, take it to a professional service center.
- Improper reassembly may result in electric shock or fire.
- To reduce risk of electric shock, disconnect all wires before attempting any maintenance or cleaning. Turning off the unit will not reduce this risk.
- Caution: Only qualified personnel can install this device with battery.
- Never charge a frozen battery.
- For optimum operation of this inverter, please follow required specification to select appropriate cable size. It is very important to correctly operate this inverter.
- Be very cautious when working with metal tools on or around batteries. Dropping a tool may cause a spark or short circuit in batteries or other electrical parts, even cause an explosion.
- Please strictly follow installation procedure when you want to disconnect AC or DC terminals. Please refer to "Installation" section of this manual for the details.
- Grounding instructions - this inverter should be connected to a permanent grounded wiring system. Be sure to comply with local requirements and regulation to install this inverter.
- Never cause AC output and DC input short circuited. Do not connect to the mains when DC input short circuits.

Hoisting Notes

If the inverter is installed in a high position, you can hung it up.

- Only trained and approved personnel are allowed to perform hoisting operations.
- Install temporary warning signs or fences to far away the hoisting area.
- Make sure that the foundation where hoisting is performed on meets the load bearing requirements.
- Before hoisting objects, make sure that hoisting tools are firmly secured onto a fixed object or wall that meets the load-bearing requirements.
- When hoisting, do not stay under the crane or the hoisted objects.
- Do not drag steel ropes and hoisting tools or bump the hoisted things against hard things when hoisting.

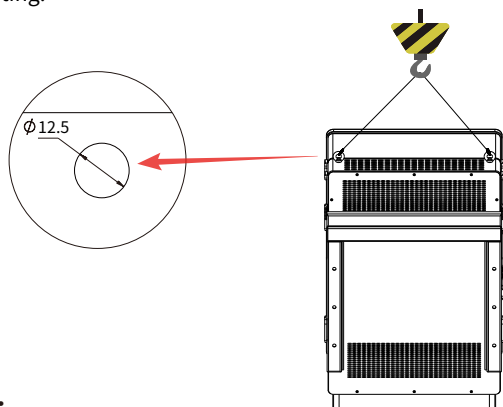

2. Product Introductions

This is a multifunctional inverter, combining functions of inverter, solar charger and battery charger to offer uninterruptible power support with portable size. Its comprehensive LCD display offers user configurable and easy accessible button operation such as battery charging, AC/solar charging, and acceptable input voltage based on different applications.

2.1 Product Overview

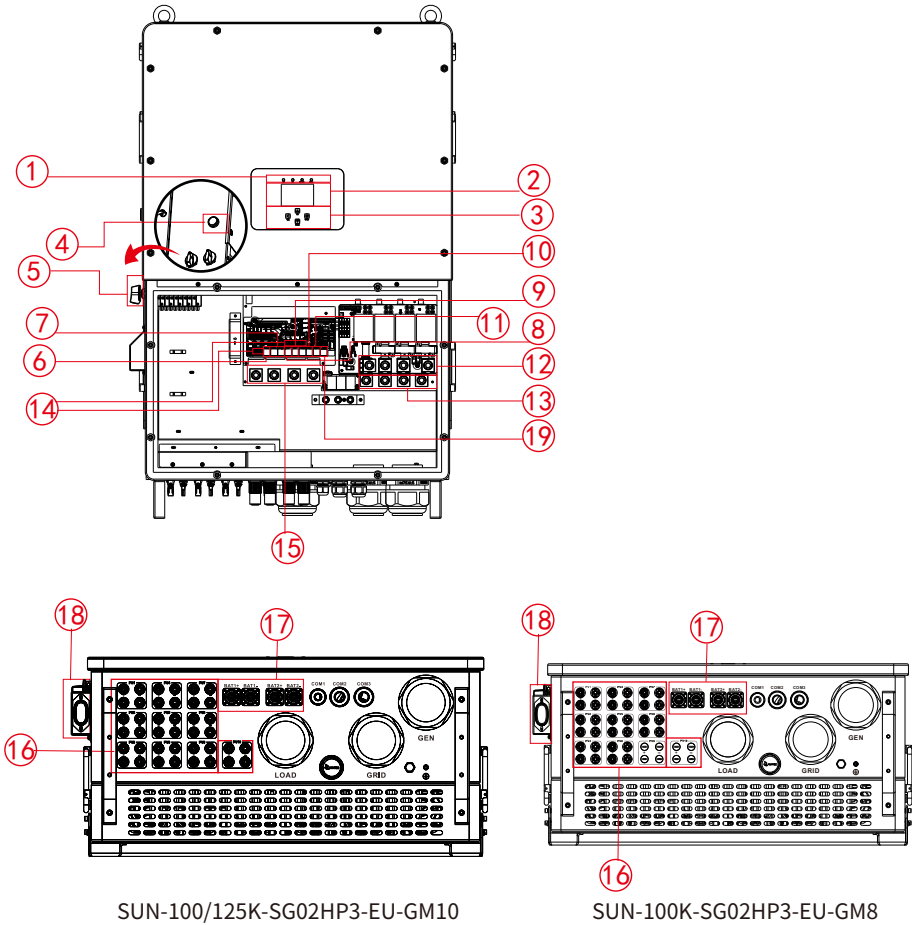

SUN-100/125K-SG02HP3-EU-GM10

SUN-100K-SG02HP3-EU-GM8

- | | | | |
|------------------------|---------------------|----------------------|--------------|
| 1: Inverter indicators | 7: Parallel port | 13: Grid | 19: LAN port |
| 2: LCD display | 8: CAN port | 14: Function port | |
| 3: Function buttons | 9: DRM port | 15: Load | |
| 4: Power on/off button | 10: BMS port | 16: PV input | |
| 5: DC switch | 11: RS485 port | 17: Battery input | |
| 6: Meter port | 12: Generator input | 18: Logger interface | |

2.2 Product Size

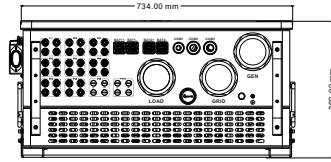
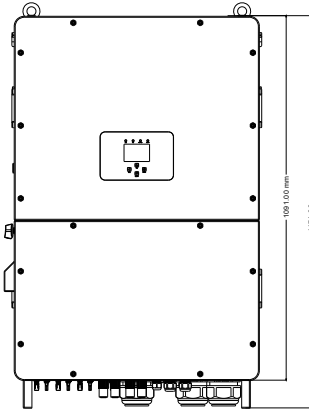

SUN-100K-SG02HP3-EU-GM8

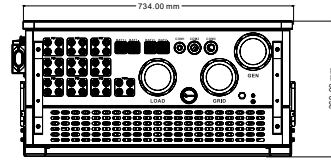

SUN-100/125K-SG02HP3-EU-GM10

Inverter Size

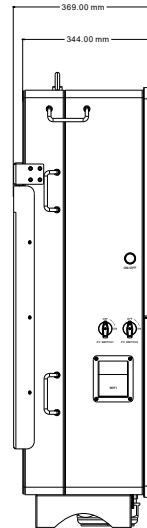
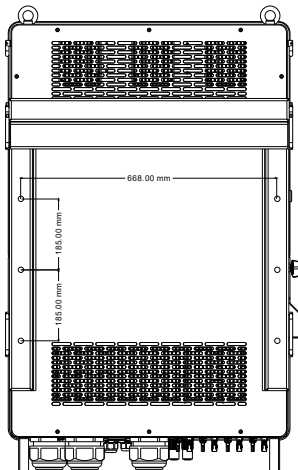

2.3 Product Features

- 230V/400V Three phase Pure sine wave inverter.
- Self-consumption and feed-in to the grid.
- Auto restart while AC is recovering.
- Programmable supply priority for battery or grid.
- Programmable multiple operation modes: On grid, off grid and UPS.
- Configurable battery charging current/voltage based on applications by LCD setting.
- Configurable AC/Solar/Generator Charger priority by LCD setting.
- Compatible with mains voltage or generator power.
- Overload/over temperature/short circuit protection.
- Smart battery charger design for optimized battery performance
- With limit function, prevent excess power overflow to the grid.
- Supporting WIFI monitoring and have 3 or 4 built-in MPP Trackers, 1 MPP Tracker can connect 2 PV strings.
- Smart three-stage charging strategy with customizable settings can optimize battery performance.
- Time of use function.
- Smart Load Function.

2.4 Basic System Architecture

The following illustration shows basic application of this inverter.

It also includes following devices to have a complete running system.

- Generator (Fro off-grid mode) or Utility Grid
- PV modules

Consult with your system integrator for other possible system architectures depending on your requirements.

This inverter is designed to power a range of appliances commonly found in homes and offices, including motor type appliances like refrigerators and air conditioning units. Before use, it's advisable to verify appliance compatibility with this inverter.

The generator interface should not be connected to both the generator and the smart load simultaneously. The generator only can be connected in stand-alone scenario. When the grid be connected, the generator should not be connected simultaneously.

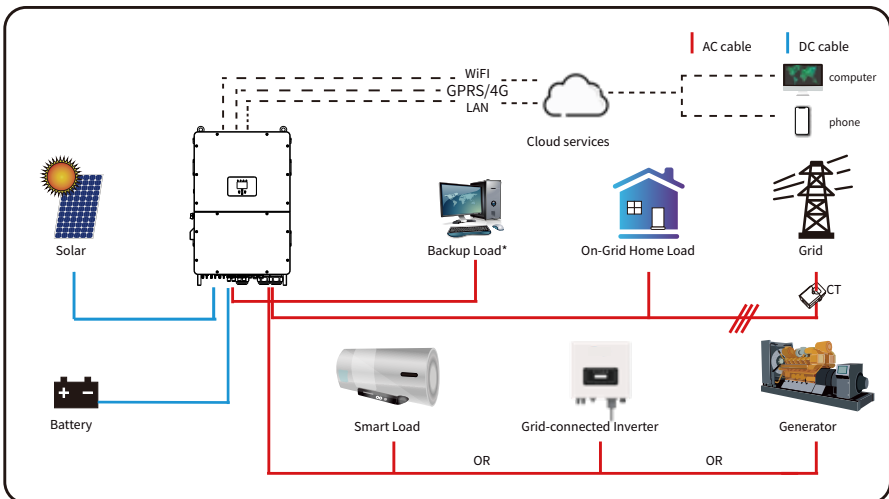

*Connected to the LOAD port

2.5 Product handling requirements

Lift the inverter out of the packaging box and transport it to the designated installation location.

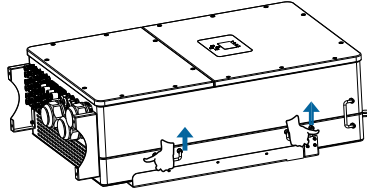

transport



CAUTION:

Improper handling may cause personal injury!

- Arrange an appropriate number of personnel to carry the inverter according to its weight, and installation personnel should wear protective equipment such as anti-impact shoes and gloves.
- Placing the inverter directly on a hard ground may cause damage to its metal enclosure. Protective materials such as sponge pad or foam cushion should be placed underneath the inverter.
- Move the inverter by one or two people or by using a proper transport tool.
- Move the inverter by holding the handles on it. Do not move the inverter by holding the terminals.

3. Installation

3.1 Parts List

Check the equipment before installation. Please make sure nothing is damaged in the package. You should have received the items in the following package:

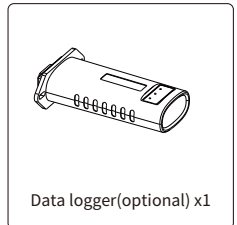
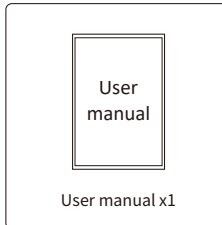
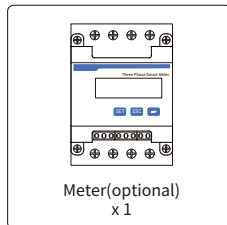
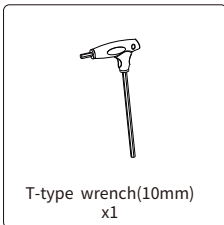
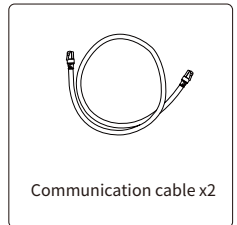
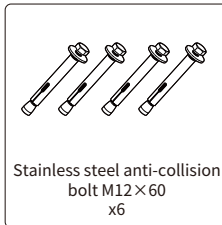
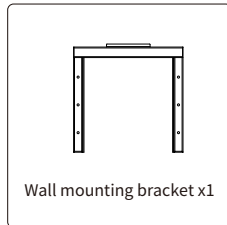
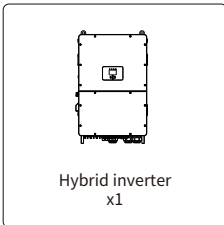

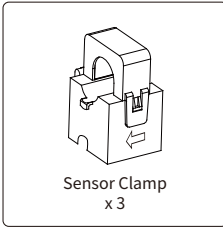

Sensor Clamp
x3

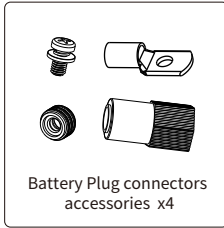

Battery Plug connectors
accessories x4

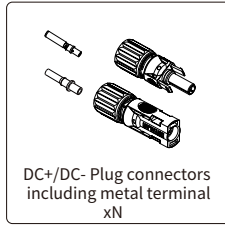

DC+/DC- Plug connectors
including metal terminal
xN

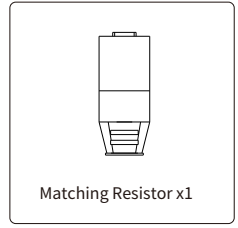

Matching Resistor x1

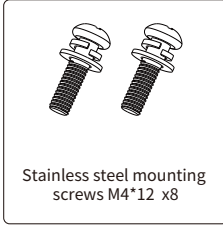

Stainless steel mounting
screws M4*12 x8

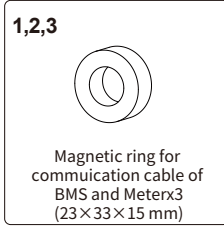

1,2,3

Magnetic ring for
communication cable of
BMS and Meterx3
(23×33×15 mm)

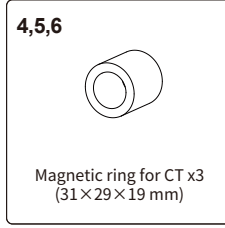

4,5,6

Magnetic ring for CT x3
(31×29×19 mm)

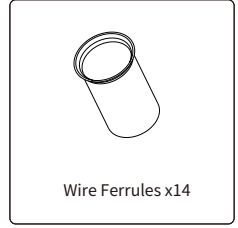

Wire Ferrules x14

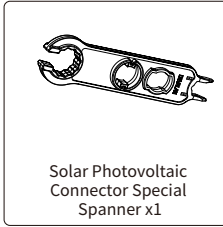

Solar Photovoltaic
Connector Special
Spanner x1

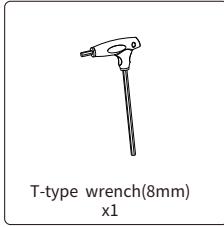

T-type wrench(8mm)
x1

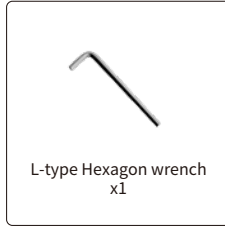

L-type Hexagon wrench
x1

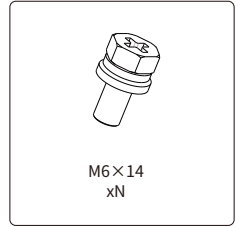

M6×14
xN

Packing box of magnetic ring

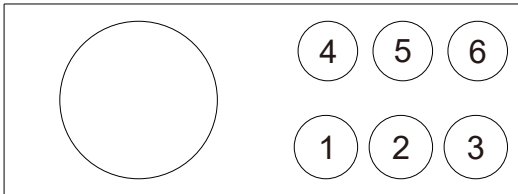

1,2,3 : 23×33×15 mm
4,5,6 : 31×29×19mm

3.2 Mounting instructions

Installation Precaution

This Hybrid inverter is designed for outdoor use(IP65), Please make sure the installation site meets below conditions:

- Not in direct sunlight, rain exposure, snow laying up during installation and operation.
- Not in areas where highly flammable materials are stored.
- Not in potential explosive areas.
- Not directly expose to the cold air to avoid condensation inside the inverter casing .
- Not near the television Antenna or antenna cable.
- Not higher than altitude of about 2000 meters above sea level.
- Not in environment of precipitation or humidity(>95%)

Excessive heat buildup, heavy rainfall or water pooling, can impact the performance and longevity of the inverter. Before connecting all wires, please take off the metal cover by removing screws as shown below:

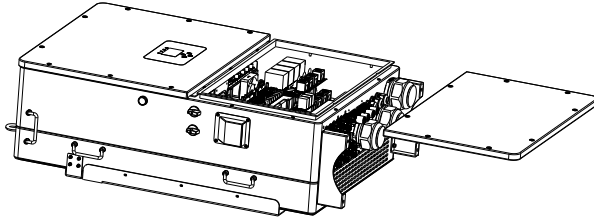

Installations Tools

Installation tools can refer to the following recommended ones. Also, use other auxiliary tools on site.



Protective goggles



Anti-dust mask

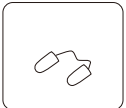

Earplugs



Work gloves



Work shoes

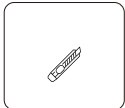

Utility Knife

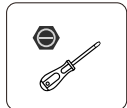

Slotted screwdriver

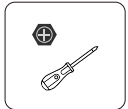

Cross screwdriver

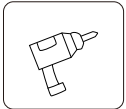

Percussion drill

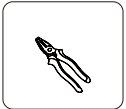

Pliers



Marker



Level



Rubber hammer



socket wrenches set

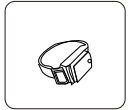

Anti-static wrist strap

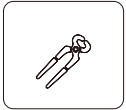

Wire cutter

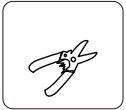

Wire stripper

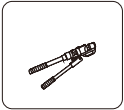

Hydraulic pliers

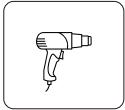

Heat gun

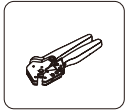

Crimping tool4-6mm²

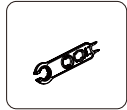

Solar connector wrench



Multimeter ≥ 1100 Vdc

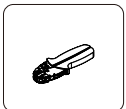

RJ45 crimping plier



Cleaner



Spanner

Considering the following points before selecting where to install:

- Please select a vertical wall with load-bearing capacity for installation, suitable for installation on concrete or other non-flammable surfaces, installation as follows.
- Install this inverter at eye level in order to allow the LCD display to be read at all times.
- The ambient temperature is recommended to be between -40~60°C to ensure optimal operation.
- Be sure to keep enough distance between other objects and the inverter surfaces as shown in the diagram to guarantee sufficient heat dissipation and have enough space for removing wires.

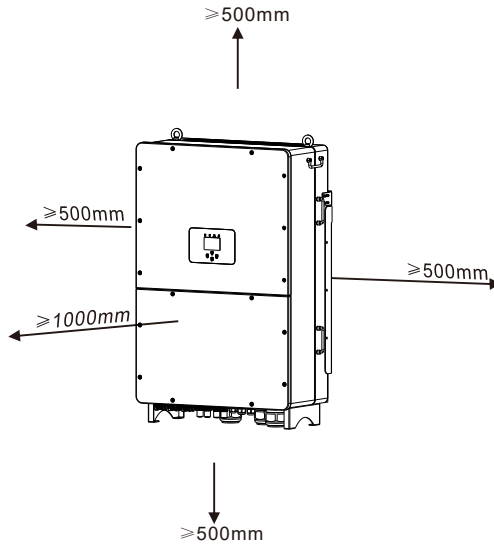

For a proper ventilation of the inverter and avoid overheating, allow a clearance of approximately 50 cm around the inverter and at least 100 cm to the front as it can be seen at the picture below.

Mounting the inverter

Remember that this inverter is heavy! Please be careful when lifting out from the package. Choose the recommend drill head(as shown in below pic) to drill 4 holes on the wall, 62-70mm deep.

1. Use a proper hammer to fit the expansion bolt into the holes.
2. Screw out the nuts of the expansion bolts, align the holes of the mounting bracket with the 4 expansion bolts, and then push in the mounting bracket, tighten the nuts of expansion bolts.
3. Mount the inverter on the mounting bracket and use screws to fix the inverter with mounting bracket.

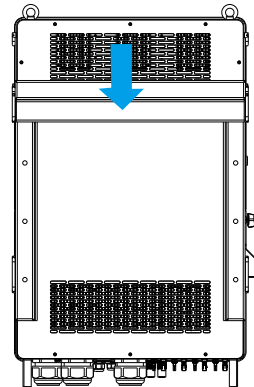
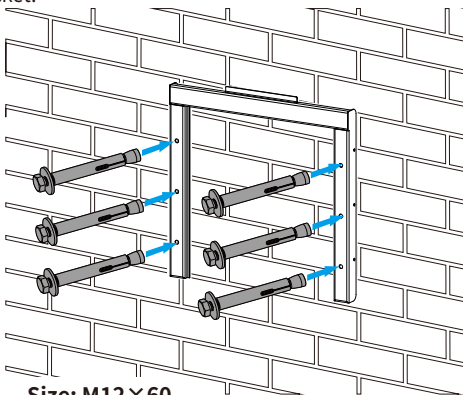

Inverter Mounting bracket installation

3.3 Function port definition

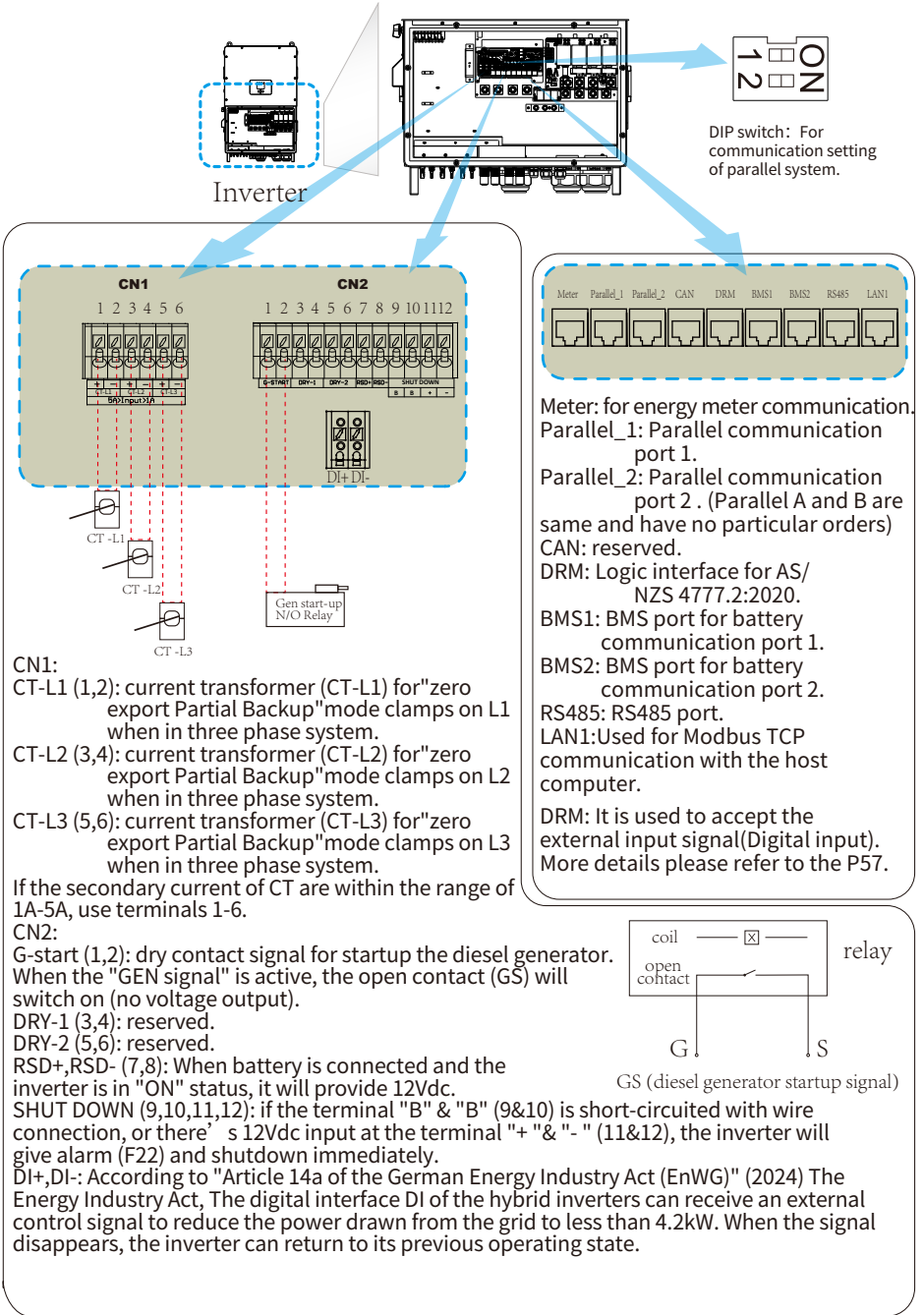

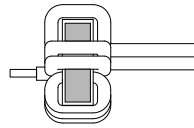
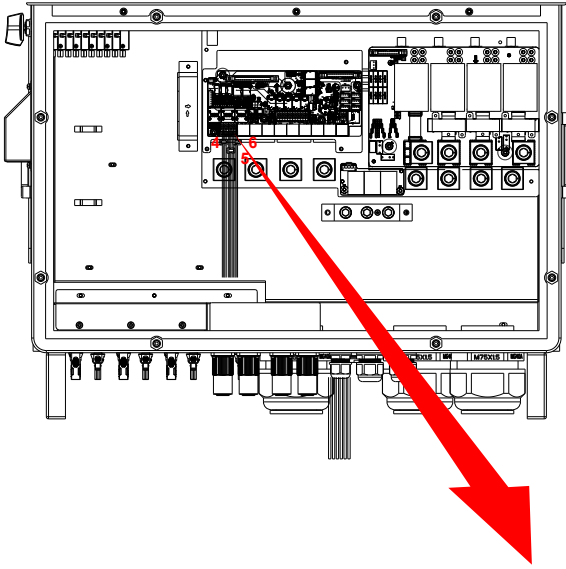

Thread the end of the CT's wires through the magnetic ring 4 and wrap the wires around it five lap. Fix the magnetic ring near the wiring terminals, as shown in the above diagram. Repeat this operation for the other two CTs.

3.4 Battery connection

For safe operation and compliance, a separate DC over-current protector or disconnect device is required between the battery and the inverter. In certain applications, a disconnect switch may not be necessary, but it is always essential to have DC overcurrent protection in place. Refer to the typical amperage in the **page 28** for the required fuse or circuit breaker size.

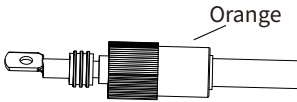

Pic 3.1 BAT+ plug connector

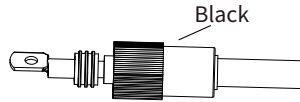

Pic 3.2 BAT- plug connector



Safety Hint:

Please use approved DC cable for battery system.

Model	Cross section (mm ²)	
	Range	Recommended value
SUN-100K-SG02HP3-EU-GM8/ SUN-100/125K-SG02HP3-EU-GM10	2AWG	25mm ²

Chart 3-2

The steps to assemble the battery plug connectors are listed as follows:

- a) Pass the cable through the terminal, as shown in Pic 3.3.

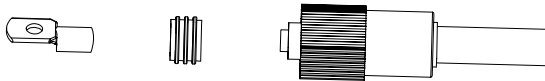

Pic 3.3

b) Put on the rubber ring, as shown in Pic 3.4.

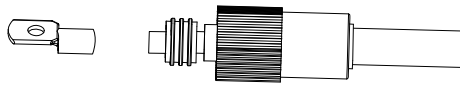

Pic 3.4

c) Crimp the metal terminal, as shown in Pic 3.5.

Hydraulic pliers

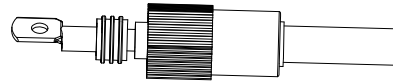

Pic 3.5

d) Fasten terminal with a bolt, as shown in Pic 3.6.

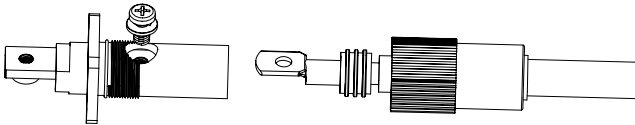

Pic 3.6

e) Fasten the terminal with outer cover, as shown in Pic 3.7.

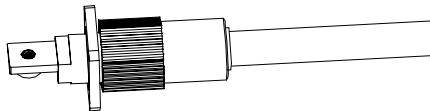

Pic 3.7

BMS connection

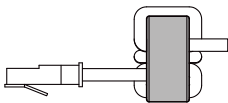

Thread the BMS communication cable through the magnetic ring 1,2 and wrap it around the magnetic ring four times.

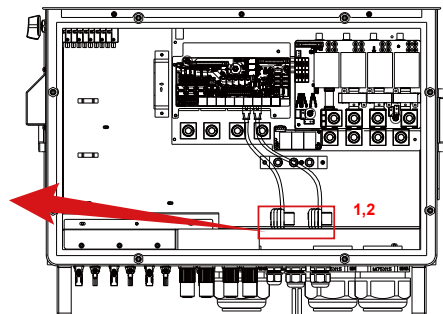

3.5 Grid connection and backup load connection

- Before connecting to the grid, a separate AC breaker must be installed between the inverter and the grid, and also between the backup load and the inverter. This will ensure the inverter can be securely disconnected during maintenance and fully protected from over current. Check the recommended values in the following tables according to local regulations in each country. The recommended specifications for AC breakers here are based on the Max. Continuous AC passthrough current of inverter, you can also choose the AC breaker of backup side according to the actual total operating current of all the backup loads.
- There are three terminal blocks with "Grid" "Load" and "GEN" markings. Please do not misconnect input and output connectors.

AC Breaker for backup load

Model	Recommended AC breaker
SUN-100K-SG02HP3-EU-GM8 SUN-100/125K-SG02HP3-EU-GM10	320A

AC Breaker for grid

Model	Recommended AC breaker
SUN-100K-SG02HP3-EU-GM8 SUN-100/125K-SG02HP3-EU-GM10	320A

Note:



In final installation, breaker certified according to IEC 60947-1 and IEC 60947-2 shall be installed with the equipment.

All wiring must be performed by a qualified personnel. It is very important for system safety and efficient operation to use appropriate cable for AC input connection. To reduce risk of injury, please use the proper recommended cable as below. There are two tables below, the first table recommends cable specifications based on bypass current (Max. Continuous AC passthrough), and the second table is based on Max. AC output current.

Grid connection and backup load connection (Copper wires) (bypass)

Model	Wire Size	Cross section(mm ²)	Torque value(max)
SUN-100K-SG02HP3-EU-GM8 SUN-100/125K-SG02HP3-EU-GM10	250kcmil	120	33.9 N.m

Grid connection and backup load connection (Copper wires)

Model	Wire Size	Cross section(mm ²)	Torque value(max)
SUN-100K-SG02HP3-EU-GM8 SUN-100/125K-SG02HP3-EU-GM10	250kcmil	120	33.9 N.m

Chart 3-3 Recommended Size for AC wires

Please follow below steps to implement Grid, load and Gen port connection:

1. Before making Grid, load and Gen port connection, be sure to turn off AC breaker or disconnecter first.
2. Strip the insulation of AC wires by about 10mm, insert AC wires according to polarities indicated on the terminal block and tighten the terminals. Be sure to connect corresponding N wires and PE wires to related terminals as well.

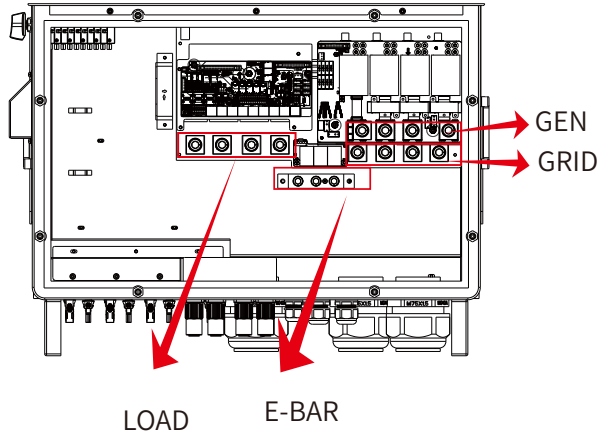
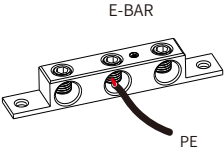
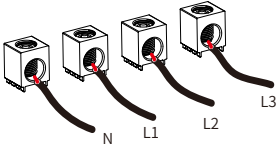



Be sure that AC power source is disconnected before attempting to wire it to the unit.

3. Make sure all the wires are securely and completely connected.

4. Some appliances, such as air conditioners and refrigerators, may need a time delay before reconnecting them after a power outage. This delay allows the refrigerant gas to stabilize and prevents potential damage. Check if your appliance has a built-in time-delay function before connecting it to our inverter. Examples of appliances that may require a delay include:

Air conditioners: Balancing refrigerant gas.

Refrigerators: Stabilizing the compressor.

Freezers: Allowing the cooling system to balance.

Heat pumps: Protecting against power fluctuations.

This inverter will protect your appliances by triggering an overload fault if no time delay is present. However, internal damage may still occur. Refer to the manufacturer's documentation for specific time-delay requirements.

3.6 PV Connection

Before connecting to PV modules, please install a separately DC circuit breaker between inverter and PV modules. It is very important for system safety and efficient operation to use appropriate cable for PV module connection.



To avoid any malfunction, do not connect any PV modules with possible leakage current to the inverter. For example, grounded PV modules will cause leakage current to the inverter. When using PV modules, please ensure the PV+ & PV- of solar panel is not connected to the system ground bar.



It is requested to use PV junction box with surge protection. Otherwise, it will cause damage on inverter when lightning occurs on PV modules.

3.6.1 PV Module Selection:

When selecting proper PV modules, please be sure to consider below parameters:

- 1) Open circuit Voltage (Voc) of PV modules can not exceed max.PV Input Voltage of inverter.
- 2) Open circuit Voltage (Voc) of PV modules should be higher than min.PV Input Voltage of inverter.
- 3) The PV modules used to be connected to this inverter shall be Class A rating certified according to IEC 61730.

Inverter Model	SUN-100K-SG02HP3-EU-GM8	SUN-100/125K-SG02HP3-EU-GM10
PV Input Voltage	650V (180V-1000V)	
PV Array MPPT Voltage Range	150V-850V	
No. of MPP Trackers	8	10
No. of Strings MPP Tracker	2+2+2+2+2+2+2+2	2+2+2+2+2+2+2+2+2+2

Chart 3-5

3.6.2 PV Module Wire Connection:

1. Switch the Grid Supply Main Switch(AC)OFF.
2. Switch the DC Isolator OFF.
3. Assemble PV input connectors to the inverter.



Safety Hint:

Before connection, please make sure the polarity of PV array matches the "DC+" and "DC-" symbols.



Safety Hint:

Before connecting to inverter, please make sure that the open circuit voltage of PV strings haven't exceeded the max.PV input voltage of the inverter.

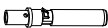
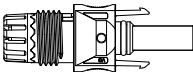

Pic 5.1 DC+ male connector



Pic 5.2 DC- female connector



Safety Hint:

Please use approved DC cable for PV system.

Cable type	Cross section (mm ²)	
	Range	Recommended value
Industry generic PV cable (model: PV1-F)	2.5-4 (12-10AWG)	2.5(12AWG)

Chart 3-6

The steps to assemble the PV connectors are listed as follows:

a) Strip the insulation of the PV wire by 7 mm, disassemble the cap nut of the connector, thread one PV wire through the cap nut of the connector (see Pic 5.3). Repeat this operation with all the PV wires, paying special attention to the polarity of the connector.

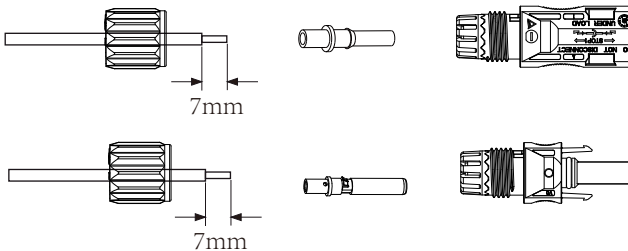

Pic 5.3 Disassemble the connector cap nut

b) Crimping metal terminals with crimping pliers, as shown in Pic 5.4.



Pic 5.4 Crimp the contact pin to the wire

c) Insert the contact pin to the top part of the connector and completely tighten the cap nut to the top part of the connector, as shown in Pic 5.5.

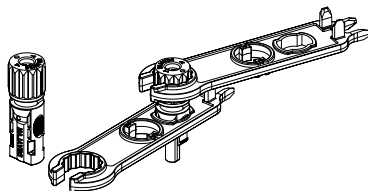

Pic 5.5 connector with cap nut screwed on

d) Finally insert the PV connectors into the positive and negative PV inputs of the inverter, as shown in Pic 5.6.

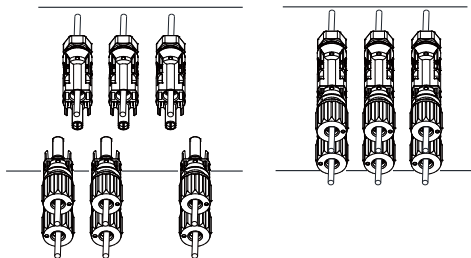

Pic 5.6 DC input connection



Warning:

When operating the PV strings, be aware that sunlight exposure can generate high voltages in the PV strings. Avoid contact with exposed electrical connectors or terminals to prevent electrical shock or injury. For safety, it is best to operate the PV strings at night or when PV modules are not exposed to sunlight. If daytime operation is necessary, cover the PV modules to minimize sunlight exposure and prevent high voltage generation. Remember to turn off the DC breaker or switch before performing any maintenance or adjustments. Do not turn off the DC breaker or switch when high voltage or high current is present to avoid damage or hazards. Prioritize personal safety.



Warning:

Please use its own DC power connector from the inverter accessories. Do not interconnect the connectors of different manufacturers. The I_{sc} current of PV modules should not exceed the Max.PV I_{sc} current of this inverter. If exceeds, it may damage the inverter and is not covered by Deye's warranty.

3.7 Meter or CT installation

There are three selectable installation methods to measure the power consumption or to ensure zero power export to grid. The default installation method is to use the CTs (300A/5A) that come with the packaging box. When the distance between the AC distribution box and the hybrid inverter exceeds 10 meters, which means that the wire length of the CT needs to exceed 10 meters, it is recommended to use a smart meter instead of three CTs. In addition, in a parallel system, if the current to be measured is greater than 300 A, the default three CTs also need to be replaced with smart meters or larger CTs. Please contact the Deye support team to confirm which specification of CT or smart meter to use.

3.7.1 CT connection

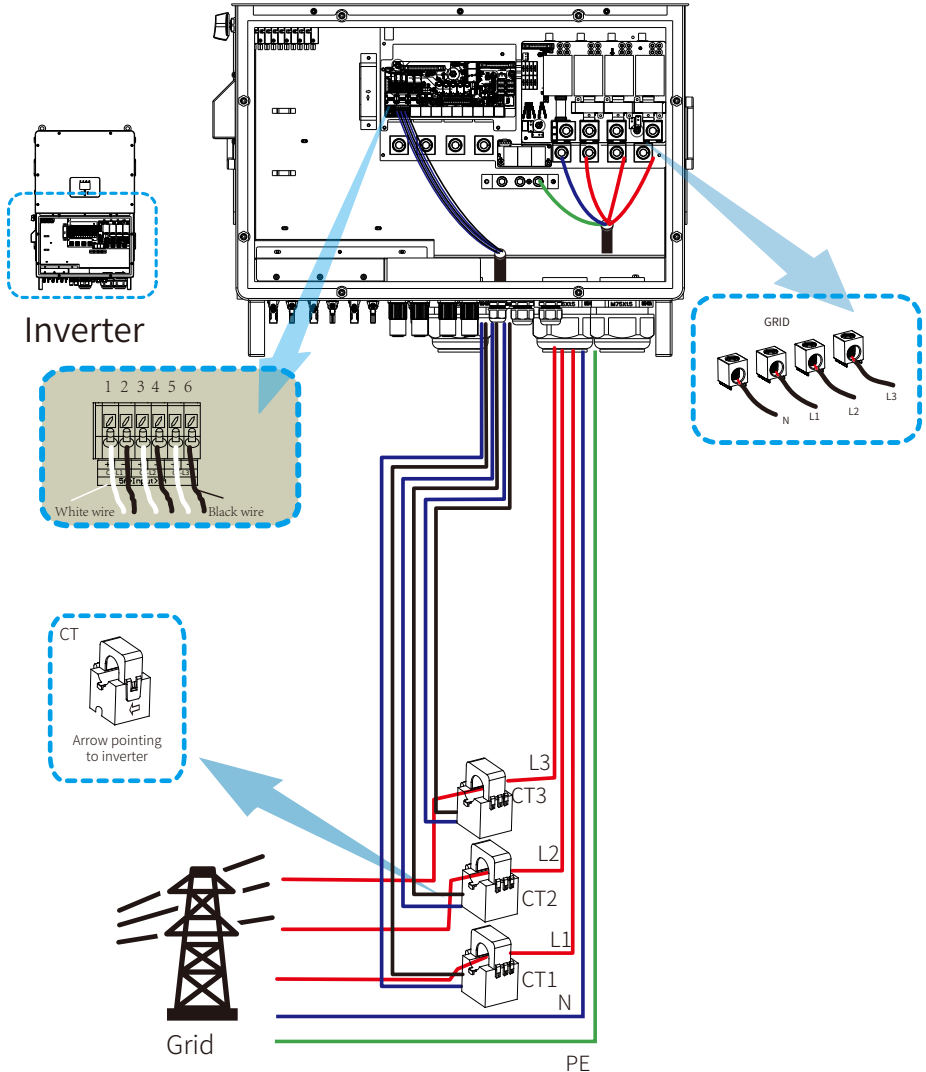

***Note: When taking power from the utility grid, if the grid power displayed on the LCD screen is indeed negative, please adjust the installation direction of the CTs. Please refer to Chapter 3.10 for the position to be clamped.**

3.7.2 Meter connection with CTs

Due to Max. Continuous AC Passthrough (grid to load) is 200A, so only transformer meter which can measure higher current is recommended to be installed. The smart meter brands that Deye inverters have been matched with include CHINT and Easton, The recommended models here are not all compatible models, It is recommended to purchase smart meter from authorized distributors of Deye, otherwise it may not be able to be used due to communication mismatch. The definition of the "Meter" port can be found in the Appendix part which is in the end of this user manual.

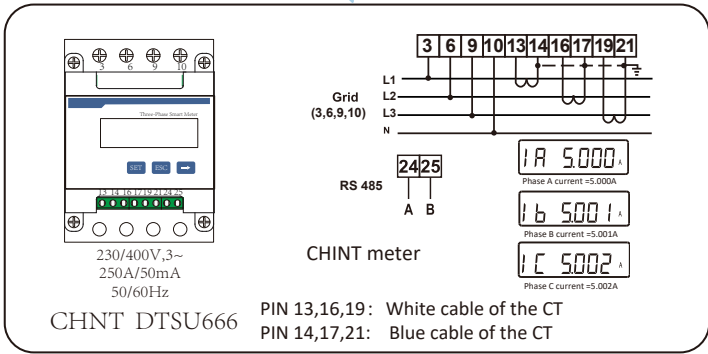
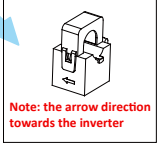
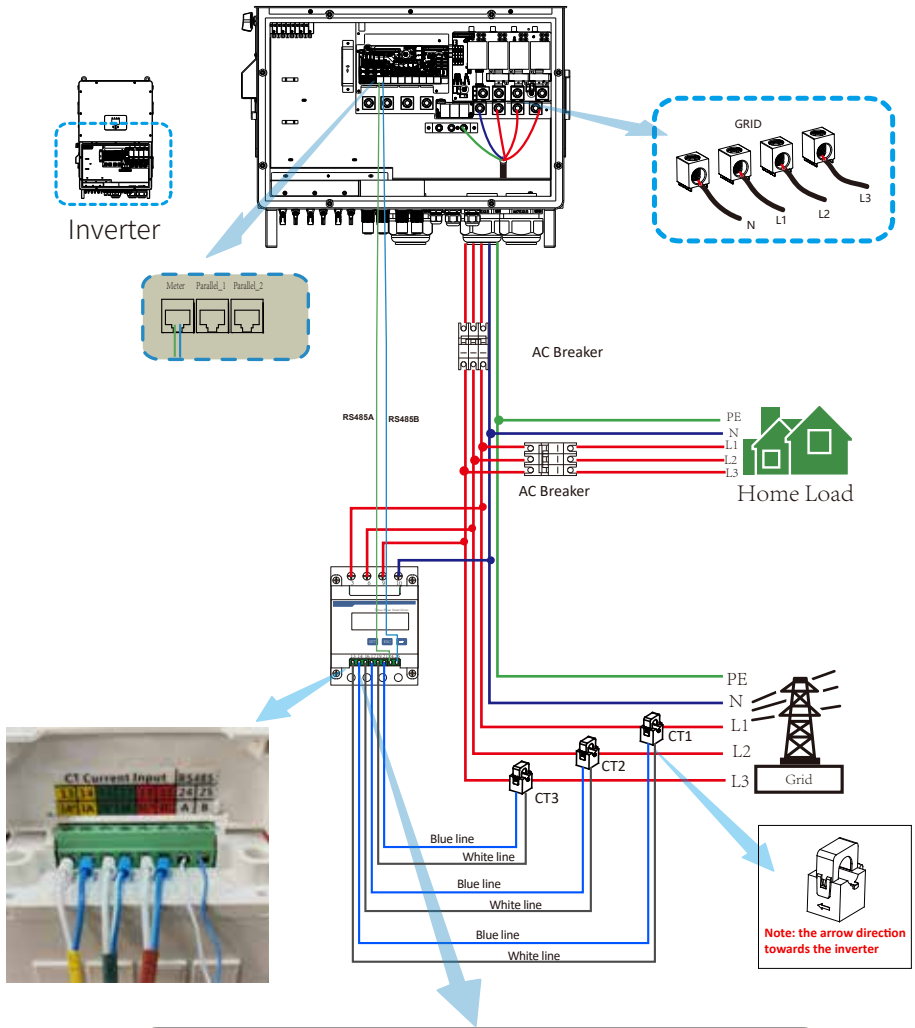

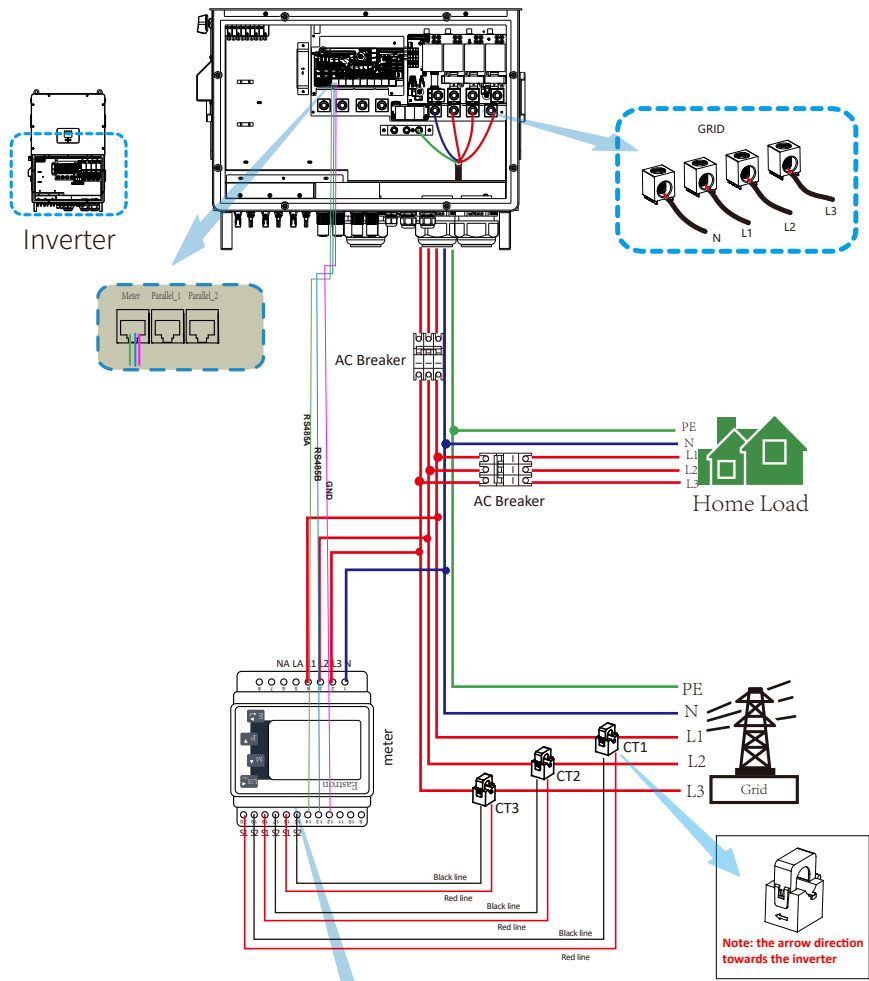

Note: the arrow direction towards the inverter

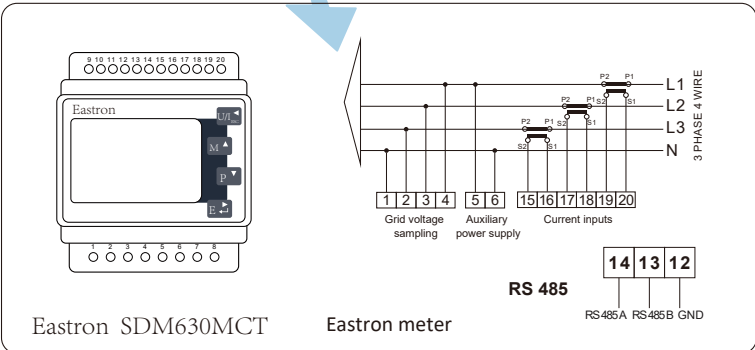

Meter connection

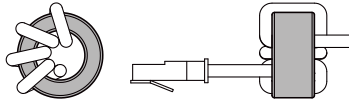
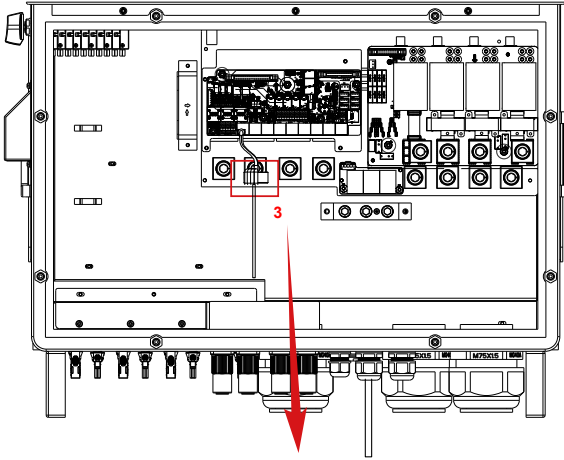

Thread the meter communication cable through the magnetic ring 3 and wrap it around the magnetic ring four times.

3.8 Earth Connection(mandatory)

The PE wires of AC cables(if have) shall connect to the E-Bar inside the junction box of the inverter, and the ground hole on the shell of the inverter shall be connected to the external ground plate.

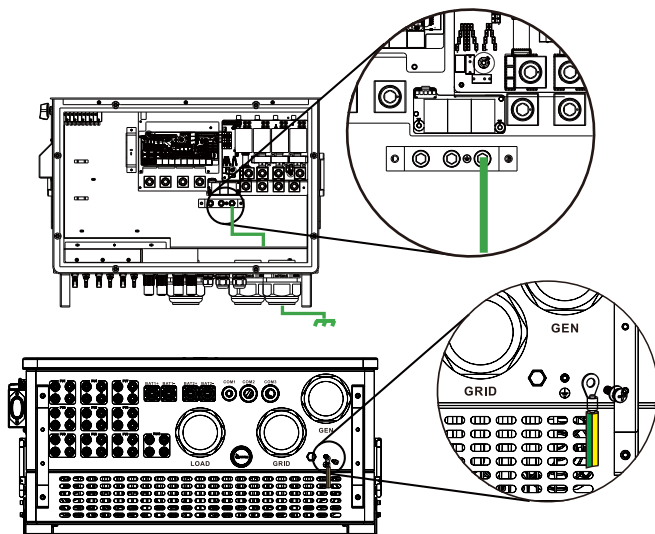

Earth Connection (Copper wires) (bypass)

Model	Wire Size	Cross section(mm ²)	Torque value(max)
SUN-100K-SG02HP3-EU-GM8 SUN-100/125K-SG02HP3-EU-GM10	3/0AWG	70	31 N.m

Earth Connection (Copper wires)

Model	Wire Size	Cross section(mm ²)	Torque value(max)
SUN-100K-SG02HP3-EU-GM8 SUN-100/125K-SG02HP3-EU-GM10	3/0AWG	70	31 N.m

The conductor should be made of the same metal as the phase conductors.



Warning:

Inverter has built-in leakage current detection circuit, The type A RCD can be connected to the inverter for protection according to the local laws and regulations. If an external leakage current protection device is connected to the grid port of inverter, please refer to section 3.11, its operating current must be equal to 10mA/KVA or higher, for this series of inverter it should be 1250mA or higher, otherwise inverter may not work properly.

3.9 Data logger connection

For the configuration of data logger, please refer to the user manual of data logger. Wi-Fi logger is not the only option, If the installation location does not have Wi-Fi signal or the signal is weak, you can also choose a data logger that communicates via other interfaces.

3.10 Wiring diagram with neutral line grounded

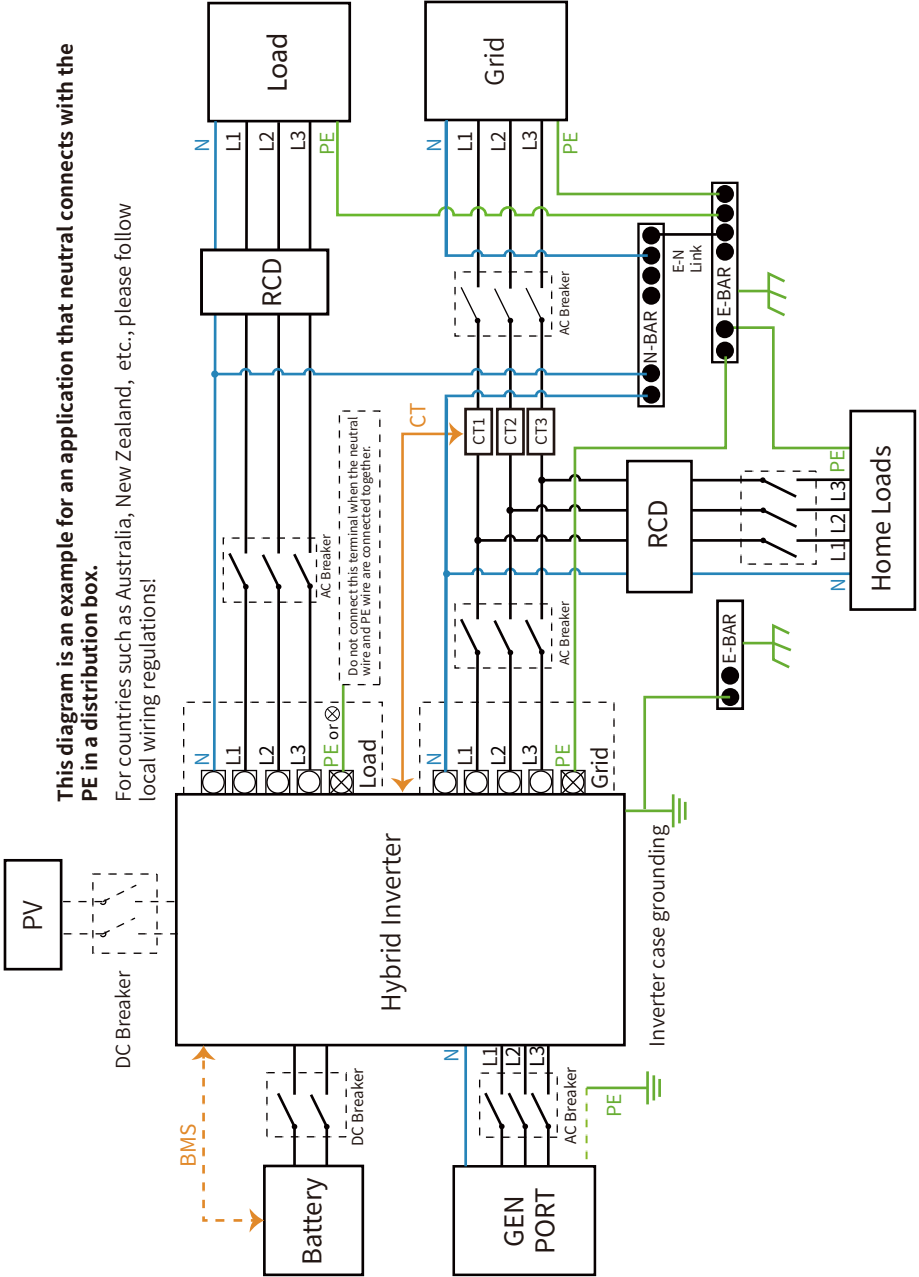

3.11 Wiring diagram with neutral line ungrounded

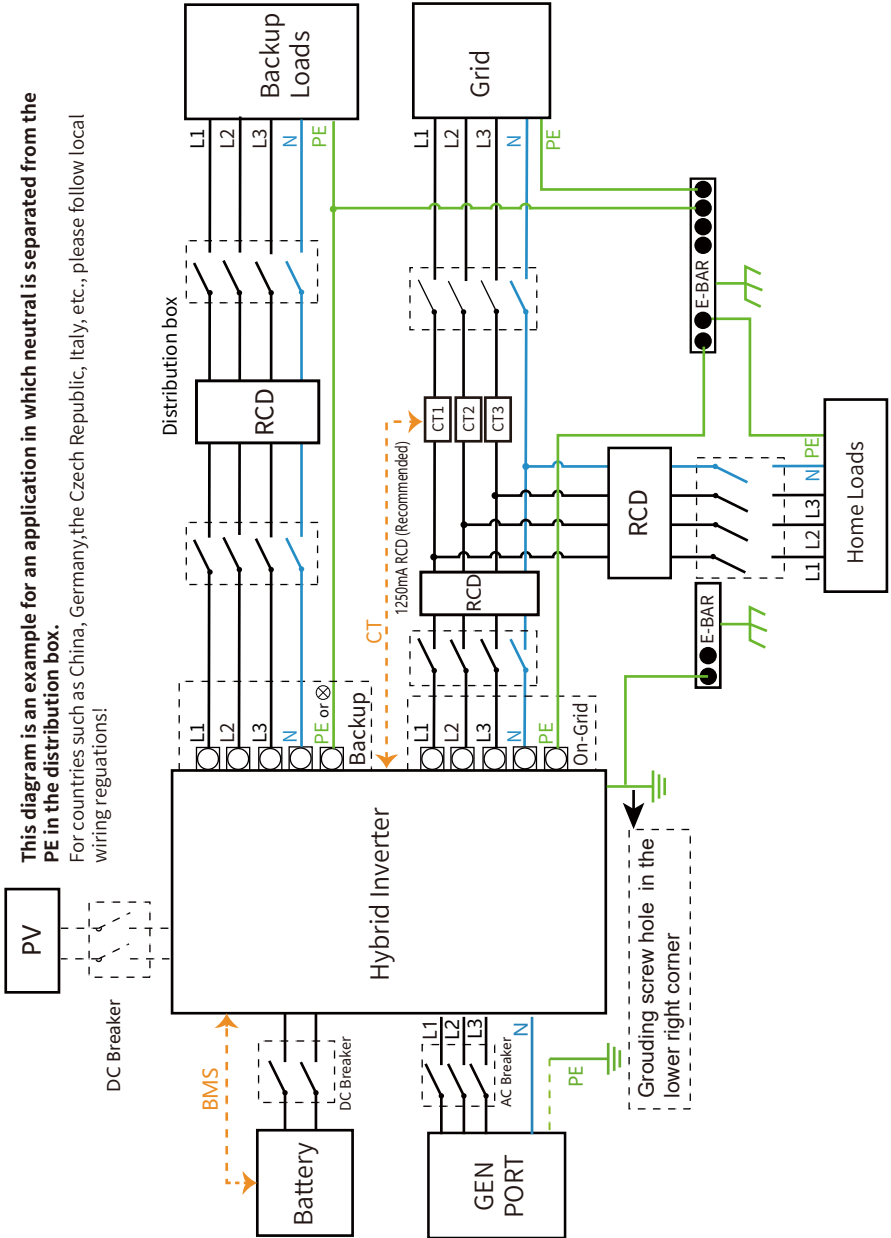

3.12 Typical application diagram of on-grid system

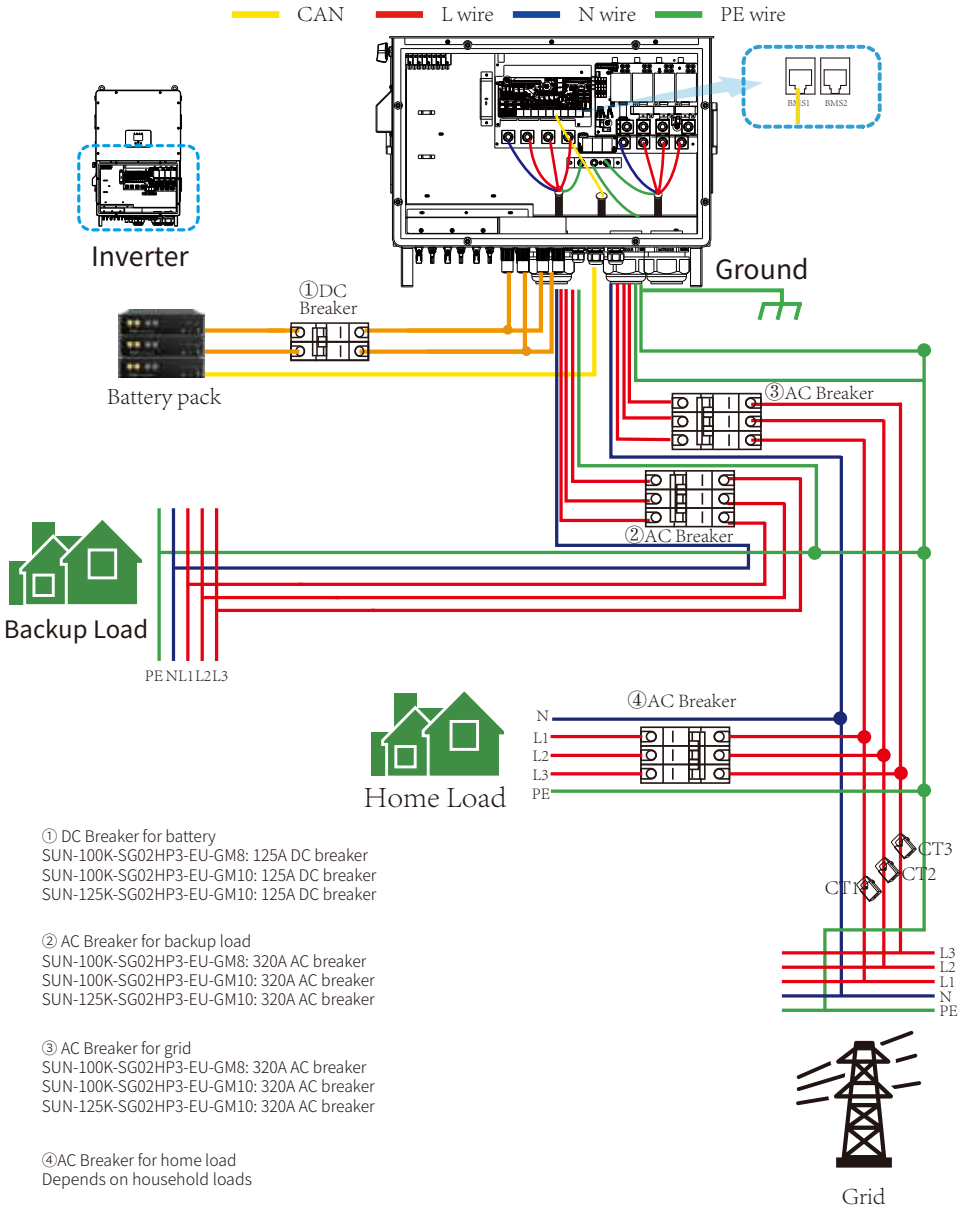

3.13 Typical application diagram of diesel generator

— CAN — L wire — N wire — PE wire

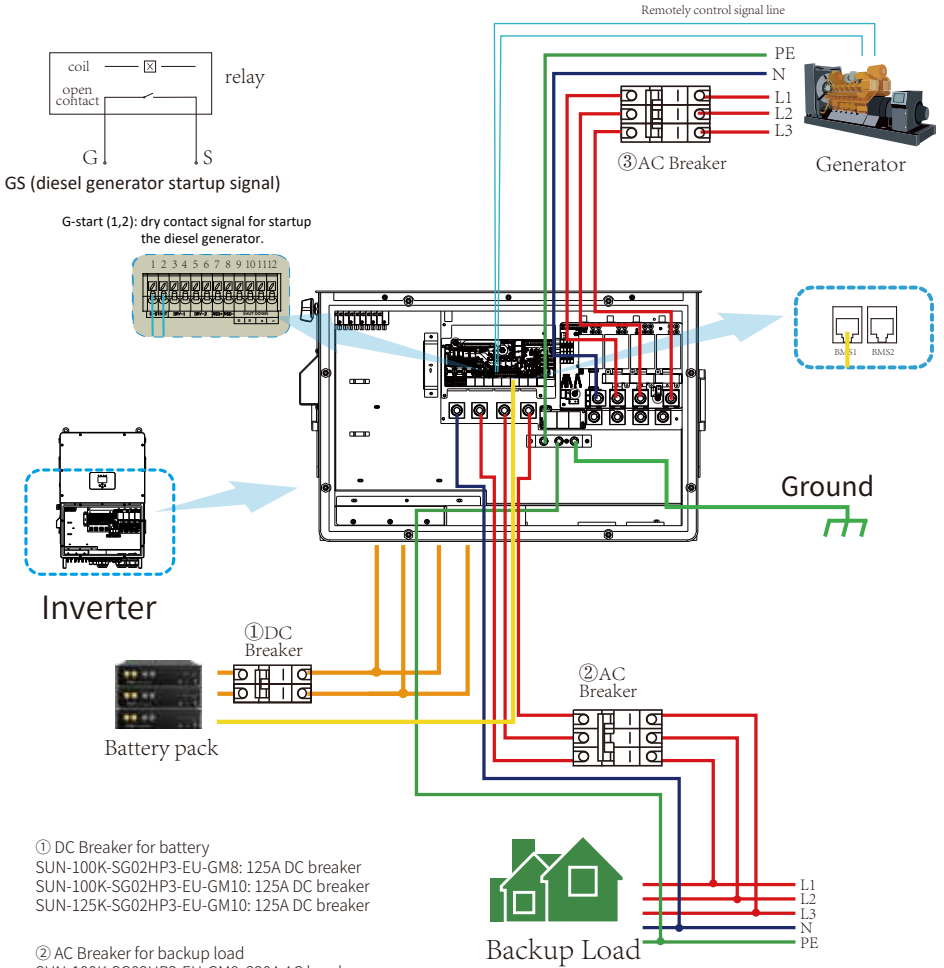

① DC Breaker for battery
 SUN-100K-SG02HP3-EU-GM8: 125A DC breaker
 SUN-100K-SG02HP3-EU-GM10: 125A DC breaker
 SUN-125K-SG02HP3-EU-GM10: 125A DC breaker

② AC Breaker for backup load
 SUN-100K-SG02HP3-EU-GM8: 320A AC breaker
 SUN-100K-SG02HP3-EU-GM10: 320A AC breaker
 SUN-125K-SG02HP3-EU-GM10: 320A AC breaker

③ AC Breaker for Generator port
 SUN-100K-SG02HP3-EU-GM8: 320A AC breaker
 SUN-100K-SG02HP3-EU-GM10: 320A AC breaker
 SUN-125K-SG02HP3-EU-GM10: 320A AC breaker

3.14 Three phase parallel connection diagram

Note: For the parallel system, the lead-acid battery and 'No Batt' mode are not supported. All inverters connected in parallel must be the same model. Please use lithium battery which is on the "Deye Approved Battery list". Each inverter should have its own separate battery set.

Note: For the parallel system, please choose the "Zero export Partial Backup" mode. Only the master inverter needs to be installed CT.

Legend: CAN (Yellow), L wire (Red), N wire (Blue), PE wire (Green)

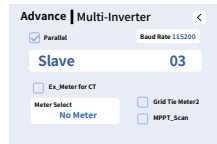
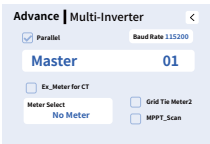
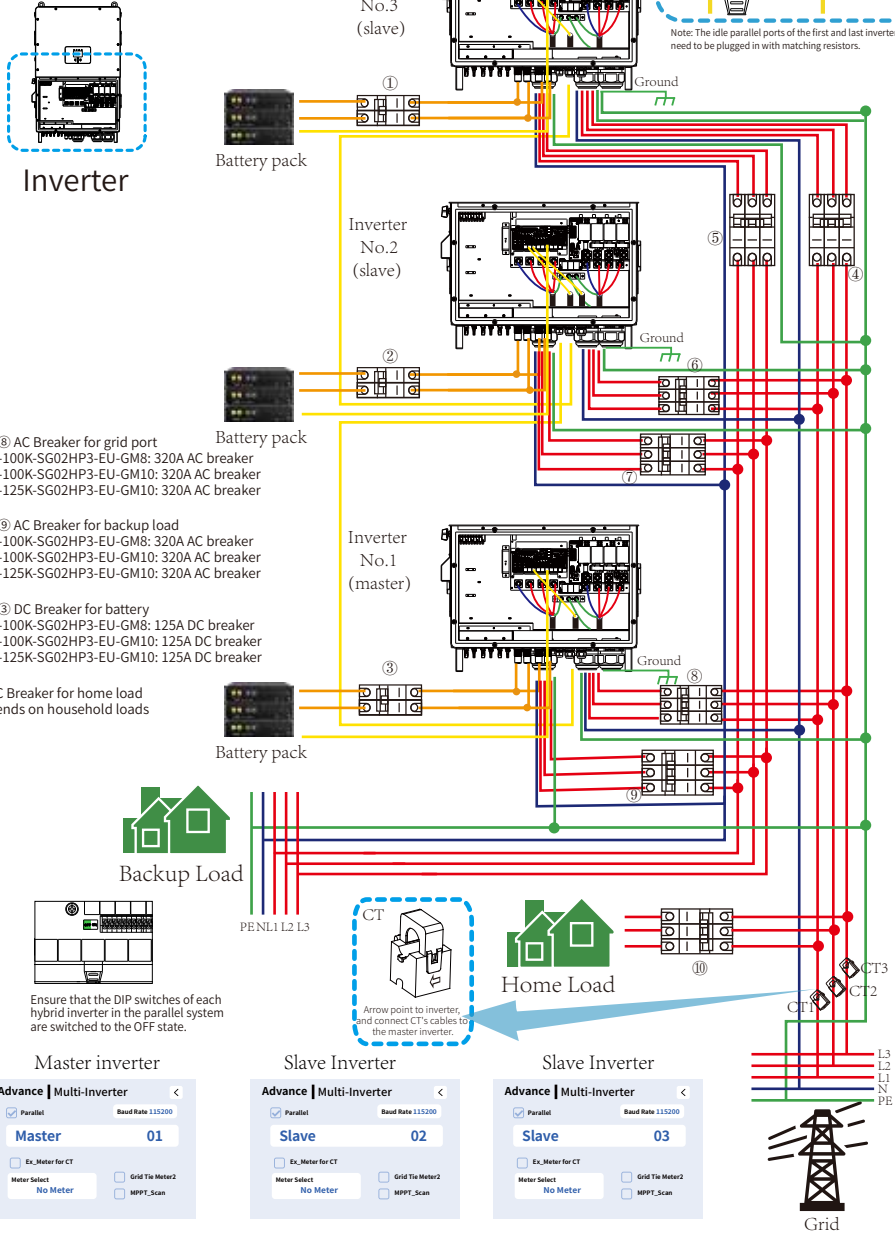
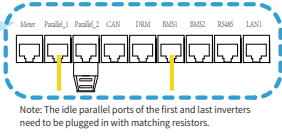

4. OPERATION

4.1 Power ON/OFF

Once the system has been properly installed and the battery is connected to the inverter, follow the steps below to turn on the inverter:

1. Turn all the breakers of the installation on.
2. Turn on the DC switches of the inverter and the power button of battery (If there is one battery installed at the system), no matter the order.
3. Press the ON/OFF button (located on the left side of the inverter case) to turn on the inverter. When a system connected to either PV or Grid (without battery) is switched on, the LCD will still be lighted up displaying "OFF". In this situation, after switching ON/OFF button on, select "NO batt" at the inverter settings to make the system work.

When turning off the inverter, please follow the following steps:

1. Turn off the AC breakers on Grid port, Load port and GEN port.
2. Press the ON/OFF button of hybrid inverter and turn off the DC breaker on battery side, then turn off the power button of the battery.
3. Switch off the DC switches of the inverter.

4.2 Operation and Display Panel

The operation and display panel, shown in below chart, is on the front panel of the inverter. It includes four indicators, four function keys and a LCD display, indicating the operating status and input/output power information.



LED Indicator		Messages
DC	Green led solid light	PV Connection normal
AC	Green led solid light	Grid Connection normal
Normal	Green led solid light	Inverter operating normal
Alarm	Red led solid light	Malfunction or warning

Chart 4-1 LED indicators

Function Key	Description
Esc	To exit setting mode
Up	To go to previous selection
Down	To go to next selection
Enter	To confirm the selection

Chart 4-2 Function Buttons

5. LCD Display Icons

5.1 Main Screen

The LCD is touchscreen, below screen shows the overall information of the inverter.

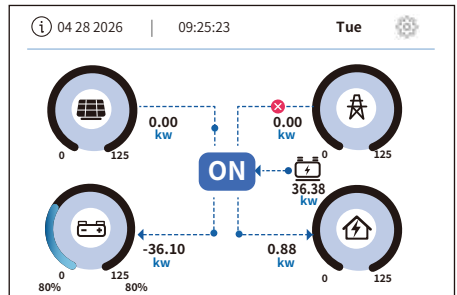
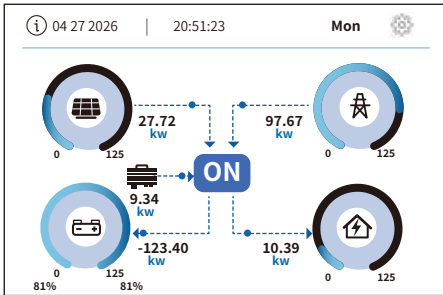

1.The icon at the center of the screen indicates whether the system is under normal operation or not, displaying "ON" for normal status or displaying a code like "Comm./F01-F64" for communication errors or other errors. Please refer to the Error code list of alarms and errors in chapter 8 to find out solutions about the error.

2. On the left side of the top of the inverter's LCD screen is the local date and time. To ensure the correct timestamp recording of historical data on the cloud server, please set it to the correct local time or synchronize it with the cloud server during debugging.

3.Click the gear icon in the upper right corner of the inverter's LCD home screen to access the inverter's 'Setting' menu page. In the Setting page, there are multiple interactive settings options.

4.The main screen includes the icons for PV(left up), grid (right up), on-grid inverter(ightly to the left of center), generator(ightly to the right of center), load(right bottom), and battery (left bottom). It also displays the energy flow direction by moving dots and arrows. When the power is approaching to a high level, the color on the panels will change from black to blue, showing vividly the system status on the main screen.

Some clarifications about the system status are as follows:

- PV power will always be positive.
- In single inverter system, load power will always be positive. In a parallel system, the load power may be negative, which means that the other inverters supply power to this inverter through the load port.
- A negative Grid power means energy being exported to the grid (sold), whereas positive means energy being imported from the grid (purchased).
- Negative battery power means charging, positive means discharging.

The icon for the on-grid inverter, positioned slightly to the left of center, will only appear when the conditions for connecting the on-grid inverter are met. Similarly, the generator icon located slightly to the right of center becomes visible only after the generator connection conditions are satisfied and the G-S dry contact is closed.

"Forced" is displayed between the inverter icon and the Load icon, indicating that the smart load has been manually enabled by long-pressing the wave icon in the lower-left corner of the Load detail page.

In contrast, if the smart load is activated automatically only when the battery SOC reaches the ON threshold, "smart" will be shown between the two icons instead.

5.1.1 LCD operation flow chart

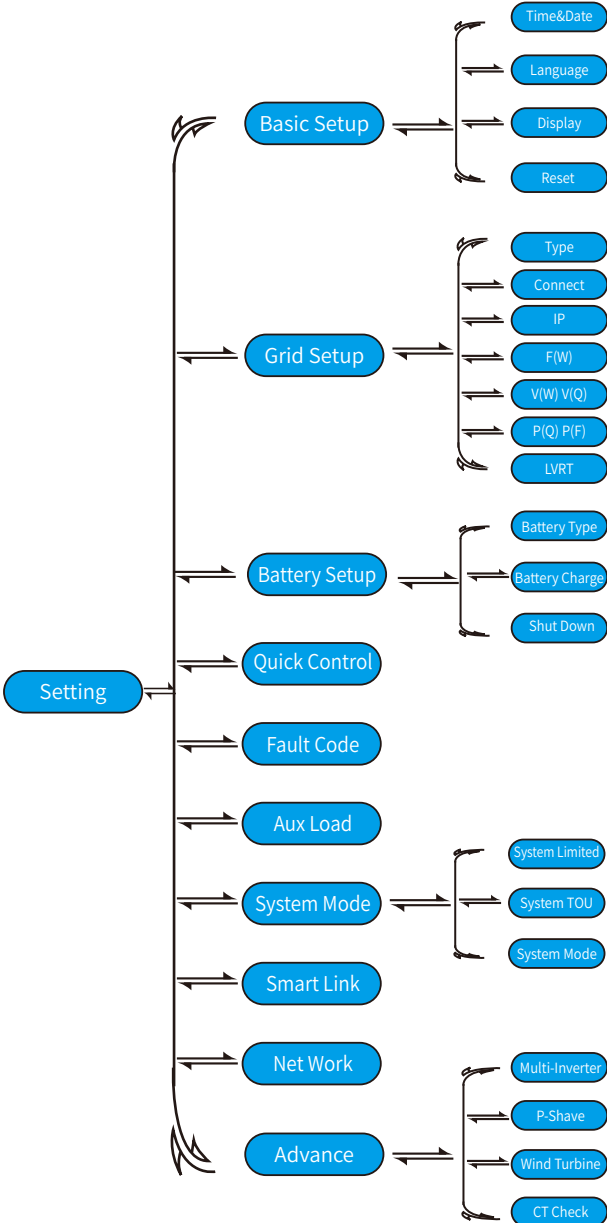

5.2 Detail page

Click the icons on main screen of LCD display, you can enter the detail pages of "Solar", "Grid", "On-grid inverter", "Detail", "Generator", "Battery" and "Load".

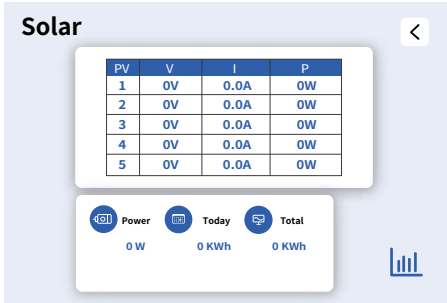

This is Solar Panel detail page.

Voltage, Current, Power for each MPPT.

Generation power.

Daily and total PV production.

Click the bar chart icon at the bottom right corner of the page to view the historical data chart of PV power generation.

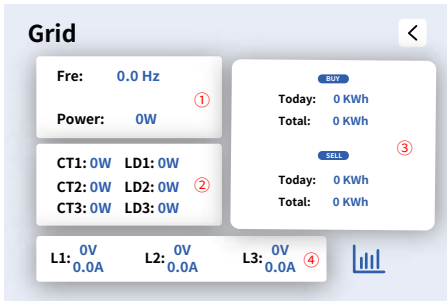

This is Grid detail page.

① Grid Frequency, Grid power

② CT1/2/3:
LD1/2/3:

③ The electricity purchased from the grid on the current day and the total historical purchased electricity; The electricity sold to the grid on the current day and the total historical sold electricity.

④ The voltage and current of each phase of the grid. Click the bar chart icon at the bottom right corner of the page to view the historical data chart of Grid power consumption.

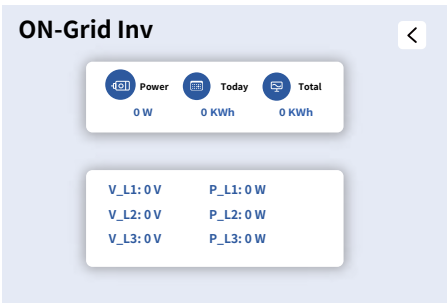

The upper section displays the on-grid inverter's current output power, daily energy generation, and total energy generation. The lower section shows the voltage and output power of each phase on the output side of the on-grid inverter.

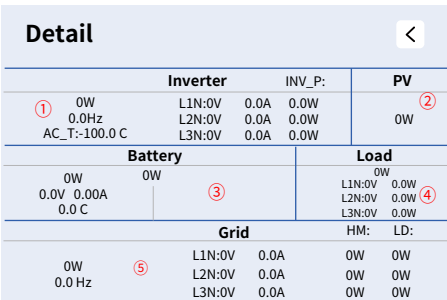

This is Inverter detail page.

① **DC/AC inverter module:** output power, output frequency, AC_T (The higher one of the two temperature sensor sampling data). The voltage, current, and power output of inverter module's each phase.

② **PV:** Solar generation power

③ **Battery:** Charging/Discharging power

The battery voltage, current, and temperature data sampled by the inverter.

④ **Load:** Total Load consumption power

The voltage and load power of each phase at the inverter's Load port.

⑤ **Grid:** Grid voltage, Grid Frequency.

The voltage and current of each phase at the inverter's Grid port.

HM: The power of each phase at the sampling point calculated using the sampling data from an external CT/meter.

LD: The power of each phase at the internal sampling point, calculated using data sampled by the inverter's Grid port built-in sampling circuit.

Generator

Power
0 W

Today
0 KWh

Total
0 KWh

V_L1: 0 V

V_L2: 0 V

V_L3: 0 V

P_L1: 0 W

P_L2: 0 W

P_L3: 0 W

The upper section displays the generator's current output power, daily energy generation, and total energy generation. The lower section shows the voltage and output power of each phase on the output side of the generator.

Battery

Battery1

Status: Stand by

SOC: 0%

U: 0.0V

I: 0.00A

Power: 0W

Temp: 0.0C

Battery2

Status: Stand by

SOC: 0%

U: 0.0V

I: 0.00A

Power: 0W

Temp: 0.0C

Li BMS

Li BMS1: Deye

Voltage: 0.0V

Current: 0.0A

Temp: -100.0C

SOC: 0% SOH: 0%

Capacity: 0Ah

Charge Voltage: 0.0V

Charge Current: 0A

Discharge Current: 0A

Almars: 0x0000 0x0000

Li BMS2: Deye

Voltage: 0.0V

Current: 0.0A

Temp: -100.0C

SOC: 0% SOH: 0%

Capacity: 0Ah

Charge Voltage: 0.0V

Charge Current: 0A

Discharge Current: 0A

Almars: 0x0000 0x0000

This is Battery detail page.

BATTERY DETAIL PAGE

Click the BMS icon on the lower right corner of Battery detail page, you can enter the BMS page.

Load

Power ①
0W

Today ③
0KWh

Total ③
0KWh

L1: 0V

L2: 0V

L3: 0V

P1: 0W

P2: 0W ②

P3: 0W

- ① Load Power.
- ② Voltage, Power for each Phase.
- ③ Daily and total Load consumption .

When the inverter operates in 'Selling First' or 'Zero Export to load' modes, the Load power data includes only the Backup load. When the inverter operates in 'Zero Export to CT' mode, the Load power data includes both the Backup Load and Home load.

Long press the wave icon at the bottom left corner of this page to force the main relays of the GEN port to engage so that the inverter can supply power to the smart load.

Click the bar chart icon at the bottom right corner of the page to view the historical data chart of Load power consumption.

5.3 Curve Page-Solar & Load & Grid

In the home screen of LCD display, click the icons of "Solar", "Grid" and "Load", you can enter the detail pages of Solar power, Grid power and Load consumption. Click the bar chart icon on the lower right corner of these detail pages, you can enter the curve page. Using PV as an example for illustration below.

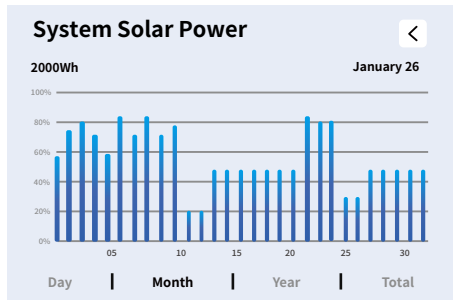
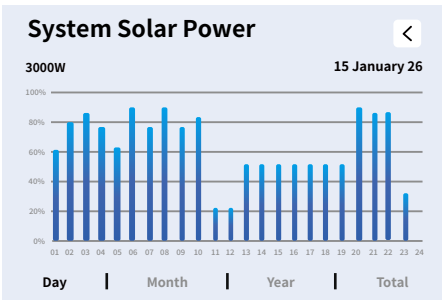
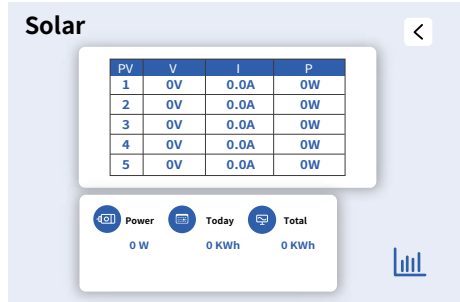
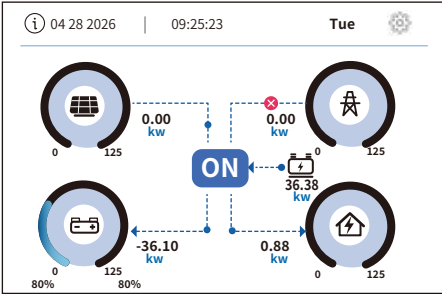

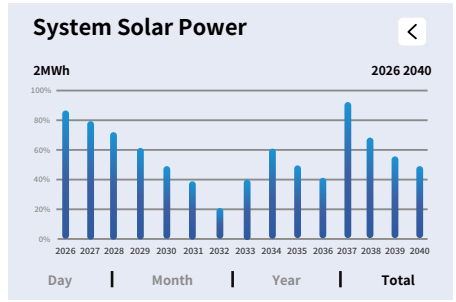
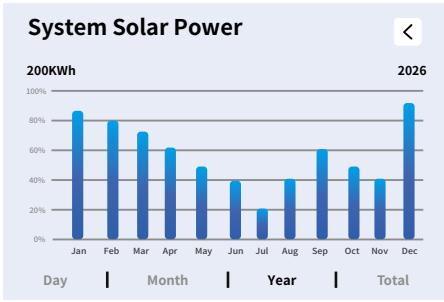

Solar power curve for daily, monthly, yearly and total can be roughly checked on the LCD, for more accuracy power generation, please check on the APP or website of the cloud platform. Click the up and down buttons below the LCD screen to view the power curves of different time periods. The operation of checking the grid power and load power is similar to the above operation.

5.4 Setting Menu

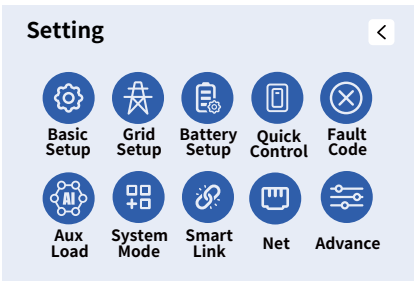

This is the system setting menu page, containing 10 settings items.

5.5 Basic setup Menu

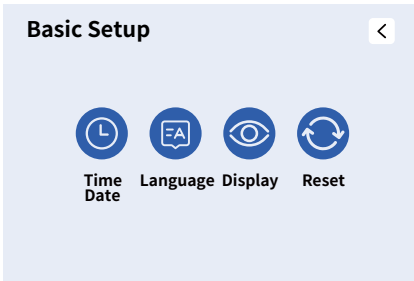

Click the 'Basic Setup' item on the 'Setting' page to enter this 'Basic Setup' page, this page contains 4 sub-settings.

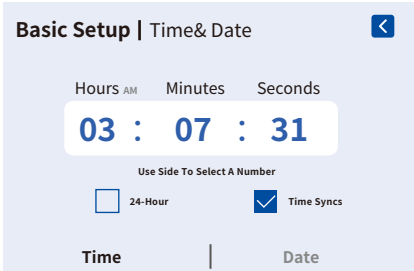

Click the 'Time&Date' sub-setting on the 'Basic Setup' page to enter this page.
Time&Date: Slide up and down the corresponding screen area to adjust the time to match the local time, and then go to the date page and adjust the date using the same method.
24-Hour: Use 24-hour format.
Time Syncs: Automatic Time Sync with Cloud Server.

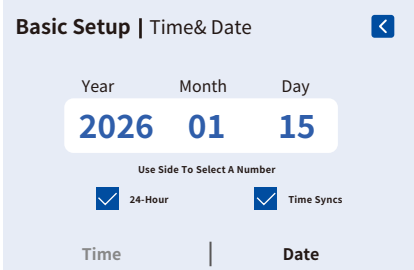

Click the 'Language' sub-setting on the 'Basic Setup' page to enter this page.

If the display language you want is available on the LCD screen, please select it directly. If not, please contact the after-sales support team to confirm whether the desired display language can be supported via a language package upgrade.

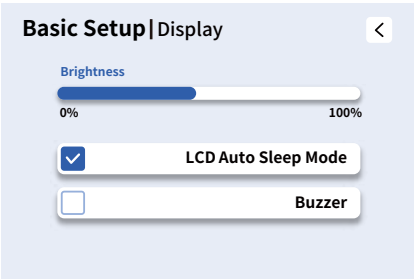

Brightness: Adjust the LCD screen brightness by dragging the progress bar left or right.
LCD Auto Sleep Mode: When enabled, the LCD will automatically enter sleep mode after 5 minutes of inactivity.
Buzzer: When enabled, the buzzer will sound during fault alarm periods.

Basic Setup | Reset



Factory Reset

Lock All Changes

Factory Reset: Restore all parameters to factory defaults and delete all historical data.

Lock All Changes: After enabling, all parameters will be locked and cannot be modified.

Pass Key Required



+	-	*	/
1	2	3	↵
4	5	6	✖
7	8	9	↶
,	0	.	

When we select the "factory reset" or "Lock all changes", the system will require you to enter a password first to confirm the operation.

Factory Reset Password: 9999

Lock all changes Password: 7777

5.6 Grid Setup Menu

Grid Setup

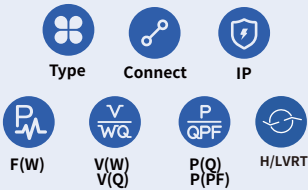

Click the 'Grid Setup' item on the 'Setting' page to enter this 'Grid Setup' page, this page contains 7 sub-settings.

Grid | Type



Press UP or DOWN button to switch option.

General Standard ⓘ

0/37

Mode | Frequency | Type | INV Output Voltage

Click the 'Type' sub-setting on the 'Grid Setup' page to enter this page.

ⓘ: Press UP or DOWN button to select the desired 'Grid Code'.

Grid | Type <

50 Hz
 60 Hz

Mode | **Frequency** | Type | INV Output Voltage

In scenarios with a power grid or generator, set this parameter according to the grid or generator frequency; In off-grid scenarios without a grid or generator, set this parameter according to the load's rated frequency.

Grid | Type <

0/120/240
 0/240/120

IT_system-neutral is not grounded

Mode | **Frequency** | **Type** | INV Output Voltage

0/120/240: Select this setting when the three live wires of the power grid are connected in L1/L2/L3 (L2/L3/L1,L3/L1/L2)sequence.
0/240/120: After grid connection, if the inverter alarms W03, change the grid phase sequence from '0/120/240' to this option.
IT_system-neutral is not grounded: When the system's power grid is a three-phase three-wire IT-type grid, please enable this option.

Grid | Type <

INV Output Voltage

LN:220VAC LL:380VAC

Mode | **Frequency** | Type | **INV Output Voltage**

In scenarios with a power grid or generator, set this parameter according to the grid or generator voltage. In off-grid scenarios without a grid or generator, set this parameter according to the backup load's rated voltage.

Grid | Connect <

Normal Ramp rate 00 S

Normal Connect | Reconnect After Trip | Other

Click the 'Connect' sub-setting on the 'Grid Setup' page to enter this page.
Normal Ramp rate(s): The time required for the inverter's output power to increase from zero to its rated output power during normal startup.

Grid | Connect <

Low Frequency	0.00 Hz	High Frequency	0.00 Hz
Low Voltage	0.0 V	High Voltage	0.0 V
Reconnect Ramp Rate	00 S	Reconnection Time	0 S

Normal Connect | **Reconnect After Trip** | Other

Low Frequency: Grid frequency lower limit for grid connection
High Frequency: Grid frequency upper limit for grid connection
Low Voltage: Grid voltage lower limit for grid connection
High Voltage: Grid voltage upper limit for grid connection
Reconnect Ramp Rate: It is the reconnection power ramp.
Reconnect Time: The waiting time for the inverter connects the grid again after tripping.

Grid | Connect <

Keyboard Low Frequency

45.00 Hz Min- 0.00 Hz Value 0.00 Hz Max+

+
-

OK Cancel

Normal Connect | **Reconnect After Trip** | Other

Methods to set the parameter values for the above Low/High Frequency and Low/High Voltage:
 (1) Click the 'Keyboard' button in the top-left corner to use the pop-up keyboard for entering the desired value.
 (2) Drag the progress bar left or right on the screen to the desired value position.
 (3) Click or long-press the '+' or '-' button on the right side of the LCD or the UP/DOWN physical button to adjust the value.
 After adjusting the value, click the 'OK' button on the LCD or the physical 'Enter' key to confirm and save, or click the 'Cancel' button on the LCD or the physical 'Esc' key to cancel the changes and return.

Grid | Connect <

Cosphi

0.000

Normal Connect | **Reconnect After Trip** | Other

Cosphi: Power factor. When the power factor is set to a positive value, the inverter absorbs reactive power from the grid; when power factor is set to a negative value, the inverter can deliver reactive power to the grid.

Grid | Ip <

Over Voltage U (10min,running mean)		0.0 V
HV1	0.0 V	0.00 S
HV2	0.0 V	0.00 S
HV3	0.0 V	0.00 S
LV1	0.0 V	0.00 S
LV2	0.0 V	0.00 S
LV3	0.0 V	0.0 V

Voltage | Frequency

Click the 'IP' sub-setting on the 'Grid Setup' page to enter this page.
OverVoltage U(10min,running mean): The average value of the grid voltage over 10 minutes must not exceed this set value. If exceeded, the inverter will disconnect from the grid for protection.
HV1: Level 1 Overvoltage Point and Trip Time
HV2: Level 2 Overvoltage Point and Trip Time
HV3: Level 3 Overvoltage Point
LV1: Level 1 Undervoltage Point and Trip Time
LV2: Level 2 Undervoltage Point and Trip Time
LV3: Level 3 Undervoltage Point

Grid | Ip

HF1	0.00 Hz	0.00 S	LF1	0.00 Hz	0.00 S
HF2	0.00 Hz	0.00 S	LF2	0.00 Hz	0.00 S
HF3	0.00 Hz		LF3	0.00 Hz	

Voltage | Frequency

HF1: Level 1 Overfrequency Point and Trip Time
HF2: Level 2 Overfrequency Point and Trip Time
HF3: Level 3 Overfrequency Point
LF1: Level 1 Underfrequency Point and Trip Time
LF2: Level 2 Underfrequency Point and Trip Time
LF3: Level 3 Underfrequency Point

Grid | F(W)

P(Hf) P(Lf) Pn/Pmax

Droop F: 0%Pmax/Hz

Start Frequency F	0.00 Hz	Start Delay F	0.00 s
Stop Frequency F	0.00 Hz	Stop Delay F	0.00 s

Over Frequency | Under Frequency

Click the 'F(W)' sub-setting on the 'Grid Setup' page to enter this page.
P(Hf): When the grid frequency is high, the inverter reduces its active power output to decrease the excess energy in the grid system, helping to restore grid frequency stability.
P(Lf): When the grid frequency is low, the inverter will increase its active power output to help compensate for the power deficit of the grid system, thereby stabilizing the grid frequency.
Pn/Pmax: When enabled, the rated output power of the inverter is used as the reference value for Droop F. When disabled, the maximum output power of the inverter is used as the reference value for Droop F.
Droop F: P(Hf) Droop Rate. When pn/Pmax is enabled, the unit is Pn/Hz; When Pn/Pmax is disabled, the unit is Pmax/Hz.
Start Frequency F: P(Hf) Start Frequency.
Start Delay: P(Hf) mechanism start-up delay time.
Stop Frequency F: P(Hf) Stop Frequency.
Stop Delay: P(Hf) mechanism stop delay time.

Grid | F(W)

P(Hf) P(Lf) Pn/Pmax

Droop F: 0%Pn/Hz

Start Frequency F	0.00 Hz	Start Delay F	0.00 s
Stop Frequency F	0.00 Hz	Stop Delay F	0.00 s

Over Frequency | Under Frequency

Droop F: P(Lf) Droop Rate. When Pn/Pmax is enabled, the unit is Pn/Hz; When Pn/Pmax is disabled, the unit is Pmax/Hz.
Start Frequency F: P(Lf) Start Frequency.
Start Delay: P(Lf) mechanism start-up delay time.
Stop Frequency F: P(Lf) Stop Frequency.
Stop Delay: P(Lf) mechanism stop delay time.

Grid | v(W) v(Q)

Mincosphi 1.000 R.T(3Tau) 10.0s

P(U)

V1	109.0 %Un	P1	100 %
V2	111.0 %Un	P2	80 %
V3	113.0 %Un	P3	60 %
V4	115.0 %Un	P4	0 %

v(W) | v(Q)

Click the 'v(W) v(Q)' sub-setting on the 'Grid Setup' page to enter this page.
Mincosphi: Keep the default values under the current Grid code, no modification is needed.
P(U): Voltage-dependent Active Power Control. Adjust active power output automatically based on the grid connection point voltage, the higher the voltage, the lower the output.
R.T(3Tau): Dynamic response time of P(U) voltage control.
V1: Grid voltage level 1
P1: Upper limit of active power output level 1
V2: Grid voltage level 2
P2: Upper limit of active power output level 2
V3: Grid voltage level 3
P3: Upper limit of active power output level 3
V4: Grid voltage level 4
P4: Upper limit of active power output level 4

Grid | V(W) V(Q)

Mincosphi 0.000

Q(U) R.T(3Tau) 0.0s

Lock-in/Pn V1 0.0 %Un V2 0.0 %Un
0% V3 0.0 %Un V4 0.0 %Un

Lock-out/Pn Q1 0% Q2 0%
0% Q3 0% Q4 0%

V(W) | V(Q)

Q(U): The inverter can automatically adjust its reactive power output based on real-time grid voltage variations to stabilize the voltage at the point of common coupling (PCC). It absorbs inductive reactive power when the grid voltage is too high, and delivers inductive reactive power when the grid voltage is too low.

R.T(3Tau): Dynamic response time of Q(U) voltage control.

Lock-in/Pn: When the active power output by the inverter is below this set threshold, the Q(U) control mechanism will not be effective.

Lock-out/Pn: When the active power output by the inverter reaches this set threshold, the Q(U) control mechanism begins to take effect.

V1: Grid Voltage point 1

V2: Grid Voltage point 2

V3: Grid Voltage point 3

V4: Grid Voltage point 4

Q1: Reactive power output point 1

Q2: Reactive power output point 2

Q3: Reactive power output point 3

Q4: Reactive power output point 4

Grid | P(Q) P(PF)

Fixed Q 0.0% R.T(3tau) 0.0s P(Q)

P1 0% Q1 0%
P2 0% Q2 0%
P3 0% Q3 0%
P4 0% Q4 0%

P(Q) | P(PF)

Click the 'P(Q) P(PF)' sub-setting on the 'Grid Setup' page to enter this page.

P(Q): The inverter automatically outputs or absorbs reactive power according to the preset ratio based on the current active power output.

Fixed Q: The inverter will output or absorb reactive power at a fixed percentage as set.

R.T(3Tau): Dynamic Response Time of P(Q) Active-Reactive Power Control.

P1: Active power output point 1

Q1: Reactive power output point 1

P2: Active power output point 2

Q2: Reactive power output point 2

P3: Active power output point 3

Q3: Reactive power output point 3

P4: Active power output point 4

Q4: Reactive power output point 4

Grid | P(Q) P(PF)

Fixed Q 0.0% R.T(3tau) 0.0s P(PF)

Lock-in/Pn P1 0% P2 0%
0.0% P3 0% P4 0%

Lock-out/Pn PF1 0.000 PF2 0.000
0.0% PF3 0.000 PF4 0.000

P(Q) | P(PF)

P(PF): Dynamically adjust the inverter's power factor by controlling the output ratio of active and reactive power, based on the demand for active power.

P1/P2/P3/P4: Active power output point 1/2/3/4

PF1/PF2/PF3/PF4: PF1 means that when the inverter's active power output reaches the set value P1, its power factor will be maintained at this configured value; points 2, 3, and 4 follow accordingly.

Lock-in/Pn: When the ratio of the inverter's active power output to its rated power is below this set value, the P(PF) control mechanism will become inactive.

Lock-out/Pn: When the ratio of the inverter's active power output to its rated power reaches this set value, the P(PF) control mechanism will be activated.

Grid | LVRT

LVRT HVRT Zero | enable

HV3 0% HV3_T 0.00s
HV2 0% HV2_T 0.00s
HV1 0% HV1_T 0.00s
LV1 0% LV1_T 0.00s
LV2 0% LV2_T 0.00s

Click the 'H/LVRT' sub-setting on the 'Grid Setup' page to enter this page.

LVRT/HVRT: When the voltage of the power grid reaches the set HV or LV, the relay at the inverter grid port will remain closed for the set time to maintain stable grid connection without tripping.

Zero|enable: When the grid voltage drops abruptly to near 0V due to faults such as short circuits or lightning strikes, the inverter will remain grid-connected and continue operating without disconnecting or tripping within a specified time, and quickly resume normal power output after voltage recovery.

HV 3/2/1: Grid overvoltage level 3/2/1

HV 3/2/1_T: The Level 3/2/1 hold time corresponding to the level 3/2/1 Grid overvoltage threshold

LV 1/2: Grid undervoltage level 1/2

LV 1/2_T: The Level 1/2 hold time corresponding to the level 1/2 Grid undervoltage threshold

5.7 Battery Setup Menu

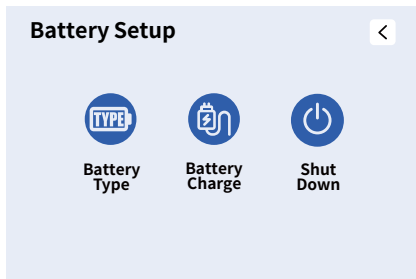

Click the 'Battery Setup' item on the 'Setting' page to enter this 'Battery Setup' page, this page contains 3 sub-settings.

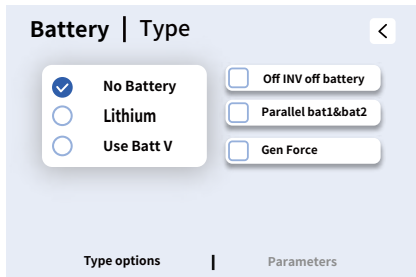

Click the 'Battery Type' sub-setting on the 'Battery Setup' page to enter this page.

No Battery: Check this option if no battery is connected to the system.

Lithium: When using batteries from the 'Approved Battery List' that can communicate with the inverter, check this option.

Use BattV: When using a lithium-ion battery that cannot communicate with the inverter, check this option.

Off INV off battery: When the inverter receives a remote shutdown command, the battery connected to this inverter will also be turned off.

Parallel bat1&bat2: When using the inverter's two battery power terminals and the BMS1 communication port to connect only one battery set (which can be multiple clusters connected in parallel), this function must be enabled.

Gen Force: Manually activate the 'G-Start' dry contact once to remotely start the connected generator.

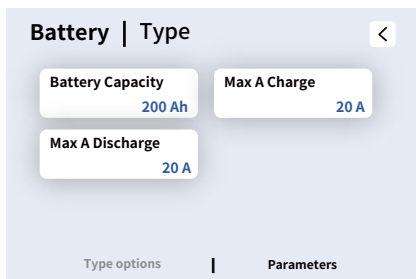

Battery Capacity: Reserved, currently unused, no need to set up.

Max A Charge: The upper limit of battery charging current limited by this hybrid inverter, including DC-DC charging and AC-DC charging

Max A Discharge: The upper limit of battery discharging current limited by this hybrid inverter.

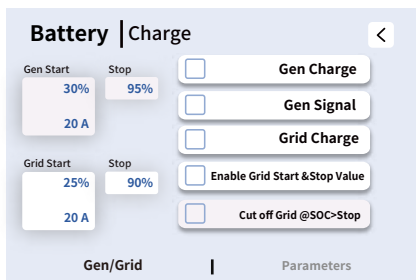

Click the 'Battery Charge' sub-setting on the 'Battery Setup' page to enter this page.

Gen Start: The SOC threshold for triggering the closure of the G-start dry contact. When the battery SOC drops below this set value and the Gen signal is enabled, the G-start dry contact will close to remotely start the generator.

A(@Gen Start): The maximum battery charging current limit by the inverter when only using AC power input from the GEN port to charge the battery.

Stop(@Gen Start): Only effective when the User Timer function is disabled, this setting controls the disconnection of the G-Start dry contact. When the battery SOC rises above this set value, the G-Start dry contact is triggered to open, remotely shutting down the generator. The generator icon on the inverter's LCD will disappear, and if the generator is connected to the hybrid inverter's GEN port, the main relays at the GEN port will also disconnect simultaneously. This set value is constrained to be no less than the "Gen Start" set value + 5%.

Grid Start: When the generator is connected to the inverter's Grid port and is already running, this setting controls the closing of the main relays at the inverter's Grid port once the battery SOC drops below this set value. The Grid Start set value must be less than the Gen Start set value. The Grid Start set value must be less than the Gen Start set value.

A(@Grid Start): The maximum battery charging current limit by the inverter when only using AC power input from the Grid port to charge the battery.

Stop(@Grid Start): This setting is effective only when the generator is connected to the inverter's Grid port and the User Timer function is disabled. When the battery SOC rises to this set value, it triggers the disconnection of the main relays at the inverter's grid port. This set value is constrained to be no less than the "Grid Start" set value + 5%, and less than the Stop(@Gen Start) set value.

Gen Charge: Whether to allow AC power input from the GEN port to charge the battery. When the User Timer is enabled, this can be controlled separately for different time periods.

Gen Signal: Whether to use the G-Start dry contact to remotely control the start and stop of the generator.
Grid Charge: Whether to allow AC power input from the Grid port to charge the battery. When the User Timer is enabled, this can be controlled separately for different time periods.
Enable Grid Start&Stop Value: Whether to use Grid Start and Stop (@Grid Start) to control the status of the Grid port's main relays, when the generator is connected to the inverter's Grid port and the User Timer function is disabled.
Cut off Grid@SOC>Stop: When the generator is connected to the inverter's Grid port, the User Timer function is disabled, and the Enable Grid Start & Stop Value function is enabled, enabling this feature will cause the main relay at the inverter's Grid port to disconnect when the battery SOC rises above this set value.

Battery | Charge <

Gen Max Run Time 24.0 h

Gen Down Time 0.0 h

Gen/Grid | Parameters

Gen Max Run Time: It indicates the longest time Generator can run in one day, when time is up, the Generator will be turned off. 24H means that it does not shut down all the time.

Gen Down Time: It indicates the rest time of the generator before the inverter start it again.

Battery | Shut Down <

Lithium Mode 00 Shut Down 10%

Low Battery 20% Restart 50%

Click the 'Shut Down' sub-setting on the 'Battery Setup' page to enter this page.

Lithium Mode: Please refer to the officially released battery compatibility list to find the communication protocol number between the current battery model and the inverter.

Shutdown : Be valid in Off-grid mode, battery can discharge to this voltage, then the DC/AC inverter module of this inverter will be shut down and the solar power can only be used to charge the battery.

Low Batt: In on-grid mode, when the 'Grid charge' has been checked and the set target battery SOC on 'Use Timer' page isn't less than the set value of "Low Batt", the battery SOC will remain not less than the set value of "Low Batt". In off-grid mode, when battery SOC drops to this set value, the beeper will sound.

Restart : Be valid in Off-grid mode, after the DC/AC inverter module of this inverter is shut down, the PV power can only be used to charge the battery. After the battery SOC has resumed to this "Restart" value, the DC/AC inverter module will restart to output AC power.

Battery | Shut Down <

Float V 552.0 V Shut Down 160.0 V

Low Battery 170.0 V Restart 180.0 V

When the "Use Batt V" mode is selected, the content on the "Battery/Shut Down" page is shown in the figure on the left.

Float V: Floating charge voltage of the battery.

Shutdown : Be valid in Off-grid mode, battery can discharge to this voltage, then the DC/AC inverter module of this inverter will be shut down and the solar power can only be used to charge the battery.

Low Batt: In on-grid mode, when the 'Grid charge' has been checked and the set target battery voltage on 'Use Timer' page isn't less than the set value of "Low Batt", the battery voltage will remain not less than the set value of "Low Batt". In off-grid mode, when battery Voltage drops to this set value, the beeper will sound.

Restart : Be valid in Off-grid mode, after the DC/AC inverter module of this inverter is shut down, the PV power can only be used to charge the battery. After the battery voltage has resumed to this "Restart" value, the DC/AC inverter module will restart to output AC power.

5.8 Quick Control Menu

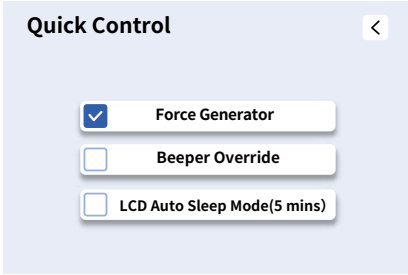

Click the 'Quick Control' item on the 'Setting' page to enter this page, this page contains 3 parameters.
Force generator: Manually activate the 'G-Start' dry contact once to remotely start the connected generator.
Beeper Override: Silence the beeper.
LCD Auto Sleep Mode(5 mins): When enabled, the LCD will automatically enter sleep mode after 5 minutes of inactivity.

5.9 Info and Fault Code Menu

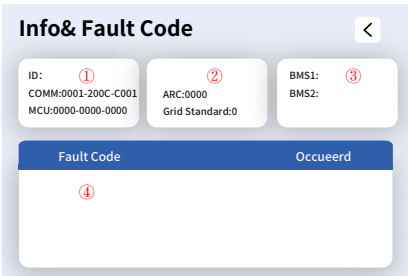

Click the 'Fault Code' item on the 'Setting' page to enter this page, this page contains 4 zones.
Zone 1 displays the inverter's serial number, the firmware version of the COMM board, and the firmware version of the MCU board.
Zone 2 displays the firmware version of the ARC board and the configured Grid code.
Zone 3 displays the firmware versions of the two battery sets (if installed).
Zone 4 displays the information of fault.

5.10 Gen and Aux Load Menu

Gen & Aux Load

Generator Input

Smart Load Output

ON-Grid Inv

Gen Peak Shaving

GEN Connect to Grid input

Rated Power **0 W**

AC Couple On Grid Side

AC Couple on Load Side

Click the 'Aux load' item on the 'Setting' page to enter this 'Gen & Aux Load' page, this page contains 3 sub-settings.

The GEN port is a multifunctional port, but only one of the following three functions can be selected when using this port.

Generator Input: Used as an AC input to connect external AC generator source.

Gen Peak Shaving Power: Limit the maximum output power of the generator to the set 'Rated power' below, the rest of power consumption will be provided by inverter to ensure that the generator will not overload.

GEN Connect to Grid input: Connect the AC generator source to the grid input port of this inverter.

Rated Power: The expected maximum output power of the AC generator, which usually does not exceed 80% of the generator's actual rated capacity.

AC Couple On Grid Side: Connect other AC power sources (such as on-grid inverters) at the Grid port side of this hybrid inverter.

AC Couple On Load Side: Connect other AC power sources (such as on-grid inverters) at the Load port side of this hybrid inverter.

Gen & Aux Load

Generator Input

Smart Load Output

ON-Grid Inv

GEN connect to Grid input

OFF Batt **450.0 V**

ON Batt **550.0 V**

On Grid always on

Smart Load Output: Use the GEN port as an AC output port. The inverter can control the power supply to the load connected to this port by controlling the state of the main relays of the GEN port.

OFF Batt: When the battery's SOC/voltage drops to this set value, the inverter will disconnect the main relays of the GEN port and stop supplying power to the smart load.

ON Batt: When the battery's SOC/voltage rises to this set value, the inverter will engage the main relays of the GEN port and start supplying power to the smart load.

On grid always on: When enabled, if the hybrid inverter operates in grid-connected mode, its main relays of the GEN port will remain engaged, allowing the inverter to continuously supply power to the smart load.

Gen & Aux Load

Generator Input

Smart Load Output

ON-Grid Inv

GEN connect to Grid input

OFF Batt **550.0 V**

ON Batt **450.0 V**

AC Couple Frz High **0.00Hz**

MI export to Grid cutoff

On-grid INV Input: Use the GEN port as an AC input port, through which the output power from other grid-following AC sources (such as on-grid inverters) can be fed into the hybrid inverter.

OFF Batt: When the hybrid inverter operates in off-grid mode, once the SOC/voltage of the connected battery rises to this set value, the hybrid inverter will disconnect the main relay of its GEN port, thereby cutting off the power supply from the external AC source (such as on-grid inverters) to prevent the battery from being overcharged.

ON Batt: When the hybrid inverter operates in off-grid mode, once the SOC/voltage of the connected battery drops to this set value, the hybrid inverter will engage the main relays of its GEN port, thereby feeding the power from the external AC source (such as on-grid inverters) into the hybrid inverter to charge the battery.

AC Couple Frz High: When the hybrid inverter operates in off-grid mode and an on-grid inverter is AC-coupled to its GEN or Load port, once the battery SOC/voltage rises to the 'OFF Batt' set value, the hybrid inverter will increase its AC output frequency to a predefined trip threshold (e.g., 52 Hz), causing the grid-following inverter to disconnect automatically.

MI export to Grid cutoff: Disconnect the main relays of the GEN port to prevent the excess part of the AC power output by the on-grid inverter from being fed into the grid.

5.11 System Mode Menu

System Mode

System Limited

System TOU

System Mode

Click the 'System Mode' item on the 'Setting' page to enter this 'System Mode' page, this page contains 3 sub-settings.

System | Limited

Selling First

Zero Export to load

Zero Export to CT

Batt First

Load First

Zero Export Power 0W

Max Solar Power 0W

Max Sell Power 0W

Grid Peak Shaving

0W

Selling First: This Mode allows hybrid inverter to sell back any excess power produced by the solar panels to the grid. If "Use Timer" is enabled, the battery energy also can be sold into grid.

Photovoltaic power is prioritized for load consumption or battery charging (the specific priority depends on whether Load First or Batt First is set, and whether grid charging is enabled), and only the surplus power can be exported to the grid.

Power source priority for the load is as follows:

1. Solar power (including AC coupled on-grid inverters)
2. Batteries (when the actual battery SOC is higher than the target SOC).
3. Grid or generator.

Max Solar Power: the maximum DC input power allowed.

Zero Export to load: Hybrid inverter will only provide power to the backup load connected. The hybrid inverter will neither provide power to the home load nor sell power to grid, if the "solar sell" behind is not enabled. The built-in CT will detect power flowing back to the grid and will reduce the power of the inverter only to supply the backup load and charge the battery. **Load consumption=Backup load.**

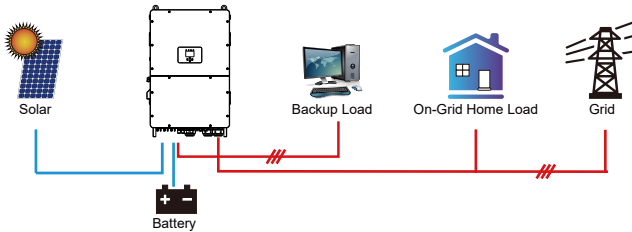

Zero Export to CT : Hybrid inverter will not only provide power to the backup load connected but also give power to the home load connected. If PV power and battery power is insufficient, it will take grid energy as supplement. The hybrid inverter will not sell power to grid, if the "solar sell" behind is not enabled. In this mode, external CTs or smart meter must be installed. For the installation method of CTs or smart meter, please refer to the section 3.7 . The external CTs or smart meter will detect power flowing back to the grid and will reduce the power of the inverter only to supply the backup load, home load and charge the battery. **Load consumption=Backup load+home load.**

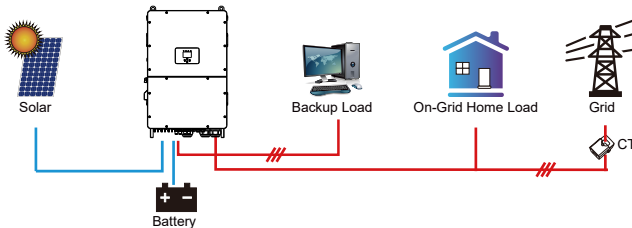

Max. sell power: Maximum power allowed to flow to grid.

Zero-export Power: This parameter will ensure the zero-export by taking from the grid some small amount of power that has been set with this value. It is recommended to set it as 20-100W to ensure the hybrid inverter won't feed power to grid.

Batt First: PV power is firstly used to charge the battery, and the excess power will be used to power the load. If the PV power cannot meet the battery charging power demand, the grid can supplement power to charge the battery while bearing the load power.

Load First: PV power is firstly used to power the load, and the excess power will be used to charge the battery. If the photovoltaic power cannot solely meet the load's power demand, the shortfall will be supplemented by the battery and the grid.

Grid Peak Shaving: when it is enabled, grid power will be limited within the set value. If the grid peak shaving power +PV power+ battery power cannot meet the power consumption of the load after peak shaving, the grid peak shaving will be invalid, and the power taken from the grid can exceed this set value.

System | Limited

Selling First

Zero Export to load

Zero Export to CT

Solar Sell

Batt First

Load First

Zero Export Power 0W

Max Solar Power 0W

Max Sell Power 0W

Grid Peak Shaving 0W

Solar sell: It's the sub-setting of 'Zero export to load' and 'Zero export to CT' mode. When it is active, the energy generated by the PV array will first power the loads and charge the battery, and then the excess PV power can be sold to the grid.

System | TOU

Use Timer

Time	Power	Batt	Gen	Grid	Gen	Sell
00:05	125000W	80%	0%	<input checked="" type="checkbox"/>	<input checked="" type="checkbox"/>	<input type="checkbox"/>
05:00	125000W	40%	0%	<input checked="" type="checkbox"/>	<input checked="" type="checkbox"/>	<input type="checkbox"/>
08:00	125000W	40%	0%	<input type="checkbox"/>	<input checked="" type="checkbox"/>	<input type="checkbox"/>
10:00	125000W	80%	0%	<input type="checkbox"/>	<input checked="" type="checkbox"/>	<input type="checkbox"/>
15:00	125000W	40%	0%	<input type="checkbox"/>	<input checked="" type="checkbox"/>	<input type="checkbox"/>
18:00	125000W	35%	0%	<input type="checkbox"/>	<input checked="" type="checkbox"/>	<input type="checkbox"/>

Use Timer: it is used to program when to use grid or generator to charge the battery, and when to discharge the battery to power the load. Only when 'Use Timer' is checked can the parameters below be set.

Note: Only when the hybrid inverter operates in selling first mode and the 'Use Timer' has been enabled, the battery power can be sold to the grid.

Time: The start time of the current period and the end time of the previous period.

Note: 1: For more flexible and controllable use of batteries, it is recommended to enable the "Use Timer" function. When the inverter is operating in on-grid mode and "Use Timer" is not enabled, the inverter can charge normally, but only discharge to provide the inverter's self-consumption power, without discharging to power the loads.

2: Only the 6th time period is allowed to cross midnight.

Power: The maximum allowed discharge power of the battery is only valid in the "Selling First" mode.

Batt: The target value of battery voltage or SOC during the current time period. If the actual SOC or voltage of the battery is lower than the target value, the battery needs to be charged. If there is an energy source like solar power or grid, the battery will be charged; if the actual SOC or voltage of the battery is higher than the target value, the battery can discharge, and when the solar power is not enough to power the load or the "Selling First" is enabled, the battery will discharge.

Assuming that at the end of the previous time period, the actual battery SOC/voltage reaches or approaches the target value of the previous time period.

For example

During 00:00-05:00,
if battery SOC is lower than 80%, it will use grid to charge the battery until battery SOC reaches 80%.

During 05:00-08:00,
if battery SOC is higher than 40%, hybrid inverter will discharge the battery until the SOC reaches 40%. At the same time, if battery SOC is lower than 40%, then grid will charge the battery SOC to 40%.

During 08:00-10:00,
if battery SOC is higher than 40%, hybrid inverter will discharge the battery until the SOC reaches 40%.

During 10:00-15:00,
If battery SOC is lower than 80%, hybrid inverter will charge the battery until the SOC reaches 80%. If the PV power is sufficient, the battery can be charged to 100%.

During 15:00-18:00,
when battery SOC is higher than 40%, hybrid inverter will discharge the battery until the SOC reaches 40%.

During 18:00-00:00,
when battery SOC is higher than 35%, hybrid inverter will discharge the battery until the SOC reaches 35%.

GEN(%): When the "Use Timer" function is enabled, the G-S dry contact will open when the battery SOC rises to (GEN% - 1%). Consequently, the generator icon on the inverter's LCD will disappear, and the inverter will disconnect the main relays between itself and the generator. The set value for "Batt" (the target value for battery SOC/voltage) should be less than (GEN% - 1%).

Grid: It allows AC power to be drawn from the Grid port side for battery charging.

Gen: It allows AC power to be drawn from the Gen port side for battery charging.

Sell: When enabled, during the current time period, the work mode will be "Selling first", which the excess photovoltaic power and battery discharging power can be sold to the grid.

System | Mode

Mon Tue Wed Thu Fri Sat Sun

Soft export control set

P 0.0%Pmax

Hard export control set

P 0.0%Pmax

Mon/Tue/Wed/Thu/Fri/Sat/Sun: It allows users to choose which day to execute the setting of "Use Timer".

Soft export control set: The export power is limited by software, such that the upper limit of export power as a percentage of the maximum AC output active power does not exceed this set value.

Hard export control set: The export power is limited by hardware, such that the upper limit of export power as a percentage of the maximum AC output active power does not exceed this set value.

5.12 Network Menu

Network <

Manual ▾

IP Address 192.168.18.19

Subnet Mask 255.255.255.0

Gateway 192.168.18.1

Network <

DHCP ▾

IP Address 192.168.18.19

Subnet Mask 255.255.255.0

Gateway 192.168.18.1

Click the 'Network' item on the 'Setting' page to enter this page.
Manual: Manually configure a static IP address, subnet mask, and gateway for the hybrid inverter based on the local network router settings.

DHCP: The LAN router automatically assigns an IP address, subnet mask, and gateway to the hybrid inverter according to its configuration.

Note: This function is used for communication with the upper computer monitoring software based on the Modbus TCP protocol.

5.13 Advanced Menu

Advance <

 **Multi-Inverter**

 **P-Shave**

 **Wind Turbine**

 **CT Check**

Click the 'Advance' item on the 'Setting' page to enter this page, this page contains 4 sub-settings.

Advance | Multi-Inverter <

Parallel **Baud Rate 115200**

Slave **01** ⓘ

Ex_Meter for CT

Meter Select **No Meter**

Grid Tie Meter2

MPPT_Scan

Parallel: Enable this function when several same model hybrid inverters are connecting in parallel.

Set this inverter as the master inverter to serve as the control hub of the parallel system, responsible for coordinating the synchronous operation of all inverters in the system and ensuring the stability and efficiency of energy flow, mode switching, and load distribution.

Slave: Set this inverter as a slave inverter to receive control commands from the master inverter and maintain synchronization with it.

①: The Modbus address of each inverter, should be different.

Baud Rate: The rate at which inverter transmits data.

Note: In a system with multiple inverters operating in parallel, if one inverter stops output due to a fault, it typically triggers all other inverters in the parallel system to report faults and cease output as well.

Ex_Meter For CT: When the CT feeder length is insufficient or the CT range is inadequate, a meter can be used as an alternative. The meter must be of a matched model and procured through official channels to ensure compatibility.

Grid Tie Meter2: When there are one or more grid-tied inverters AC coupled on the grid or load port side of the hybrid inverter, and external meter is installed for this/these grid-tied inverters, it is necessary to enable this function to upload the data of the external meter to the hybrid inverter to ensure that the power consumption data of the load is correct.

MPPT Scan: After enabling this function, MPPT will perform I-V curve scanning every 5 minutes to find the maximum power point again and eliminate MPPT failure caused by shadows.

Advance | P-Shave <

Solar Arc Fault ON Backup Delay
 Clear Arc_Fault 0 ms

System Selfcheck CT Ratio
 DRM 0:1

Neutral to earth bonding Island Enable
 Asymmetric phase feeding CEI Report

Solar Arc Fault ON(Optional): This function is optional. Some models do not have this function, and the specific details are subject to the hardware version of the inverter received. After enabling this function, the inverter will detect whether there is an arcing fault on the PV side. If arcing occurs, the inverter will report a fault and stop outputting power.

Clear Arc_Fault(Optional): After the arc fault on the PV side is eliminated, enabling this function can eliminate the arc fault alarm of the inverter and restore normal operation of the inverter.

System selfcheck: Disable. this is only for factory.

DRM: Demand response mode, receive external commands for active power scheduling and reactive power scheduling.

Backup Delay: When the grid cuts off, the inverter will output power after the set time.
 For example, backup delay: 600s. the inverter will give output power after 600s when the grid cuts off.

Note: for some old FW version, this function is not available.

CT Ratio: The ratio of the rated primary current to the rated secondary current of the current transformer multiplied by 100.

Neutral to earth bonding: When the "Neutral to Earth Bonding" function is enabled, and the inverter operates in off-grid mode, the internal relay between neutral (load port N) and protective earth (PE) will close, bonding the neutral line to the inverter ground.

Note: If this function is enabled, the inverter shell must be reliably grounded. Failure to do so may result in an electric shock hazard upon contact with the inverter shell.

The parameter name has been changed, and the corresponding parameter name in the old version firmware is "Signal island mode".

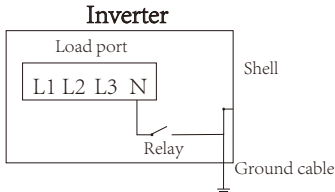

Asymmetric phase feeding: When the loads connected to the Load port have an unbalanced distribution on the three phases and the inverter is working in on-grid mode, enabling this function will ensure an equal power absorption from the three phases of grid.

CEI Report: Invalid. Only for inverters not exceed 11.08kW, output a self-test report according to Italian CEI 0-21 standards.

Island Enable: Enable islanding protection mechanism. When checked, the inverter will activate the islanding protection function. Upon grid power failure, the inverter can quickly detect the loss of grid and automatically disconnect its internal relays, thereby isolating itself from the grid to prevent the formation of an "islanding effect".

Advance | Wind Turbine <

V1	V7
V2	V8
V3	V9
V4	V10
V5	V11
V6	V12

DC | V/I

This is for Wind Turbine

The graph shows a curve of current (I/A) versus voltage (U/V). The y-axis has a mark at 16.5 and the x-axis has a mark at 310. The curve starts near the origin and rises steeply.

V1-V12: Use 12 points to fit the U/I curve output by the wind turbine controller.
 Maximum input voltage is 850V and maximum input current is 36A.

DC1/2/3/4/5/6/7/8/9/10/11/12 for Wind Turbine:
 When checked, it indicates that this MPPT channel is used to connect to the wind turbine controller.

Advance | Wind Turbine <

<input type="checkbox"/> DC1 for Wind Turbine	<input type="checkbox"/> DC6 for Wind Turbine
<input type="checkbox"/> DC2 for Wind Turbine	<input type="checkbox"/> DC7 for Wind Turbine
<input type="checkbox"/> DC3 for Wind Turbine	<input type="checkbox"/> DC8 for Wind Turbine
<input type="checkbox"/> DC4 for Wind Turbine	<input type="checkbox"/> DC9 for Wind Turbine
<input type="checkbox"/> DC5 for Wind Turbine	<input type="checkbox"/> DC10 for Wind Turbine

DC | V/I

Advance | CT Check

CT Check Start

	CT Phase	Polarity	Check Result Information
A Phase -	A	+	
B Phase -	B	+	
C Phase -	C	+	

CT Check: Inverter will perform self check on external CT and return the test results.
Start: Starting CT self-test.
CT phase: The actual CT in the current phase occupies which phase's corresponding CT terminals.
Polarity: Whether the secondary side feeder polarity of the CT on the CT terminal is reversed — "++" indicates correct polarity, "-+" indicates reversed polarity.

6. Mode

Mode I: Basic

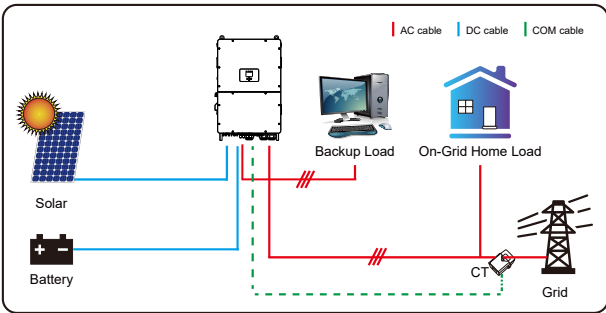

Mode II: With Generator

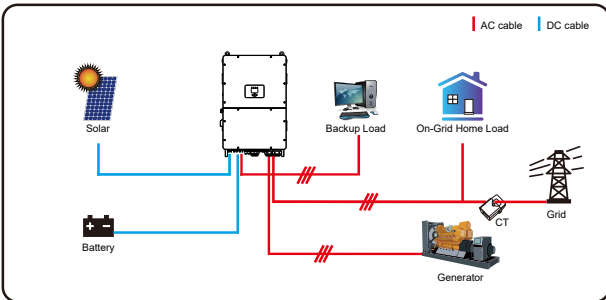

Note: When using the GEN port as the "generator input" port, the relays on the grid port and GEN port of the inverter will not be closed simultaneously. The relays on the GEN port will only be closed when the inverter is running in off-grid mode.

Mode III: With Smart-Load

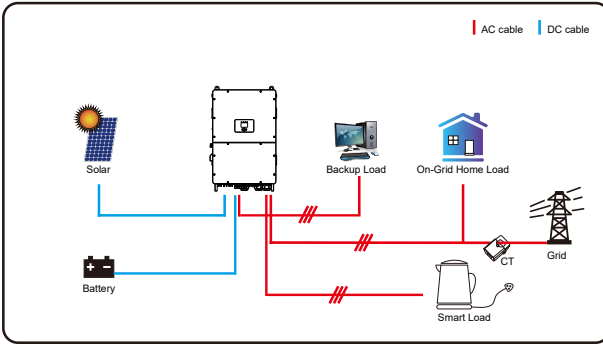

Mode IV: AC Couple

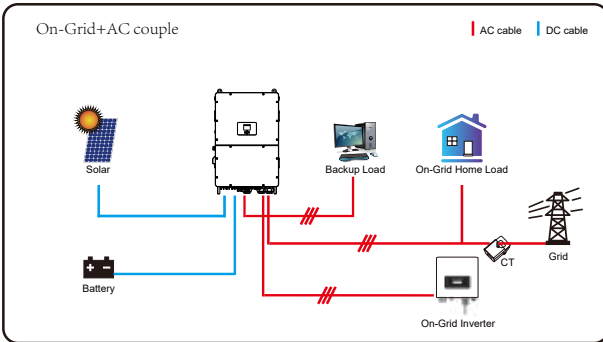

The 1st priority power of the system is always the PV power, then 2nd and 3rd priority power will be the battery bank or grid according to the settings. The last power backup will be the Generator if it is available.

7. Warranty

As to Warranty terms, please refer to 《General Warranty Agreement - DEYE》.

Under the guidance of our company, customers return our products so that our company can provide service of maintenance or replacement of products of the same value. Customers need to pay the necessary freight and other related costs. Any replacement or repair of the product will cover the remaining warranty period of the product. If any part of the product or product is replaced by the company itself during the warranty period, all rights and interests of the replacement product or component belong to the company.

Factory warranty does not include damage due to the following reasons:

-
- Damage during transportation of equipment;
 - Damage caused by incorrect installation or commissioning;
 - Damage caused by failure to comply with operation instructions, installation instructions or maintenance instructions;
 - Damage caused by attempts to modify, alter or repair products;
 - Damage caused by incorrect use or operation;
 - Damage caused by insufficient ventilation of equipment;
 - Damage caused by failure to comply with applicable safety standards or regulations;
 - Damage caused by natural disasters or force majeure (e.g. floods, lightning, overvoltage, storms, fires, etc.)

In addition, normal wear or any other failure will not affect the basic operation of the product. Any external scratches, stains or natural mechanical wear does not represent a defect in the product.

8. Troubleshooting

Perform troubleshooting according to the solutions in the table below. Contact the after-sales service if these methods do not work.

Collect the information below before contacting the after-sales service, so that the problems can be solved quickly.

- Inverter information like serial number, firmware version, installation date, fault time, fault frequency, etc.
- Installation environment, including weather conditions, whether the PV modules are sheltered or shadowed, etc. It is recommended to provide some photos and videos to assist in analyzing the problem.
- Utility grid situation.

Error code	Description	Solutions
W01	Reserved	
W02	FAN_IN_Warn	<ol style="list-style-type: none"> 1. Check the operating status of the fan. 2. If the fan is running abnormally, open the cover of the inverter to check the connection of the fan.
W03	Grid_phase_warn	<ol style="list-style-type: none"> 1. Check the phase sequence connection of the power grid. 2. Try to change the grid type, 0, 240/120. 3. If there is still no solution to check the wiring at the grid end.
W04	Meter_offline_warn	<p>Meter communication failure</p> <p>Check whether the meter has successful communication and whether the wiring is normal.</p>
W05	CT_WRONG_direction_warn	Check whether the arrow on CT's case point to the inverter or not , and check if the installation location of CTs are correct.
W06	CT_Notconnect_warn	Check whether the wires of CTs are connected correctly or not.
W07	FAN_OUT1_Warn	Check whether the FAN are connected correctly and operating normally.
W08	FAN_OUT2_Warn	Check whether the FAN are connected correctly and operating normally.
W09	FAN_OUT3_Warn	Check whether the FAN are connected correctly and operating normally.
W10	VW_activate	<ol style="list-style-type: none"> 1. Measure whether the grid port voltage is too high. 2. Check whether the AC cable is too thin to carry current.
W31	Battery_comm_warn	<p>Abnormal battery communication</p> <ol style="list-style-type: none"> 1. Check whether the BMS connection is stable. 2. Check whether the BMS data is abnormal.
W32	Parallel_comm_warn	<p>Unstable parallel communication</p> <ol style="list-style-type: none"> 1. Check the connection of the parallel communication line. Please do not wind the parallel communication line with other cables. 2. Check whether the parallel dip switch is on.
F01	DC_Inversed_Failure	Check the PV input polarity.
F02	DC_Insulation_Failure	Check whether the PV is grounded, secondly, check whether the impedance of the PV to the ground is normal.
F03	GFDI_Failure	<ol style="list-style-type: none"> 1. Check whether the PV modules are grounded. 2. Check whether the impedance of the PV to the ground is normal, whether there is leakage current.

Error code	Description	Solutions
F04	GFDI_Ground_Failure	Check whether the PV is grounded.
F05	EEPROM_Read_Failure	Restart the inverter 3 times and restore the factory settings.
F06	EEPROM_Write_Failure	Restart the inverter 3 times and restore the factory settings
F07	DCDC1_START_Failure	The BUS voltage can't be reached by PV or battery. 1. Switch off the DC switches and restart the inverter.
F08	DCDC2_START_Failure	The BUS voltage can't be reached by PV or battery. 1. Switch off the DC switches and restart the inverter.
F09	IGBT_Failure	Restart the inverter 3 times and restore the factory settings.
F10	AuxPowerBoard_Failure	1. First check whether the inverter switch is open. 2. Restart the inverter 3 times and restore the factory settings.
F11	AC_MainContactor_Failure	Restart the inverter 3 times and restore the factory settings.
F12	AC_SlaveContactor_Failure	Restart the inverter 3 times and restore the factory settings.
F13	Working_Mode_Change	1. When the grid type and frequency have changed it will report F13. 2. When the battery mode has been changed to "No battery" mode, it will report F13. 3. For some old FW version, it will report F13 when the system's work mode has been changed. 4. Generally, this error will disappear automatically. 5. If it remains the same, turn off DC and AC switches for one EEPROM_Write_Failure minute, then turn on the DC and AC switches.
F14	DC_OverCurr_Failure	Restart the inverter 3 times and restore the factory settings.
F15	AC_OverCurr_SW_Failure	AC side over current fault 1. Please check whether the backup load power and common load power are within the range. 2. Restart and check whether it is normal.
F16	GFCI_Failure	Leakage current fault 1. Check the PV side cable ground connection. 2. Restart the system 2-3 times.
F17	Tz_PV_OverCurr_Fault	1. Check the PV connection and whether the PV is unstable. 2. Restart the inverter 3 times.
F18	Tz_AC_OverCurr_Fault	AC side over current fault 1. Please check whether the backup load power and commonload power are within the range. 2. Restart and check whether it is normal.
F19	Tz_Integ_Fault	Restart the inverter 3 times and restore the factory settings.

Error code	Description	Solutions
F20	Tz_Dc_OverCurr_Fault	DC side over current fault 1. Check PV module connection and battery connection; 2. When in the off-grid mode, starting the inverter under a high power load may report F20. Please reduce the load power connected. 3. If it remains the same, turn off DC and AC switches for one minute, then turn on the DC and AC switches.
F21	Tz_HV_Overcurr_Fault	BUS over current 1. Check the PV input current and battery current setting. 2. Restart the system 2~3 times.
F22	Tz_EmergStop_Fault	Remotely shutdown It means the inverter is remotely controlled.
F23	Tz_GFCI_OC_Fault	Leakage current fault 1. Check PV side cable ground connection. 2. Restart the system 2~3 times.
F24	DC_Insulation_Fault	PV isolation resistance is too low 1. Check the connection of PV panels and inverter is firm and correct. 2. Check whether the PE cable of inverter is connected to ground.
F25	DC_Feedback_Fault	Restart the inverter 3 times and restore the factory settings.
F26	BusUnbalance_Fault	1. Please wait for a while and check whether it is normal. 2. When the load power of 3 phases has a big different, it will report the F26. 3. When there's DC leakage current, it will report F26. 4. Restart the system 2~3 times.
F27	DC_Insulation_Fault	Restart the inverter 3 times and restore the factory settings.
F28	DCIOver_M1_Fault	Restart the inverter 3 times and restore the factory settings.
F29	Parallel_Comm_Fault	1. When inverters are connected in parallel, check the parallel communication cable connection and hybrid inverter communication address setting. 2. During the parallel system startup period, inverters will report F29. But when all inverters are in ON status, it will disappear automatically.
F30	AC_MainContactor_Fault	Restart the inverter 3 times and restore the factory settings.
F31	AC_SlaveContactor_Fault	1. Check whether the grid orientation is correct, 2. Restart the inverter 3 times and restore the factory settings
F32	DCIOver_M2_Fault	Restart the inverter 3 times and restore the factory settings.
F33	AC_OverCurr_Fault	1. Check whether the grid current is too large. 2. Restart the inverter 3 times and restore the factory settings.
F34	AC_Overload_Fault	Check the backup load connection, make sure it is within the allowed power range.

Error code	Description	Solutions
F35	AC_NoUtility_Fault	Check the grid voltage and frequency, whether the connection of the power grid is normal.
F36	Reserved	
F37	Reserved	
F38	Reserved	
F39	INT_AC_OverCurr_Fault	Inverter AC overcurrent, restart the inverter.
F40	INT_DC_OverCurr_Fault	Inverter DC overcurrent, restart the inverter.
F41	Parallel_system_Stop	Check the hybrid inverter work status. If there is at least one hybrid inverter shutdown, all hybrid inverters will report F41 fault.
F42	Parallel_Version_Fault	1. Check whether the inverter version is consistent. 2. Please contact us to upgrade the software version.
F43	Reserved	
F44	Reserved	
F45	AC_UV_OverVolt_Fault	Grid voltage out of range 1. Check the voltage is in the range of specification or not. 2. Check whether AC cables are firmly and correctly connected.
F46	AC_UV_UnderVolt_Fault	Grid voltage out of range 1. Check the voltage is in the range of specification or not. 2. Check whether AC cables are firmly and correctly connected.
F47	AC_OverFreq_Fault	Grid frequency out of range 1. Check whether the frequency is in the range of the specification or not. 2. Check whether AC cables are firmly and correctly connected.
F48	AC_UnderFreq_Fault	Grid frequency out of range 1. Check whether the frequency is in the range of the specification or not. 2. Check whether AC cables are firmly and correctly connected.
F49	AC_U_GridCurr_DcHigh_Fault	Restart the inverter 3 times and restore the factory settings.
F50	AC_V_GridCurr_DcHigh_Fault	Restart the inverter 3 times and restore the factory settings.

Error code	Description	Solutions
F51	Battery_Temp_High_Fault	Check whether the temperature data of BMS is too high.
F52	DC_VoltHigh_Fault	BUS voltage is too high 1. Check whether battery voltage is too high. 2. Check the PV input voltage, make sure it is within the allowed range.
F53	DC_VoltLow_Fault	BUS voltage is too low 1. Check whether battery voltage is too low. 2. If the battery voltage is too low, use PV or grid to charge the battery.
F54	BAT2_VoltHigh_Fault	1. Check the battery 2 terminal voltage is high. 2. Restart the inverter 2 times and restore the factory settings.
F55	BAT1_VoltHigh_Fault	1. Check the battery 1 terminal voltage is high. 2. Restart the inverter 2 times and restore the factory settings.
F56	BAT1_VoltLow_Fault	1. Check the battery 1 terminal voltage is low. 2. Restart the inverter 2 times and restore the factory settings.
F57	BAT2_VoltLow_Fault	1. Check the battery 2 terminal voltage is low; 2. Restart the inverter 2 times and restore the factory settings.
F58	Battery_Comm_Lose	1. It means that the communication between the hybrid inverter and the battery BMS is disconnected when "BMS_Err-Stop" is active. 2. To avoid this error, disable "BMS_Err-Stop" item on the LCD.
F59	Reserved	
F60	GEN_FAULT	Check whether the voltage and frequency of the generator are normal, and then restart.
F61	INVERTER_Manual_OFF	Check whether the switch of the inverter is turned on, restart the inverter, and restore the factory settings.
F62	DRMs_Stop	Check the DRM function is active or not.
F63	ARC_Fault	1. ARC fault detection is only for US market. 2. Check PV module cable connection and clear the fault.
F64	Heatsink_HighTemp_Fault	Heat sink temperature is too high 1. Check whether the working environment temperature is too high. 2. Turn off the inverter for 10 minutes and restart.

Chart 8-1 Fault information

9. Datasheet

Model	SUN-100K-SG02HP3 -EU-GM8	SUN-100K-SG02HP3 -EU-GM10	SUN-125K-SG02HP3 -EU-GM10
Battery Input Data			
Battery Type	Lithium-ion		
Battery Voltage Range(V)*	160-1000		
Max. Charging Current(A)	100+100		
Max. Discharging Current(A)	100+100		
Charging Strategy for Li-ion Battery	Self-adaption to BMS		
Number of Battery Input	2		
PV String Input Data			
Max. PV access power(W)	200000	200000	250000
Max. PV Input Power(W)	160000	160000	200000
Max. PV Input Voltage (V)	1000		
Start-up Voltage(V)	180		
PV Input Voltage Range(V)*	180-1000		
MPPT Voltage Range(V)	150-850		
Full Load MPPT Voltage Range(V)	390-850	310-850	390-850
Rated PV Input Voltage (V)	650		
Max. Operating PV Input Current(A)	42+42+42+42+42+42+42	42+42+42+42+42+42+42+42	
Max. Input Short-Circuit Current(A)	63+63+63+63+63+63+63	63+63+63+63+63+63+63+63	
No. of MPP Trackers/No. of Strings MPP Tracker	8/2+2+2+2+2+2+2	10/2+2+2+2+2+2+2+2	
Max. Inverter Backfeed Current To the Array	0		
AC Input/Output Data			
Rated AC Input/Output Active Power(W)	100000	100000	125000
Max. AC Input/Output Apparent Power(VA)	110000	110000	135000
Peak Power (off-grid)(W)	1.5 time of rated power, 10 S		
Rated AC Input/Output Current(A)	151.6/145.0	151.6/145.0	189.4/181.2
Max. AC Input/Output Current(A)	166.7/159.5	166.7/159.5	204.6/195.7
Max. Continuous AC Passthrough (grid to load)(A)	250		
Max. Output Fault Current (A)	450		
Max. Output Overcurrent Protection (A)	550		
Rated Input/Output Voltage/Range(V)	220/380V, 230/400V 0.85Un-1.1Un		
Grid Connection Form	3L+N+PE		
Rated Input/Output Grid Frequency/Range	50Hz/45Hz-55Hz 60Hz/55Hz-65Hz		
Power Factor Adjustment Range	0.8 leading to 0.8 lagging		
Total Current Harmonic Distortion THDi	<3% (of nominal power)		
DC Injection Current	<0.5% In		
Efficiency			
Max. Efficiency	98.70%		
Euro Efficiency	98.10%		
MPPT Efficiency	>99%		
Equipment Protection			
DC reverse polarity protection	Yes		
AC Output Overcurrent Protection	Yes		
AC Output Overvoltage Protection	Yes		
AC Output Short Circuit Protection	Yes		
Thermal Protection	Yes		
Insulation Impedance detection	Yes		

DC Component Monitoring	Yes
Arc fault circuit interrupter (AFCI)	Optional
Anti-islanding protection	Yes
DC Switch	Yes
Residual Current Detection	Yes
Surge Protection Level	TYPE II(DC),TYPE II(AC)
Interface	
Display	LCD+LED
Communication Interface	RS232, RS485, CAN
Monitor Mode	GPRS/WIFI/Bluetooth/4G/LAN (optional)
General Data	
Operating Temperature Range	-40 to +60°C, >45°C Derating
Permissible Ambient Humidity	0-100%
Permissible Altitude	3000m
Noise	≤ 65 dB
Ingress Protection(IP) Rating	IP 65
Inverter Topology	Non-Isolated
Over Voltage Category	OVC II(DC), OVC III(AC)
Cabinet size(W*H*D) [mm]	734W×1091H×344D (Excluding connectors and brackets)
Weight(kg)	161.7
Installation Style	Wall-mounted
Warranty	5 Years/10 Years the Warranty Period Depends the Final Installation Site of Inverter, More Info Please Refer to Warranty Policy
Type of Cooling	Intelligent air cooling
Grid Regulation	IEC 61727,IEC 62116,CEI 0-21,EN 50549,NRS 097,RD 140, UNE 217002,OVE-Richtlinie R25,G99,VDE-AR-N 4105
Safety EMC/Standard	IEC/EN 61000-6-1/2/3/4, IEC/EN 62109-1, IEC/EN 62109-2

* Battery Voltage Range: Please refer to the 'Approved Battery List' for the allowable range of battery module quantity for a set of batteries to ensure the normal operation of the system.

* PV Input Voltage Range: To ensure the system operates at optimal performance, it is recommended to maintain the open-circuit voltage (Voc) of the PV strings below 850V.

10. Appendix I

Definition of RJ45 Ports

No.	Color	BMS1	BMS2	Meter	RS485
1	Orange&White	485_B	485_B	485_B	485_B
2	Orange	485_A	485_A	485_A	485_A
3	Green&White	GND_485	GND_485	GND_COM	GND_485
4	Blue	CAN-H1	CAN-H2	485_B	—
5	Blue&White	CAN-L1	CAN-L2	485_A	—
6	Green	GND_485	GND_485	GND_COM	GND_485
7	Brown&White	485_A	485_A	—	485_A
8	Brown	485_B	485_B	—	485_B



This model of inverter has two types of logger interfaces, DB9 and USB. Please refer to the actual inverter received for the actual interface type.

RS232

No.	RS232
1	
2	TX
3	RX
4	
5	D-GND
6	
7	
8	
9	12Vdc

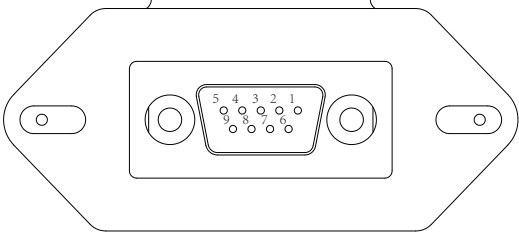

DB9 (RS232)

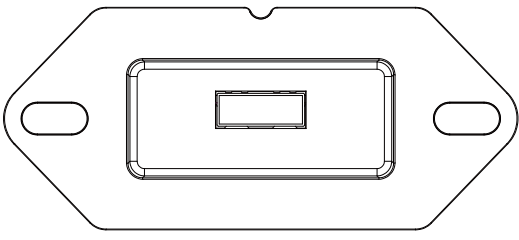

USB

DRM: In Germany, the grid company uses the Ripple Control Receiver to convert the grid dispatching signal and send it as a dry contact signal. The inverter can control power output according to the local preset instructions as shown below.

Definition of RJ45 Port Pin for DRM

No.	DRM
1	DI 1
2	DI 2
3	DI 3
4	DI 4
5	REF
6	GND
7	Reserved
8	Reserved

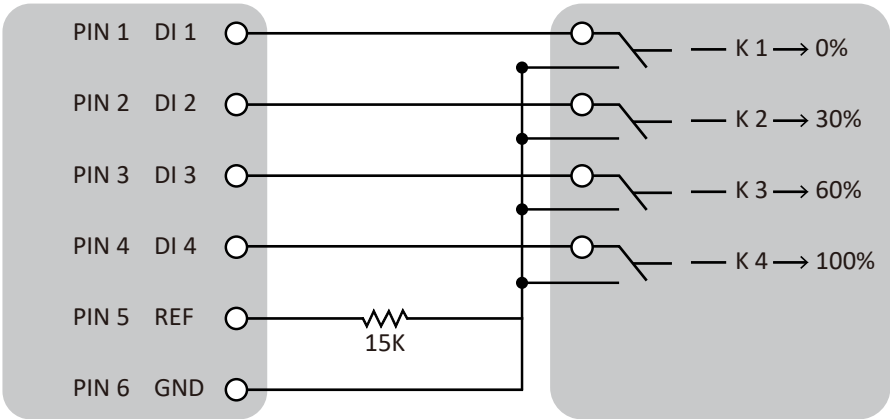
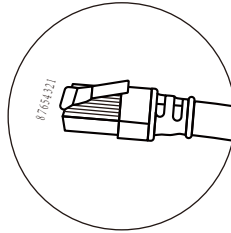

Inverter

RCR

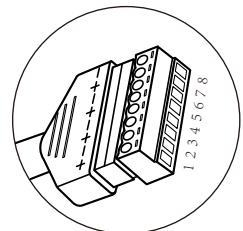
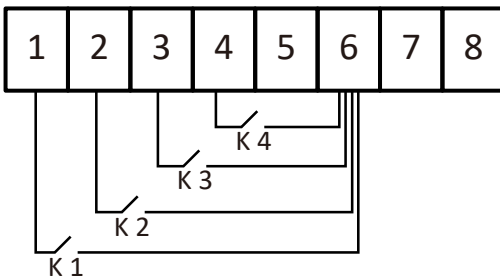

11. Appendix II

1. Split Core Current Transformer (CT) dimension: (mm)
2. Secondary output cable length is 4m.

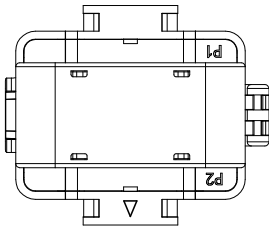
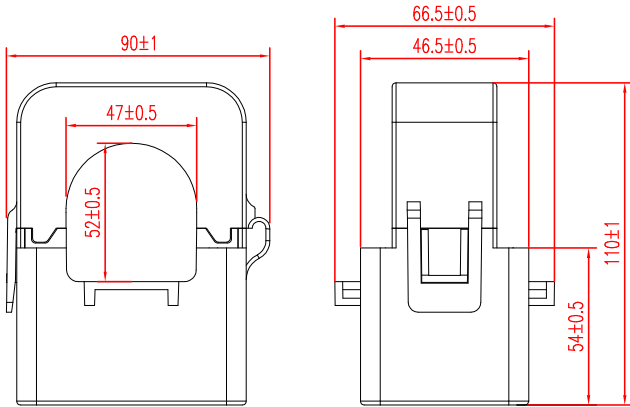

12. Appendix III

When use both the BMS1 port and the BMS2 port of the inverter to communicate with the two different BMS of two sets of battery, there is no need to enable "Parallel bat1&bat2" function.

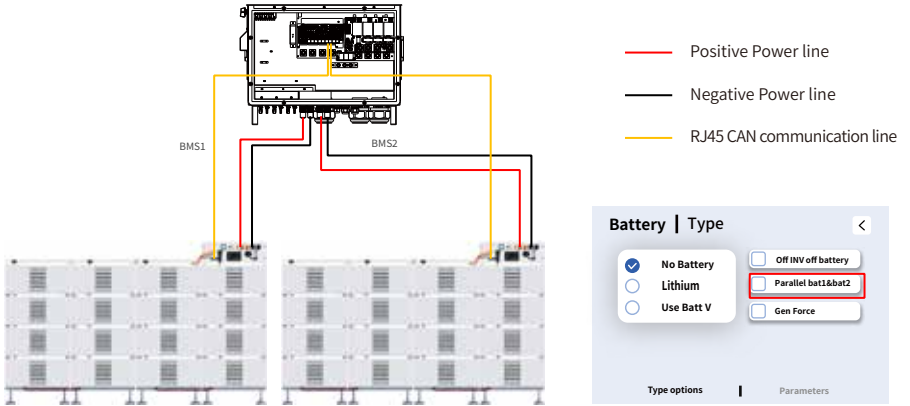

When only use BMS1 port of the inverter to communicate with the BMS of the battery, and both sets of battery power ports are used, it's necessary to enable "Parallel bat1&bat2" function. If the BMS controller of the battery does not have two sets of power cable wiring terminals, additional DC BUS or combiner box needs to be used.

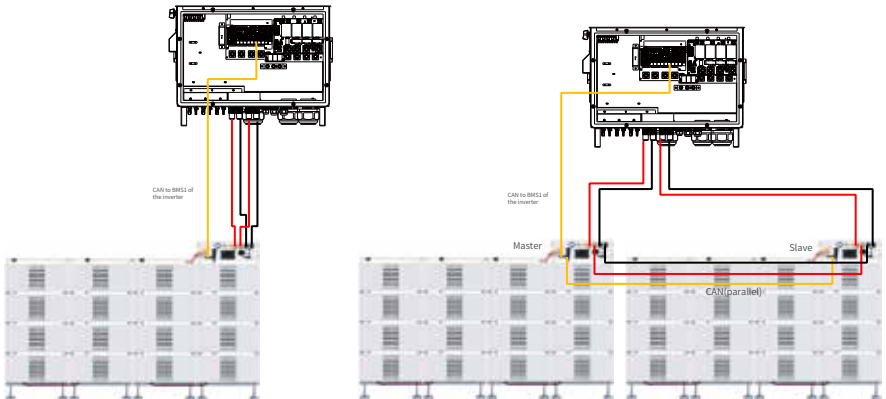

13. EU Declaration of Conformity

within the scope of the EU directives

- Electromagnetic compatibility 2014/30/EU (EMC)
- Radio Equipment Directive (RED) 2014/53/EU
- Restriction of the use of certain hazardous substances 2011/65/EU (RoHS)



NINGBO DEYE INVERTER TECHNOLOGY CO., LTD. confirms herewith that the products described in this document are in compliance with the fundamental requirements and other relevant provisions of the above mentioned directives. The entire EU Declaration of Conformity and certificate can be found at <https://www.deyeinverter.com/download/#hybrid-inverter-5>.

EU Declaration of Conformity

Product: **Hybrid Inverter**

Models: SUN-100K-SG02HP3-EU-GM10, SUN-125K-SG02HP3-EU-GM10, SUN-100K-SG02HP3-EU-GM8

Name and address of the manufacturer: Ningbo Deye Inverter Technology Co., Ltd.
No. 26 South YongJiang Road, Daqi, Beilun, NingBo, China

This declaration of conformity is issued under the sole responsibility of the manufacturer. Also this product is under manufacturer's warranty.

This declaration of conformity is not valid any longer: if the product is modified, supplemented or changed in any other way, as well as in case the product is used or installed improperly.

If the inverter is equipped with a wireless module datalogger in the EU market, the following is complied with:

The object of the declaration described above is in conformity with the relevant Union harmonization legislation:

- Radio Equipment Directive (RED) 2014/53/EU.
- Restriction of the use of certain Hazardous Substances (RoHS) Directive 2011/65/EU and 2015/863/EU



References to the relevant harmonized standards used or references to the other technical specifications in relation to which conformity is declared:

Health and Safety (RED, Article 3.1a)	
EN IEC 62311:2020	●
EN 62109-1:2010	●
EN 62109-2:2011	●
EN 50665:2017	●
EN 50663:2017	●
EN 62479:2010	●
EMC (RED, Article 3.1b)	
EN IEC 61000-6-1:2019	●
EN IEC 61000-6-2:2019	●
EN IEC 61000-6-3:2021	●
EN IEC 61000-6-4:2019	●
EN 301489-1 V2.2.3:2019	●
EN 301489-17 V 3.3.1:2024	●
EN 55011:2016+A1+A11+A2	●
EN 61000-3-3:2013+A1	●
EN 62920:2017+A11+A1	●
EN IEC 61000-3-2:2019	●

EN IEC 61000-3-11:2019	●
EN 61000-3-12:2011+A1:2024	●
Radio Aspects (RED, Article 3.2)	
EN 300328 V2.2.2:2019	●
Cybersecurity (RED, Article 3.3)	
EN 18031-1:2024	●
RoHS	
EN IEC 63000:2018	●

Additional information: CE mark was affixed on the product since 2026.

Nom et Titre / Name and Title:

Bard Dai
Senior Standard and Certification Engineer
宁波德业变频技术有限公司

Au nom de / On behalf of:

NINGBO DEYE INVERTER TECHNOLOGY CO., LTD.

Date / Date (yyyy-mm-dd):

2026-03-26

A / Place:

Ningbo, China

NINGBO DEYE INVERTER TECHNOLOGY CO., LTD.

Add.: No.26 South Yongjiang Road, Daqi, Beilun, NingBo, China.

Tel.: +86 (0) 574 8622 8957

Fax.: +86 (0) 574 8622 8852

E-mail: service@deye.com.cn

Web.: www.deyeinverter.com



30240301005623